



Service instructions

VRF Outdoor Units

Air Flux 5301A | 5301A C

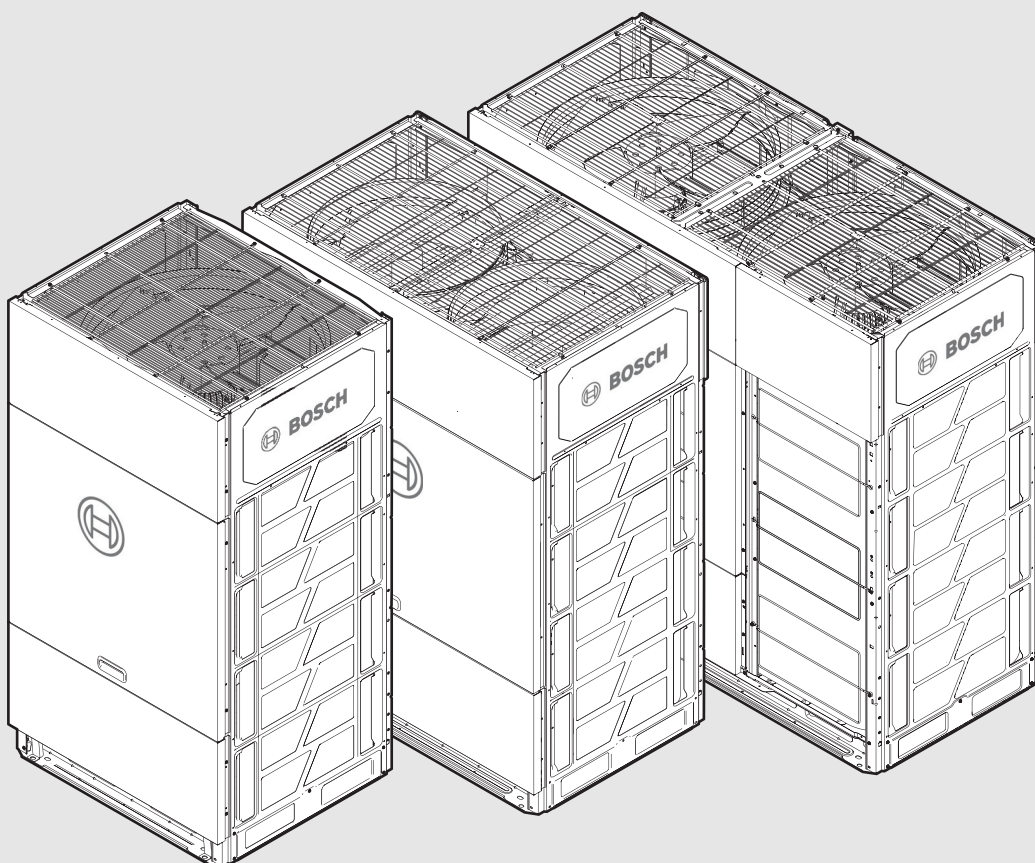

Table of contents

1	Explanation of symbols and safety instructions	4	4.8.2	Vacuum control	35
1.1	Explanation of symbols	4	4.8.3	Auto snow-blowing control	35
1.2	General safety instructions	4	4.8.4	Low noise mode	36
1.2.1	Overview	4	4.8.5	Power limitation mode	37
1.2.2	Refrigerant	4			
1.2.3	Electricity	4			
1.2.4	Preparation of environments with flammable refrigerants	5			
2	General information	6	5	Field settings	38
2.1	Product types	6	5.1	Overview	38
2.2	Nomenclature	6	5.2	Digital display and button settings	38
2.2.1	Outdoor units	6	5.2.1	Digital display output	38
2.2.2	Indoor units	6	5.2.2	Function of buttons SW3 to SW6	38
2.3	Combination ratio	7	5.2.3	Menu mode	38
2.4	Selection procedure	8	5.3	Modes set on main PCB	40
3	Component layout and refrigerant circuits	9	5.3.1	Priority mode setting	40
3.1	Layout of functional components and piping diagrams	9	5.3.2	System test	41
3.2	Description of key components	15	5.3.3	Refrigerant recovery	42
3.3	Refrigerant flow diagrams	16	5.3.4	Refrigerant charge	42
4	Control	22	5.4	System parameter check	43
4.1	General control scheme flowchart	22	6	Electrical components and wiring diagrams	45
4.2	Stop operation	23	6.1	Outdoor unit electric control box layout	45
4.3	Standby control	23	6.2	Outdoor unit main PCB	48
4.4	Start-up control	23	6.2.1	Ports	48
4.4.1	Start-up sequence and frequency control in combination modules	23	6.2.2	Components	49
4.4.2	Compressor start-up delay control	23	6.3	Compressor and fan drive board	51
4.4.3	Start-up control for cooling operation	24	6.3.1	Corresponding table of compressor and fan drive board and outdoor units	51
4.4.4	Start-up control for heating operation	25	6.3.2	Compressor and fan drive board of 35A	51
4.5	Normal operation control	26	6.3.3	Compressor and fan drive board of 50A	52
4.5.1	Component control during normal operation	26	6.3.4	Compressor and fan drive board of 75A	53
4.5.2	Compressor control	26	6.3.5	Compressor and fan drive board ports	54
4.5.3	Rotation of the compressors	27	6.3.6	Compressor and fan drive board installation guide	56
4.5.4	Heat exchanger control	27	6.3.7	Fan drive board ports	57
4.5.5	Electronic expansion valve control	27	6.4	Electrical wiring	58
4.5.6	EEVC control	27	7	Diagnosis and troubleshooting	59
4.5.7	Outdoor fan control	28	7.1	Error codes	59
4.6	Protection control	29	7.1.1	Outdoor unit error codes	59
4.6.1	High pressure protection control	29	7.1.2	Installation and debugging error codes	60
4.6.2	Low pressure protection control	29	7.1.3	Compressor driver error codes	61
4.6.3	Discharge temperature protection control	30	7.1.4	Fan motor error codes	61
4.6.4	Over-current protection control	30	7.1.5	Status codes	61
4.6.5	Ambient temperature out of range protection control	31	7.2	Troubleshooting	62
4.6.6	Inverter module temperature protection control	31	7.2.1	Warning	62
4.6.7	Wet compression protection control	32	7.2.2	Error in main control	62
4.6.8	High pressure ratio protection control	32	7.2.3	A01: Emergency shut-down of outdoor units	62
4.7	Special control	33	7.2.4	xA61: No.x of slave units error	63
4.7.1	Oil return operation	33	7.2.5	AAx: Inverter driver board X does not match the main control board	64
4.7.2	Defrosting operation	34	7.2.6	xb53: No.x Recirculation fan error	65
4.8	Other controls	35	7.2.7	bA1: SuperLink cannot open or close indoor unit's Electronic Expansion Valve	66
4.8.1	Overload control	35	7.2.8	U38: Outdoor unit has no address	67
			7.2.9	C13: The address of the outdoor unit is repeated	68
			7.2.10	C21: Communication error between indoor and outdoor unit	69
			7.2.11	C26: Abnormal reduction in the number of indoor units	71
			7.2.12	C28: Abnormal increase in the number of indoor units	73

1 Explanation of symbols and safety instructions

1.1 Explanation of symbols

Warnings

In warnings, signal words at the beginning of a warning are used to indicate the type and seriousness of the ensuing risk if measures for minimising danger are not taken.

The following signal words are defined and can be used in this document:

DANGER

DANGER indicates that severe or life-threatening personal injury will occur.

WARNING

WARNING indicates that severe to life-threatening personal injury may occur.

CAUTION

CAUTION indicates that minor to medium personal injury may occur.

NOTICE

NOTICE indicates that material damage may occur.

Important information



The info symbol indicates important information where there is no risk to people or property.

1.2 General safety instructions

1.2.1 Overview

This service manual is intended for service engineers. All instructions must be observed. Failure to comply with instructions may result in material damage and personal injury, including danger to life

- ▶ Read the installation manuals (outdoor unit, indoor unit, etc) prior to maintenance.
- ▶ Observe the safety instructions and warnings.
- ▶ Follow national and regional regulations, technical regulations and guidelines.

Warning

- ▶ Do not touch the refrigerant piping, water piping or internal parts during operations or when the operation has just been completed. This is because the temperature may be too high or too low. Let them recover to the normal temperature first. Wear protective gloves if you must come in contact with these.
- ▶ Do not touch any refrigerant that has accidentally leaked.

Caution

- ▶ Please wear the appropriate personal protective tools during installation, maintenance or repair of the system (protective gloves, safety glasses, etc.).
- ▶ Do not touch the air inlet or aluminium fin of the unit.

Notice

- ▶ Improper installation or connection of equipment and accessories may cause electric shocks, short circuits, leaks, fires, or other damage to the equipment. Use only accessories, equipment and spare parts made or approved by the manufacturer.

- ▶ Do not place any object or equipment on top of the unit.
- ▶ Do not sit, climb, or stand on the unit.

1.2.2 Refrigerant

Warning

- ▶ Take appropriate precautions to prevent refrigerant leakage. If the refrigerant gas leaks, ventilate the area immediately. Possible risk: An excessively high concentration of refrigerant in an enclosed area can lead to anoxia (oxygen deficiency). The refrigerant gas may produce a toxic gas if it comes in contact with fire.
- ▶ Refrigerant must be recovered. Do not release it to the environment. Use the vacuum pump to draw the refrigerant out from the unit.

Notice

- ▶ Do not charge refrigerant before the wiring layout is completed.
- ▶ Only charge the refrigerant after the leak tests and vacuum drying have been completed.
- ▶ When charging the system with refrigerant, do not exceed the allowable charge.

1.2.3 Electricity

Notice

- ▶ All electrical works and repairs must be done by a certified installer or electrician.

Warning

- ▶ Make sure you switch off the power of the unit before you open the electric control box, and access any circuit wiring or components inside. At the same time, this prevents the unit from being accidentally powered up during installation or maintenance work.
- ▶ Once you open the cover of the electric control box, do not let any liquid spill into the box, and do not touch the components in the box with wet hands.
- ▶ Cut off power supply more than 5 minutes prior to access the electrical parts. Measure the voltage of the main circuit capacitor or electrical component terminals to make sure the voltage is less than 36 V before you touch any circuit component. Refer to the connections and wiring on the nameplate for the master circuit terminals and connections.
- ▶ Make sure the wiring ends are not subjected to any external force. Do not pull or squeeze the cables and wires. At the same time, make sure the wiring ends are not in contact with the piping or sharp edges of the sheet metal.
- ▶ Make sure all terminals of the components are firmly connected before you close the cover of the electric control box. Before you power on and start the unit, check that the cover of the electric control box is seated correctly and secured with screws.



The appliance shall be installed in accordance with national wiring regulations.



This unit must be connected to the main power supply by means of a switch with a contact separation of at least 3 mm.



Before maintenance, power off the unit.

1.2.4 Preparation of environments with flammable refrigerants

Checks to the area

Prior to beginning work on systems containing flammable refrigerants, safety checks are necessary to ensure that the risk of ignition is minimized.

Work procedure

Work shall be undertaken under a controlled procedure so as to minimise the risk of a flammable gas or vapour being present while the work is being performed.

General work area

All maintenance staff and others working in the local area shall be instructed on the nature of work being carried out. Work in confined spaces shall be avoided.

Checking for presence of refrigerant

The area shall be checked with an appropriate refrigerant detector prior to and during work, to ensure the technician is aware of potentially toxic or flammable atmospheres.

- ▶ Ensure that the leak detection equipment being used is suitable for use with all applicable refrigerants, i.e. non-sparking, adequately sealed or intrinsically safe.

Presence of fire extinguisher

If any hot work is to be conducted on the refrigerating equipment or any associated parts, appropriate fire extinguishing equipment shall be available to hand.

- ▶ Have a dry powder or CO₂ fire extinguisher adjacent to the charging area.

No ignition sources

- No person carrying out work in relation to a refrigerating system which involves exposing any pipe work shall use any sources of ignition in such a manner that it may lead to the risk of fire or explosion.
- All possible ignition sources, including cigarette smoking, should be kept sufficiently far away from the site of installation, repairing, removing and disposal, during which refrigerant can possibly be released to the surrounding space.
- Prior to work taking place, the area around the equipment is to be surveyed to make sure that there are no flammable hazards or ignition risks. "No Smoking" signs shall be displayed.

Ventilated area

- A degree of ventilation shall continue during the period that the work is carried out.
- The ventilation should safely disperse any released refrigerant and preferably expel it externally into the atmosphere

Checks to electrical devices

- Repair and maintenance to electrical components shall include initial safety checks and component inspection procedures.
- If a fault exists that could compromise safety, then no electrical supply shall be connected to the circuit until it is satisfactorily dealt with. If the fault cannot be corrected immediately but it is necessary to continue operation, an adequate temporary solution shall be used. This shall be reported to the owner of the equipment so all parties are advised.
- Initial safety checks shall include:
 - that capacitors are discharged: this shall be done in a safe manner to avoid possibility of sparking;
 - that no live electrical components and wiring are exposed while charging, recovering or purging the system;
 - that there is continuity of earth bonding.

During repairs to sealed components, all electrical supplies shall be disconnected from the equipment being worked upon prior to any removal of sealed covers, etc.

If it is absolutely necessary to have an electrical supply to equipment during servicing, then a permanently operating form of leak detection shall be located at the most critical point to warn of a potentially hazardous situation.



Particular attention shall be paid to the following to ensure that by working on electrical components the casing is not altered in such a way that the level of protection is affected.

This shall include damage to cables, excessive number of connections, terminals not made to original specification, damage to seals, incorrect fitting of glands, etc.

- ▶ Ensure that seals or sealing materials have not degraded to the point that they no longer serve the purpose of preventing the ingress of flammable atmospheres.

Repair to intrinsically safe components

- ▶ Do not apply any permanent inductive or capacitance loads to the circuit without ensuring that this will not exceed the permissible voltage and current permitted for the equipment in use.
- ▶ The test apparatus shall be at the correct rating. Intrinsically safe components are the only types that can be worked on while live in the presence of a flammable atmosphere.

NOTICE

Risk of refrigerant ignition and leakage

Using parts not specified by manufacturer may result in the ignition of refrigerant in the atmosphere from a leak.

- ▶ Replace components only with parts specified by the manufacturer.

2 General information

2.1 Product types

Three-phase outdoor units

Type name	KW	HP
AF5301A A C 25-3	25	8
AF5301A A C 28-3	28	10
AF5301A A C 33-3	33	12
AF5301A A C 40-3	40	14
AF5301A A C 45-3	45	16
AF5301A A C 50-3	50	18
AF5301A A C 56-3	56	20
AF5301A A C 62-3	62	22
AF5301A A C 67-3	67	24
AF5301A A C 73-3	73	26
AF5301A A C 79-3	79	28
AF5301A A C 85-3	85	30
AF5301A A C 90-3	90	32

Table 1 3-phase units

2.2 Nomenclature

2.2.1 Outdoor units

Category name	Value level	Group name	Output/generation	Power supply
AF	5301	A	25	-3

Table 2 Product type

Component	Value	Description
Category name	AF	Air Flux; variable refrigerant flow air conditioning unit (VRF)
Value level	5301	VRF unit with medium efficiency, 2 pipes, ambient temperature up to °C
Group name	A	Air based system
	C	
Output/generation	25	25 kW heat output
Power supply	-3	Three phases

Table 3 Product type description

2.2.2 Indoor units

Indicator	Unit type	Output/generation	Additional features
AF2	4CR	45	E

Table 4 Product type

Component	Value	Description
Indicator	AF2	Air Flux; variable refrigerant flow air conditioning unit (VRF)

Component	Value	Description
Unit type	4CC	Cassette series: 4 way compact
	4C	Cassette series: 4 way
	4CR	Cassette series: Round flow
	4CS	Cassette series: 4 way Silent
	1C	Cassette series: 1 way
	DL	Duct series: Low ESP
	DM	Duct series: Medium ESP
	DH	Duct series: High ESP
	DMS	Duct series: Medium ESP Silent
	F	Floor series: Without cabinet
	FC	Floor series: With cabinet
	CF	Floor series: Ceiling-floor
	W	Wall series: Basic
	Output/generation	45
Additional features	E	Electrical heater
	P	Pump integrated

Table 5 Product type description

2.3 Combination ratio



There is no outdoor unit combination possible for AF5301 A and AF5301A C.

$$CR = \frac{I_{IDU}}{I_{ODU}}$$

CR Combination ratio
 I_{IDU} Sum of capacity indexes of the indoor units
 I_{ODU} Capacity index of the outdoor units

Type	Minimum combination ratio	Maximum combination ration		
		Standard indoor units only	Fresh air processing units only	Fresh air processing units and standard indoor units together
AF5301A	50%	130% or 200%	100%	100%
AF5301A C	50%	200% (single outdoor unit) 130% (combined outdoor unit)	100%	100%

Table 6

The following information is only applicable to 200% combination rate:

- Ensure that all connected indoor units feature a copper tube heat exchanger with a ø5mm size. This requirement is in place to prevent potential reliability and performance issues associated with oversized indoor unit exchangers.
- The piping distance between the farthest indoor unit and the initial indoor branch joint should not exceed 40m.
- Customization options are available for combination ratios exceeding 130%.
- When fresh air processing units are installed alongside standard indoor units, the total capacity of the fresh air processing units must not exceed 30% of the total capacity of the outdoor units and the total combination ratio must not exceed 100%.

Outdoor unit capacity		Sum of capacity indexes of connected indoor units (standard indoor units only)	Maximum number of connected indoor units
KW	Capacity index		
25	252	162 - 327.6	13
28	280	140 - 364	16
33	335	167.5 - 435.5	19
40	400	200 - 520	23
45	450	225 - 585	26
50	500	250 - 650	29
56	560	280 - 728	33
62	615	307.5 - 799.5	36
67	670	335 - 871	39
73	730	365 - 949	43
79	785	392.5 - 1020.5	46
85	850	425 - 1105	50
90	900	450 - 1170	53

Table 7 AF5301 A and AF5301 A C series

2.4 Selection procedure

1. Establish design conditions.
 - Design temperature and humidity (indoor and outdoor)
 - Required heat load of each room
 - System peak load
 - Piping length, level differences
 - Indoor unit specifications (type and quantity)
 - Room area

If $M_c \leq 12\text{kg}$, determine applicable standards (EN60335-2-40 and IEC60335-2-40).

If $M_c \geq 12\text{kg}$, adjust the piping length and reduce the refrigerant charge.



If the indoor design temperature falls between two temperatures listed in the indoor unit's capacity table, calculate the corrected capacity by interpolation.

If the indoor unit selection is to be based on total heat load and sensible heat load, select indoor units which satisfy not only the total heat load requirements of each room but also the sensible heat load requirements of each room. As with total heat capacity, the sensible heat capacity of indoor units should be corrected for indoor temperature, interpolating where necessary.

For the indoor unit capacity tables, refer to the indoor unit technical manuals.

1. Select indoor units.
 - Decide indoor unit safety factor
 - Correct indoor unit capacity for indoor air temperature
 - Apply the formula $WB1 \geq \text{Required heat load} \times \text{Indoor unit safety factor}$
2. Select outdoor unit.
 - Determine required total heat load on the outdoor unit
 - Use the sum of the peak load of each room and the system peak load
 - Provisionally select outdoor unit capacity based on combination ratio limitations
 - Confirm that the number of indoor units connected to the outdoor unit is within limitation
 - Correct cooling and heating capacities of the outdoor unit for Outdoor air temperature, Indoor air temperature WB, Combination ratio, Piping length, level difference, Piping heat loss, Frost accumulation (for heating capacity only)

If corrected outdoor unit capacity \geq required total heat load on outdoor unit, proceed to **Condition 1**.

If corrected outdoor unit capacity \leq required total heat load on outdoor unit, repeat the selection of the outdoor unit capacity based on combination ratio limitations.

Condition 1

- ▶ Calculate the refrigerant charge limit for each room M_{max}
If $M_c \leq M_{\text{max}}$, the room selection is complete.

3 Component layout and refrigerant circuits

3.1 Layout of functional components and piping diagrams

AF5301A | A C 25-3 AF5301A | A C 45-3 outdoor units

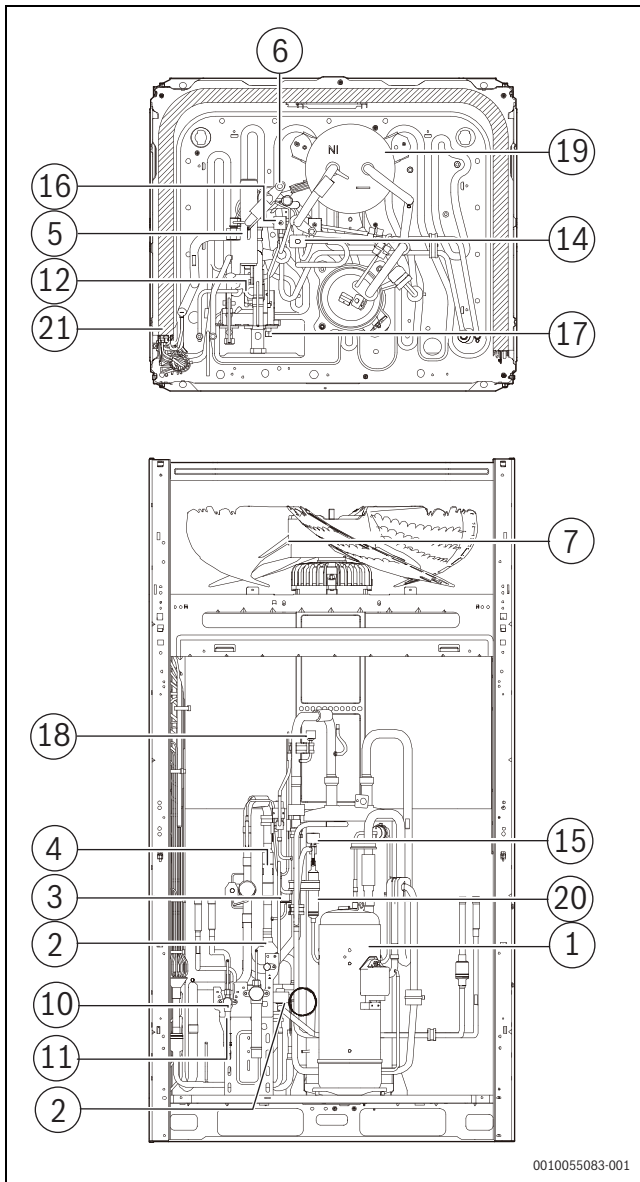

Fig. 1 Component layout

,AF5301A | A C 50-3 - AF5301A | A C 67-3 outdoor units

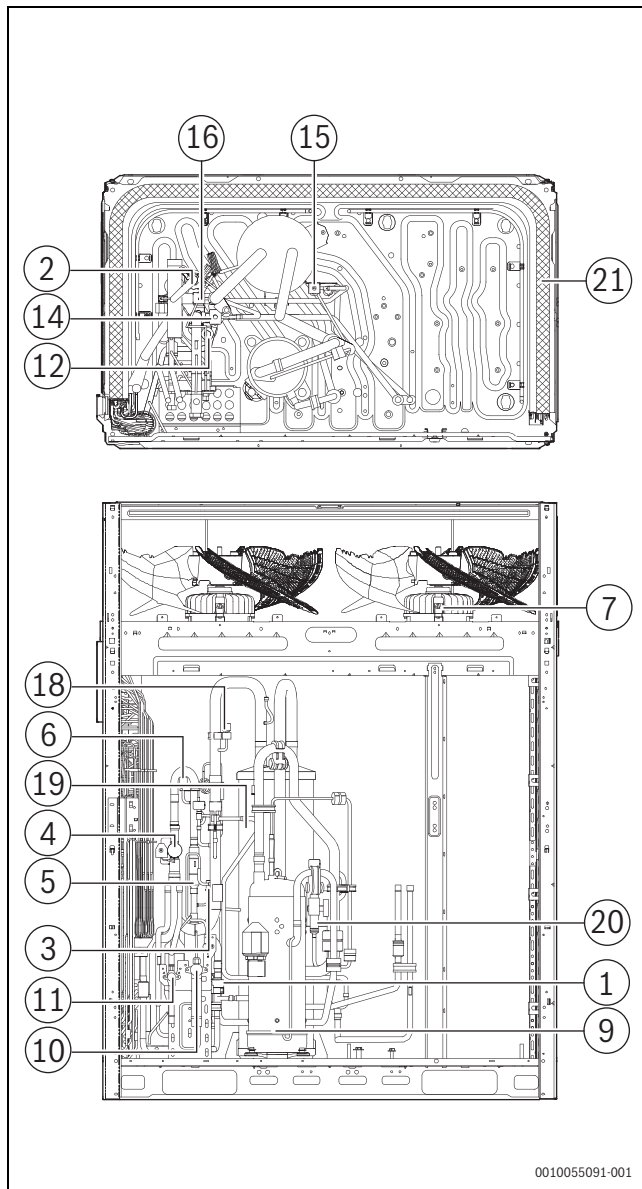
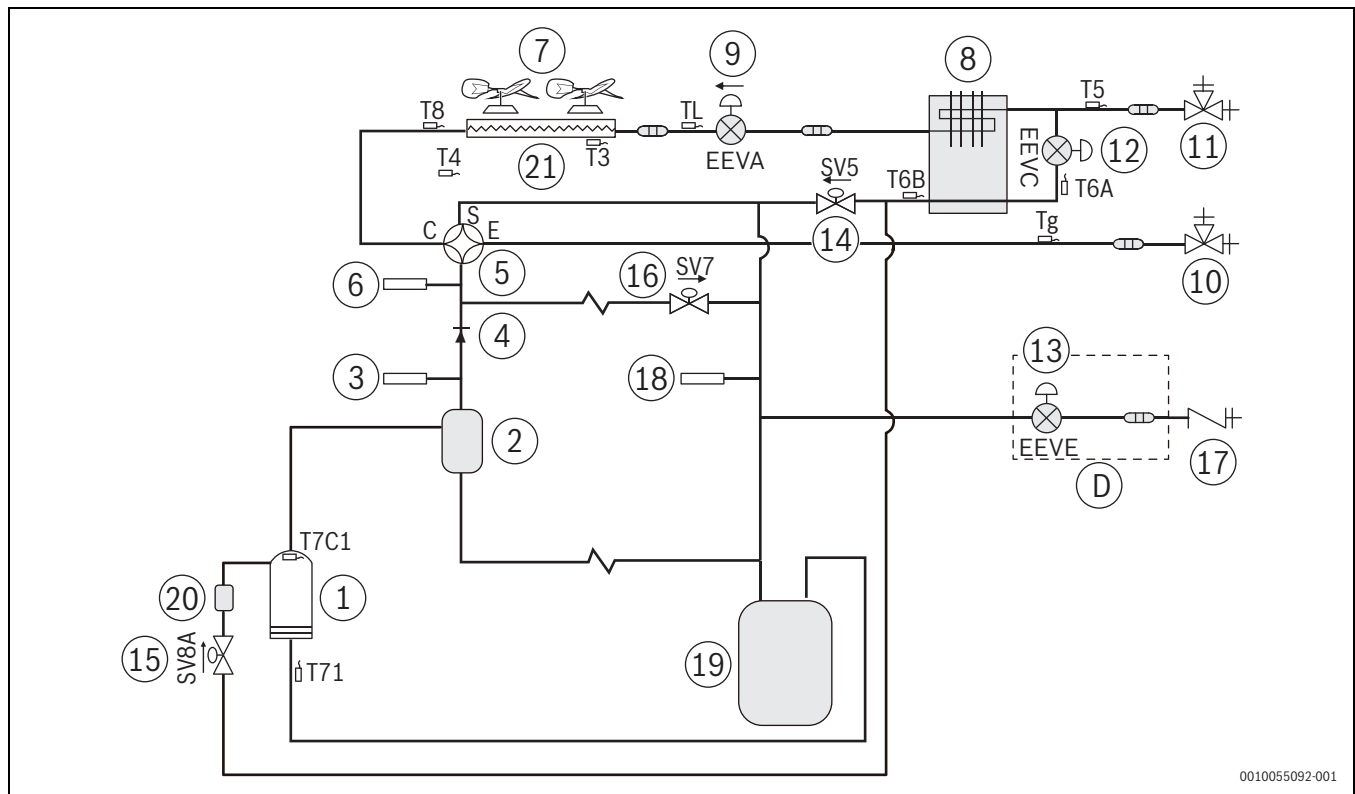

Fig. 3 Component layout



0010055092-001

Fig. 4 Refrigerant circuit

Legend Figure 3 and 4:

- [1] Compressor
 - [2] Oil separator
 - [3] High pressure switch
 - [4] Check valve
 - [5] Four-way valve (ST1)
 - [6] High pressure sensor
 - [7] Fan
 - [8] Micro-channel heat exchanger
 - [9] Electronic expansion valve (EEVA)
 - [10] Stop valve (gas side)
 - [11] Stop valve (liquid side)
 - [12] Electronic expansion valve (EEVC)
 - [13] Electronic expansion valve (optional EEVE)
 - [14] Injection bypass solenoid valve (SV5)
 - [15] Compressor vapour injection valve (SV8A)
 - [16] Hot gas bypass solenoid valve (SV7)
 - [17] Charge port
 - [18] Low pressure sensor
 - [19] Gas-liquid separator
 - [20] Muffler
 - [21] Heat exchanger
-
- T3 Heat exchanger temperature sensor
 - T4 Outdoor air temperature sensor
 - T5 Liquid pipe temperature sensor
 - T6A Injection liquid temperature sensor
 - T6B Sub-cooling gas temperature sensor
 - T71 Suction temperature sensor
 - T8 Condenser inlet temperature sensor
 - Tg Gas pipe temperature sensor
 - TL Condenser outlet temperature sensor
 - T7C1 Compressor discharge temperature sensor
 - Tb Electric control box chamber temperature sensor

AF5301A | A C 73-3 AF5301A | A C 90-3 outdoor units

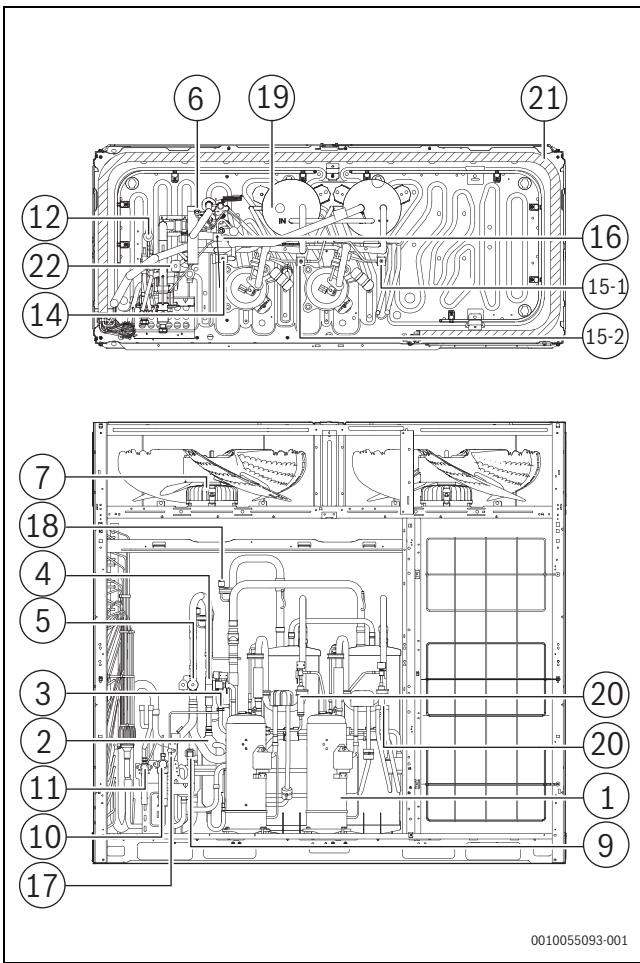

Fig. 5 Component layout

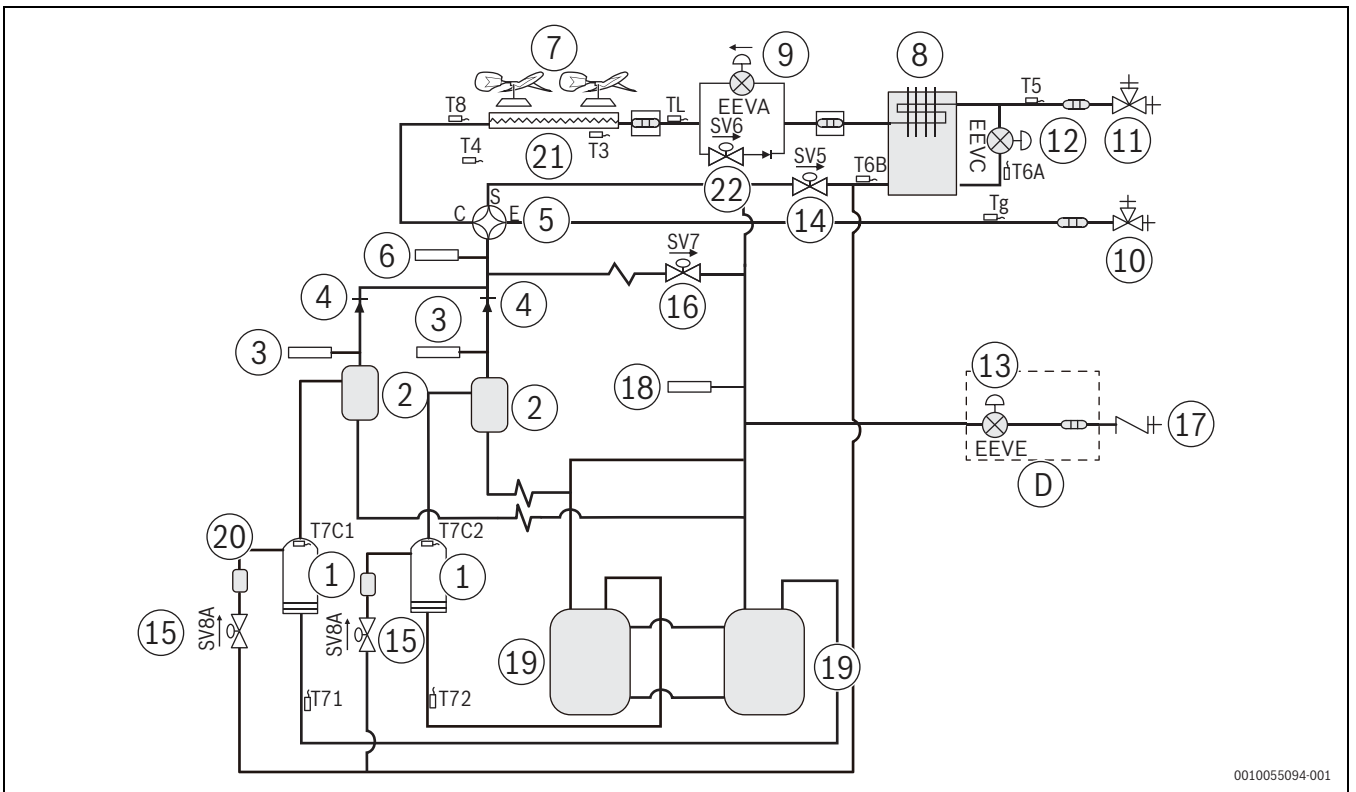

Fig. 6 Refrigerant circuit

Legend Figure 5 and 6:

[1]	Compressor
[2]	Oil separator
[3]	High pressure switch
[4]	Check valve
[5]	Four-way valve (ST1)
[6]	High pressure sensor
[7]	Fan
[8]	Micro-channel heat exchanger
[9]	Electronic expansion valve (EEVA)
[10]	Stop valve (gas side)
[11]	Stop valve (liquid side)
[12]	Electronic expansion valve (EEVC)
[13]	Electronic expansion valve (optional EEVE)
[14]	Injection bypass solenoid valve (SV5)
[15]	Compressor vapour injection valves (SV8B [15-1] and SV8A [15-2])
[16]	Hot gas bypass solenoid valve (SV7)
[17]	Charge port
[18]	Low pressure sensor
[19]	Gas-liquid separator
[20]	Muffler
[21]	Heat exchanger
T3	Heat exchanger temperature sensor
T4	Outdoor air temperature sensor
T5	Liquid pipe temperature sensor
T6A	Injection liquid temperature sensor
T6B	Sub-cooling gas temperature sensor
T71/T72	Suction temperature sensor
T8	Condenser inlet temperature sensor
Tg	Gas pipe temperature sensor
TL	Condenser outlet temperature sensor
T7C1/T7C2	Compressor discharge temperature sensor
Tb	Electric control box chamber temperature sensor

3.2 Description of key components

Key components	Description
Oil separator	Separates oil from gas refrigerant pumped out of the compressor and quickly returns it to the compressor. Separation efficiency is up to 99%.
Gas-liquid separator	Stores liquid refrigerant and oil to protect compressor from liquid hammering.
Electronic expansion valve (EEVA/EEVB)	Controls refrigerant flow and reduces refrigerant pressure.
Four-way valve	Controls refrigerant flow direction. Closed in cooling mode and open in heating mode. When closed, the heat exchanger functions as a condenser; when open, the heat exchanger functions as an evaporator.
Micro-channel heat exchanger	In Cooling mode, the micro-channel heat exchanger enhances the super-cooling degree, allowing the super-cooled refrigerant to achieve more efficient heat exchange in indoor units. During Heating mode, redirecting the refrigerant from the micro-channel heat exchanger to the compressor increases the refrigerant volume, thereby improving heating capacity in low ambient temperatures. The refrigerant volume within the micro-channel heat exchanger is regulated based on temperature differences between the inlet and outlet of the micro-channel heat exchanger or the difference between discharge temperature and the target discharge temperature.
Solenoid valve SV5	Regulates the flow of refrigerant from the micro-channel heat exchanger to the gas-liquid separator.
Solenoid valve SV6	Facilitates refrigerant bypass for the expansion valves. It opens during Cooling mode when the discharge temperature exceeds the limit and remains closed during Heating mode and Standby.
Solenoid valve SV7	Manages bypass pressure during the start-up stage, controls capacity during low-load conditions, prevents high-pressure rise, and offers discharge superheat protection.
Solenoid valve SV8A/B	Allows refrigerant from the micro-channel heat exchanger to be injected directly into the compressor. The solenoid valve SV8A/B opens when compressor starts up and closes when the compressor stops.
High and low pressure switches	Regulates the system pressure. When the system pressure rises above the upper limit or falls below the lower limit, the high or low pressure switches turn off, stopping the compressor. After 10 minutes, the compressor restarts.
High and low pressure sensors	Used to detect the high or low pressure of the system.

Table 8

3.3 Refrigerant flow diagrams

AF5301A | A C 25-3 to AF5301A | A C 45-3

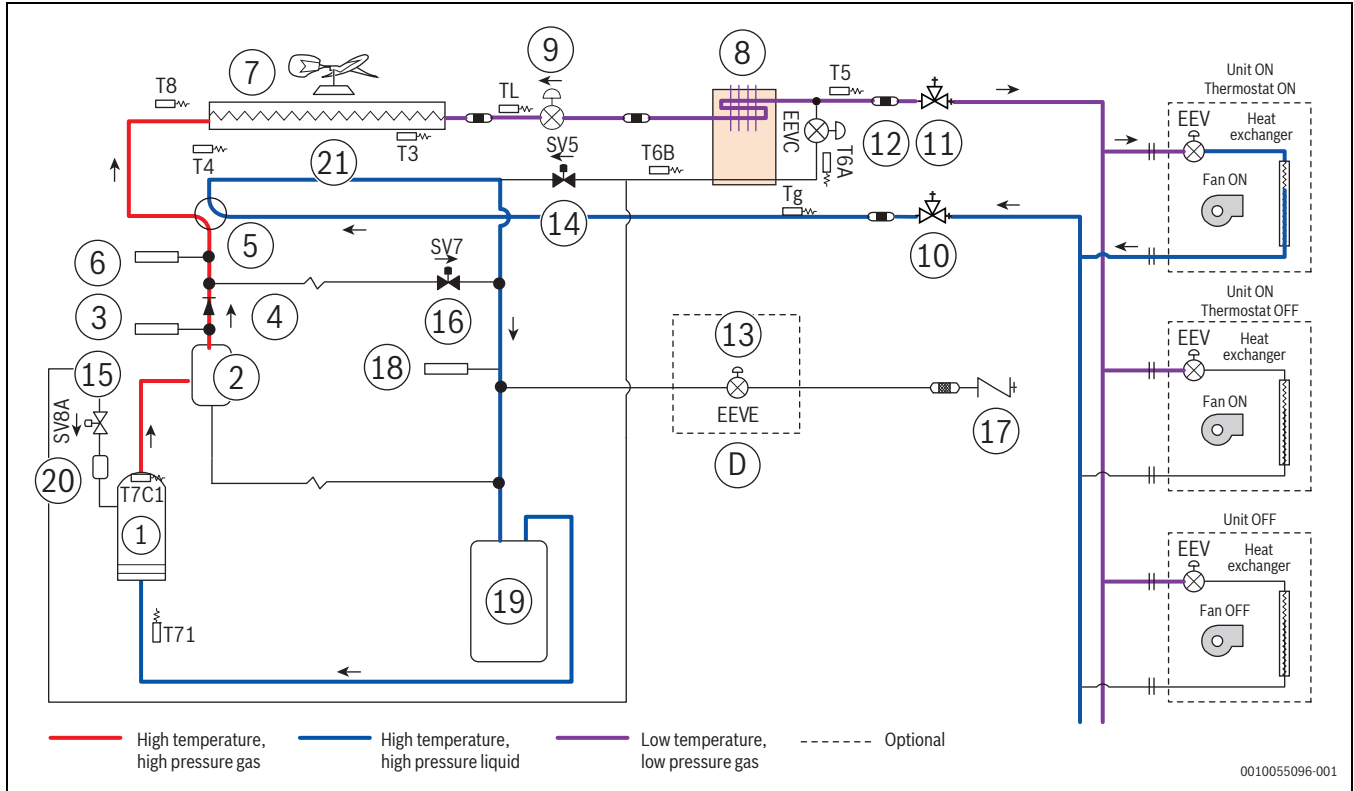

Fig. 7 Cooling operation

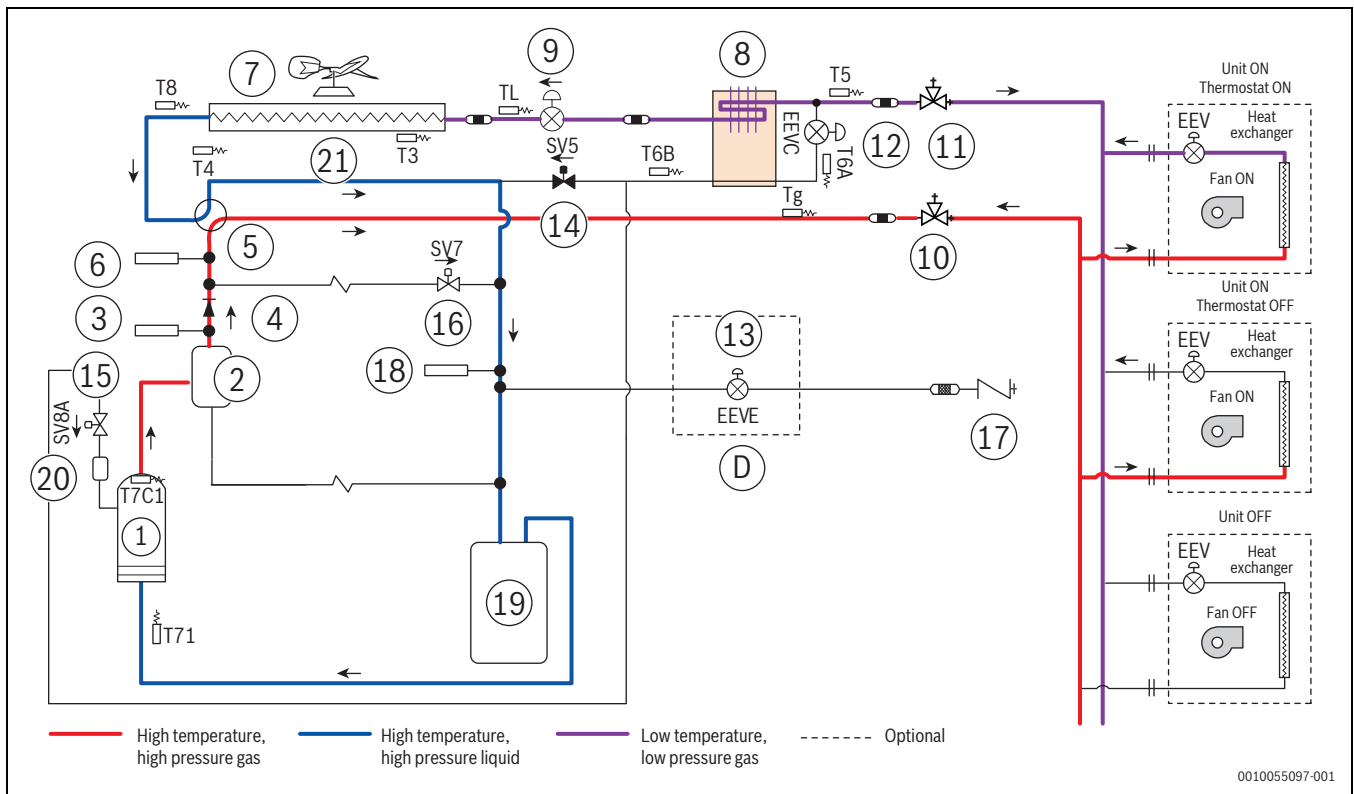

Fig. 8 Heating operation

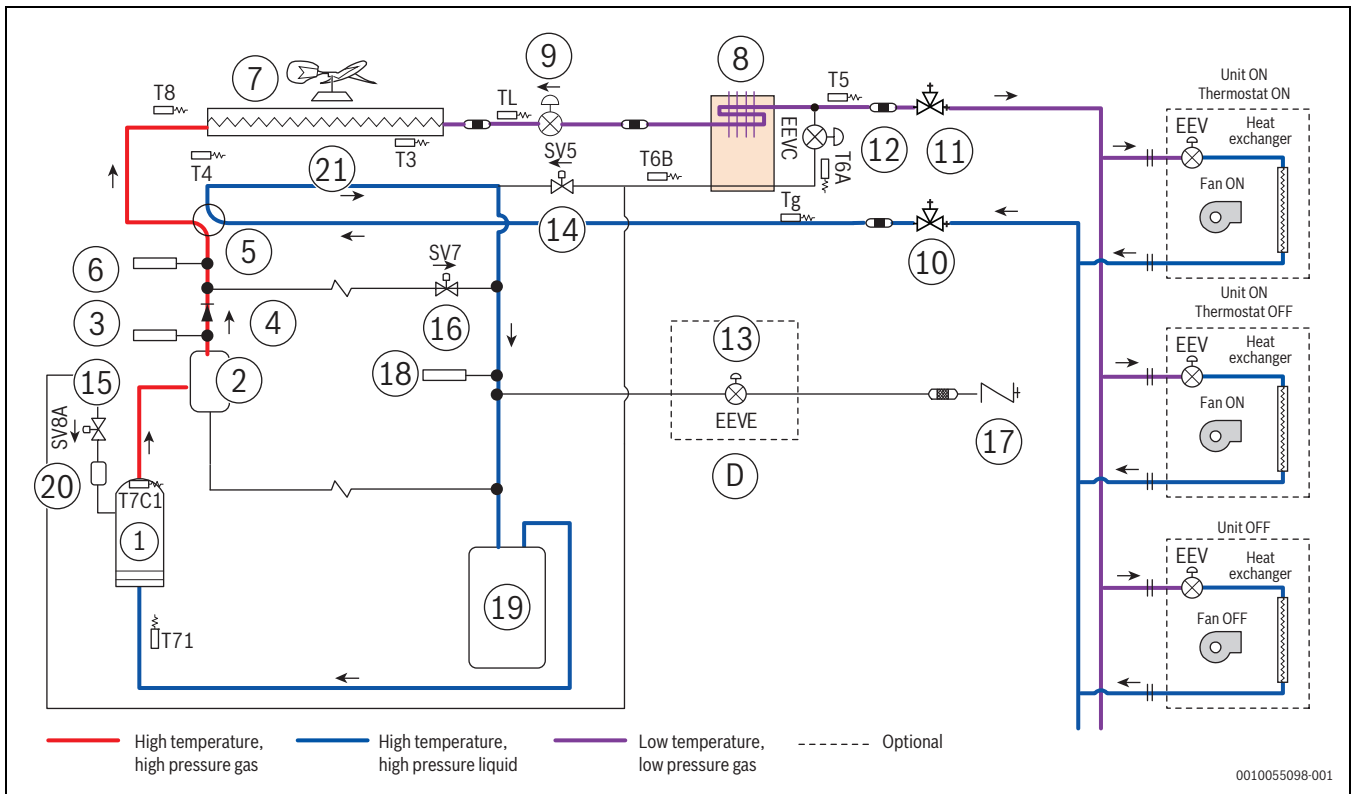

Fig. 9 Oil return operation in cooling mode

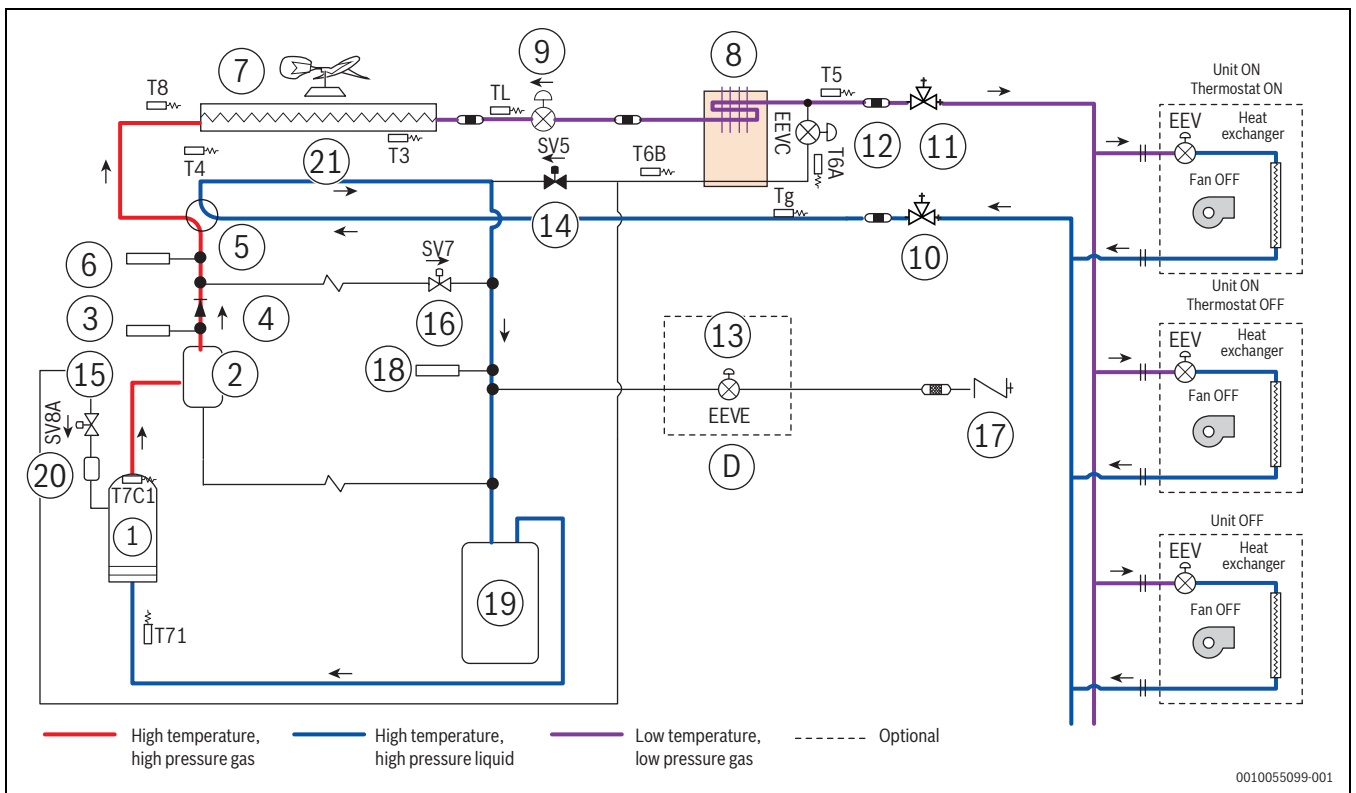

Fig. 10 Oil return operation in heating mode and defrosting operation (4-way valve, change direction)

AF5301A | A C 50-3 to AF5301A | A C 67-3

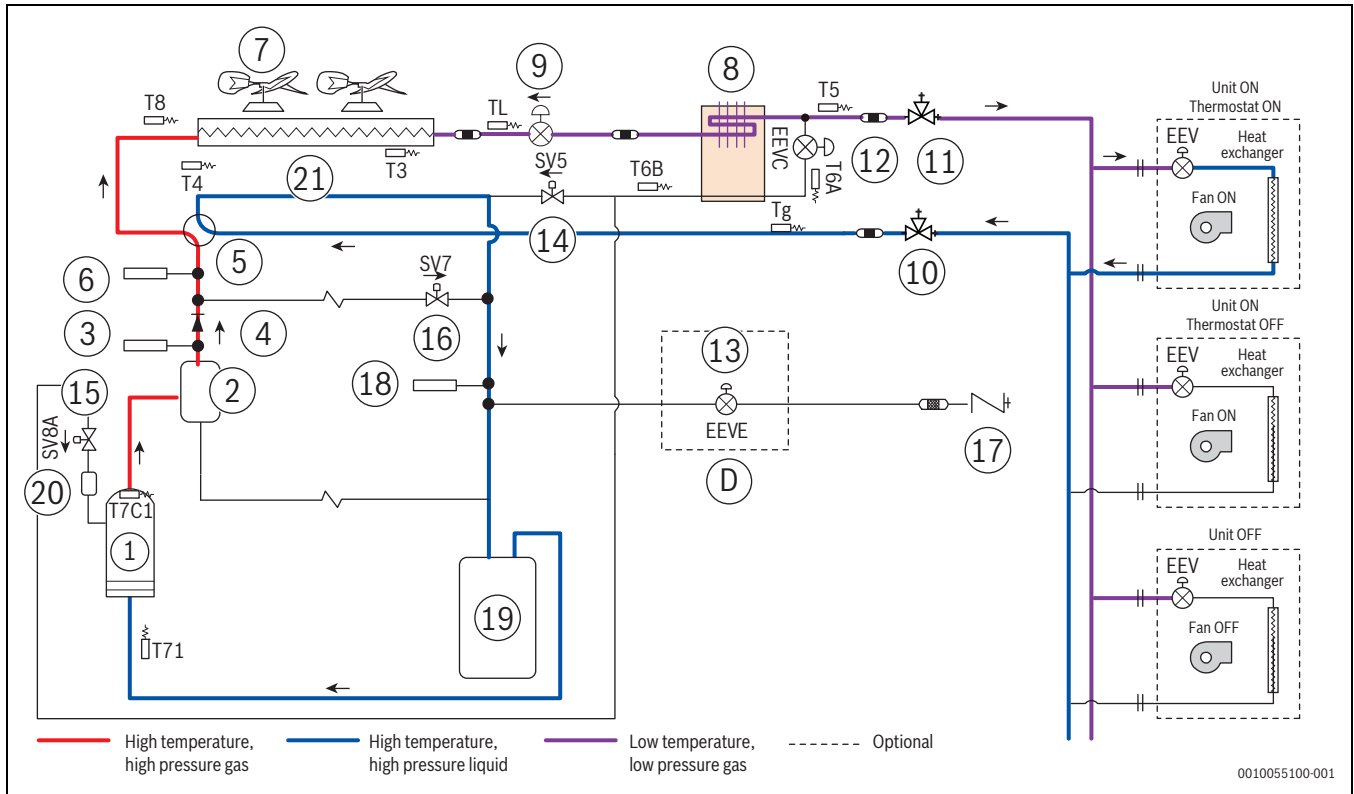

Fig. 11 Cooling operation

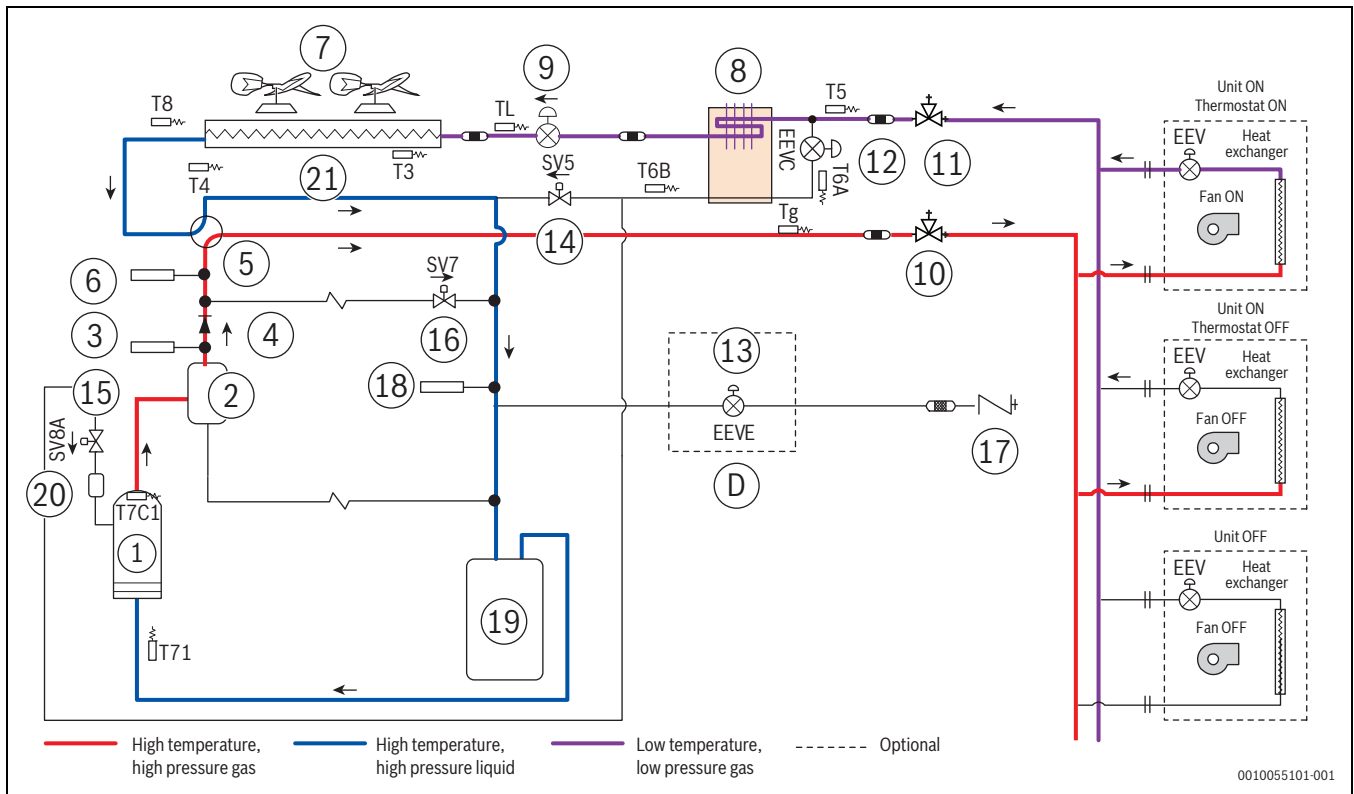

Fig. 12 Heating operation

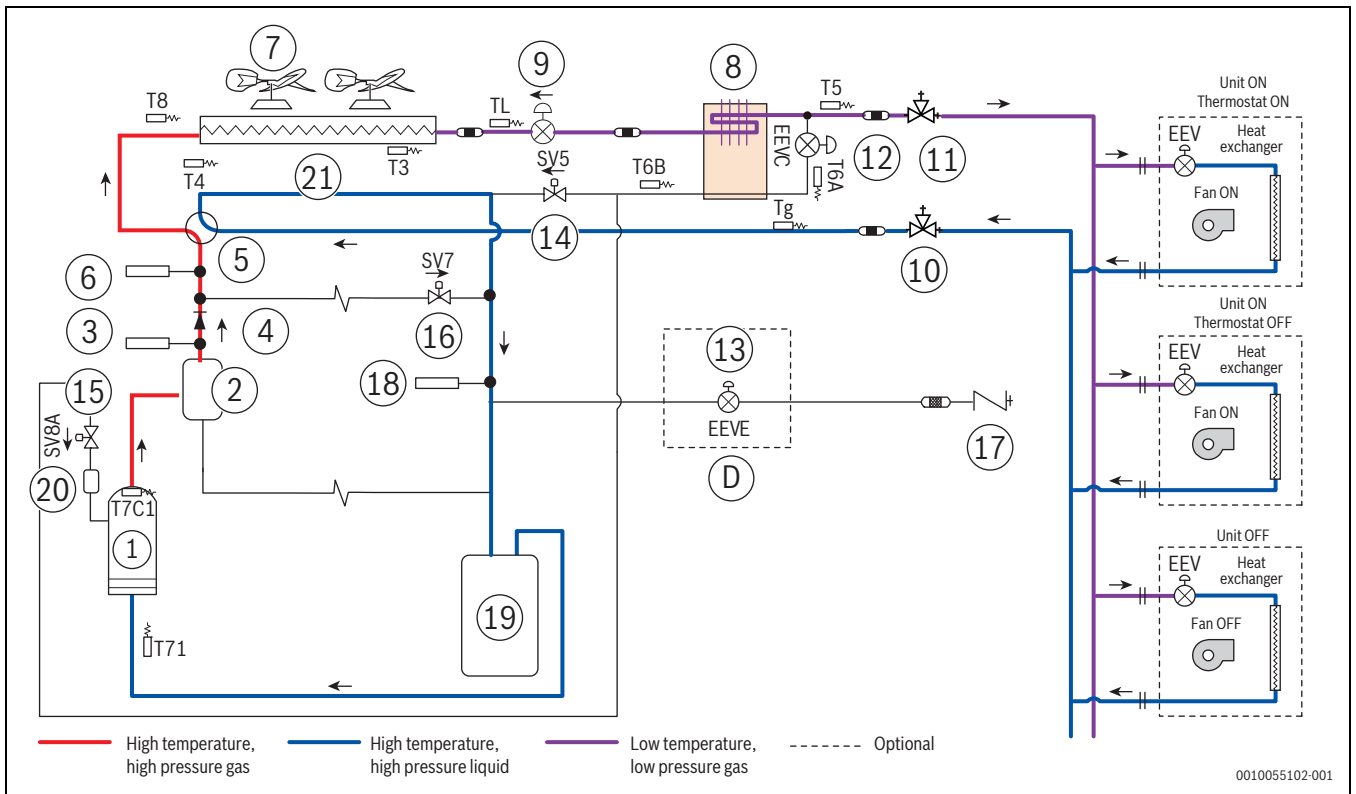

Fig. 13 Oil return operation in cooling mode

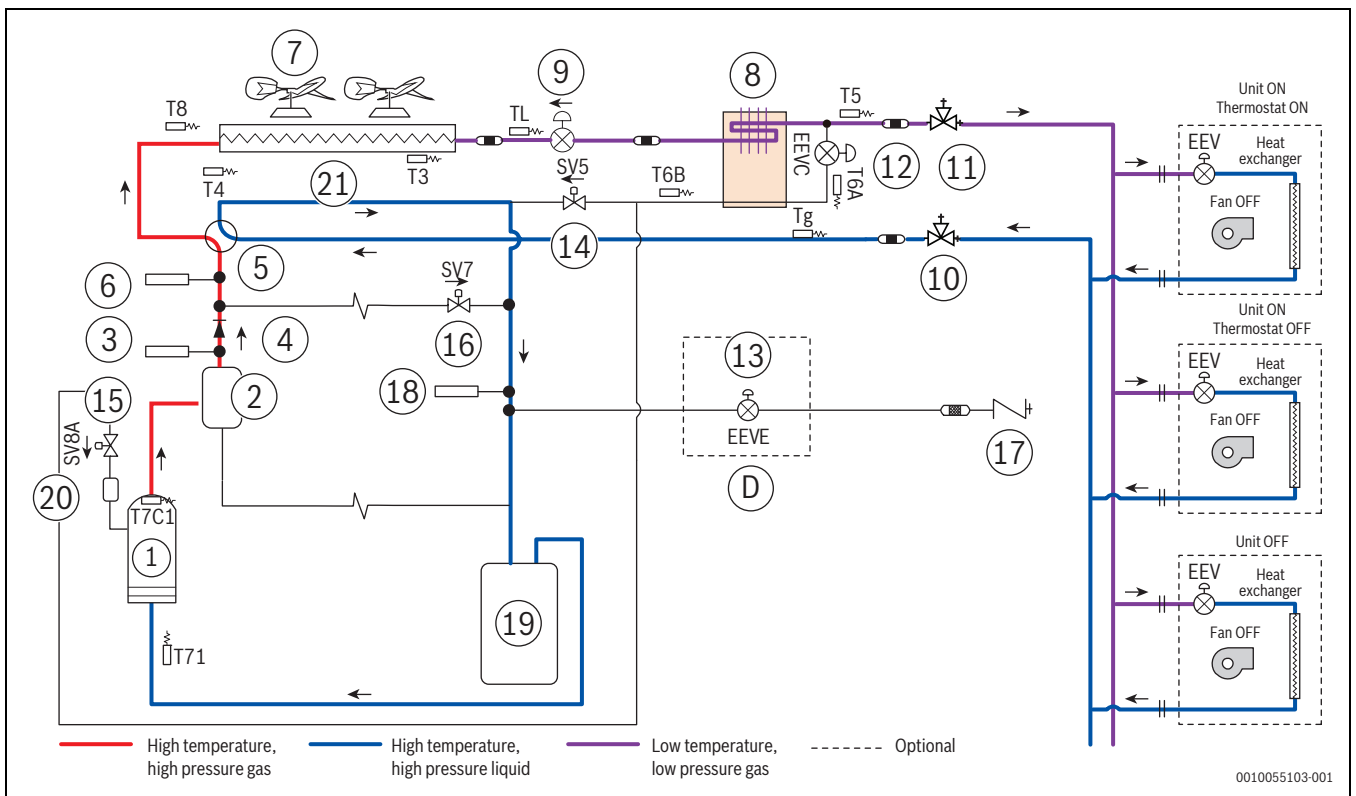

Fig. 14 Oil return operation in heating mode and defrosting operation (4-way valve, change direction)

AF5301A | A C 73-3 to AF5301A | A C 90-3

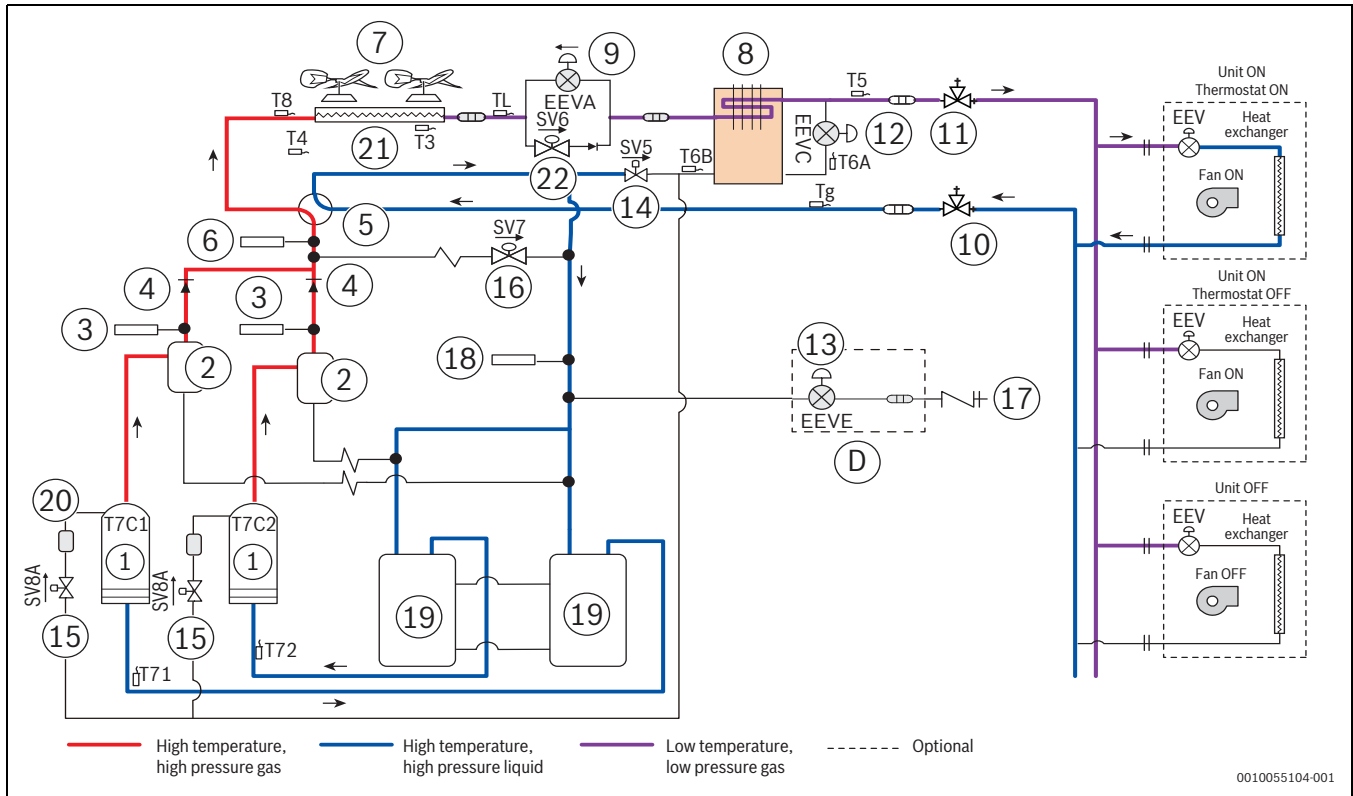

Fig. 15 Cooling operation

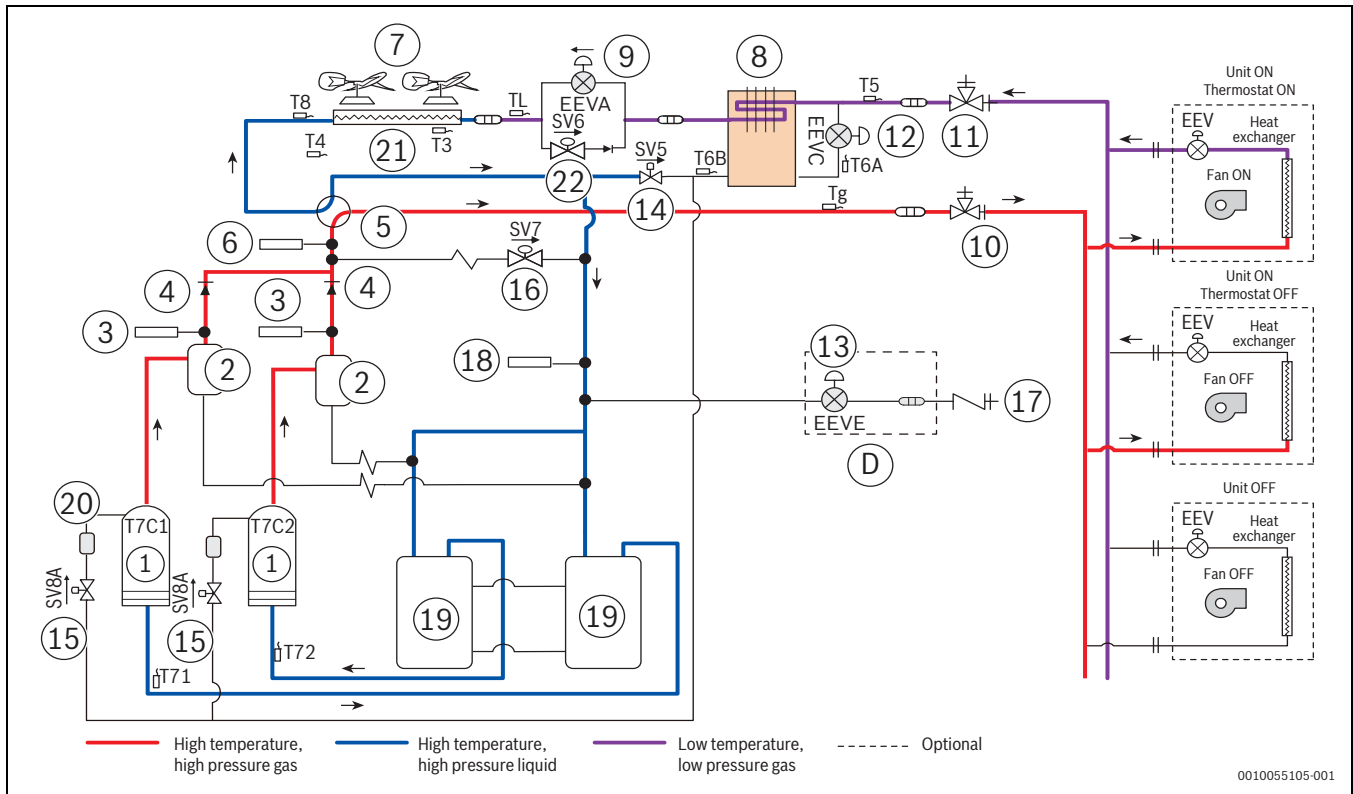

Fig. 16 Heating operation

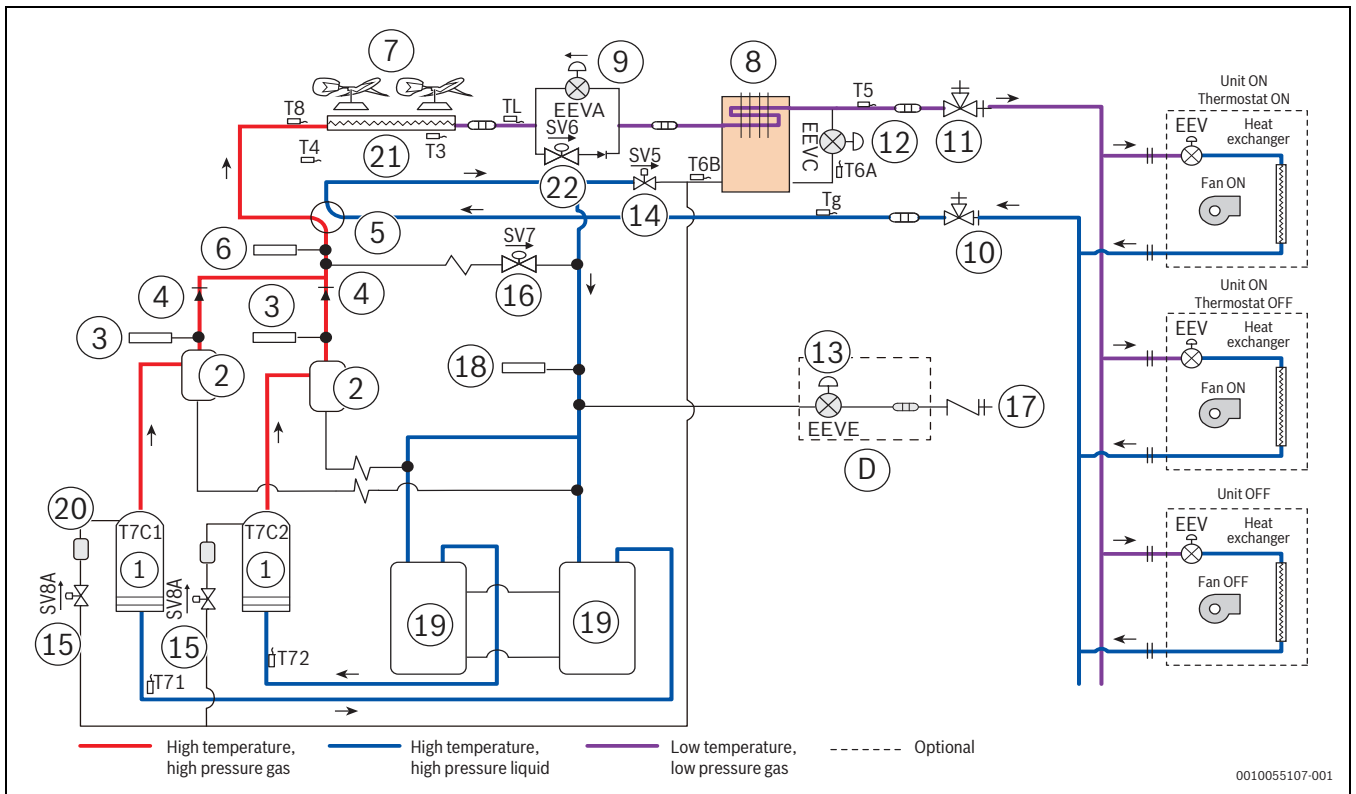

Fig. 17 Oil return operation in cooling mode

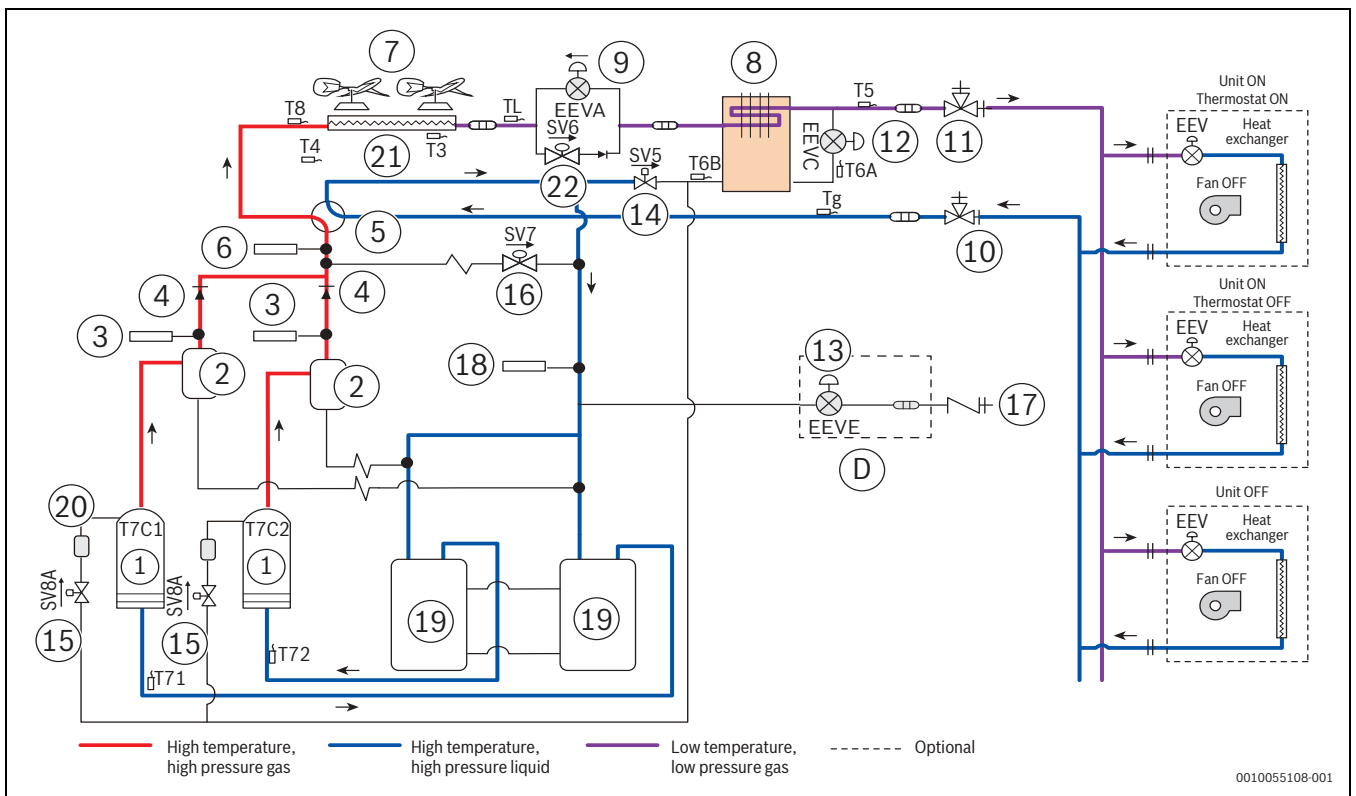

Fig. 18 Oil return operation in heating mode and defrosting operation (4-way valve, change direction)

4 Control

4.1 General control scheme flowchart

Sections 4.2 to 4.8 on the following pages detail when each of the controls in the flowchart below is activated.

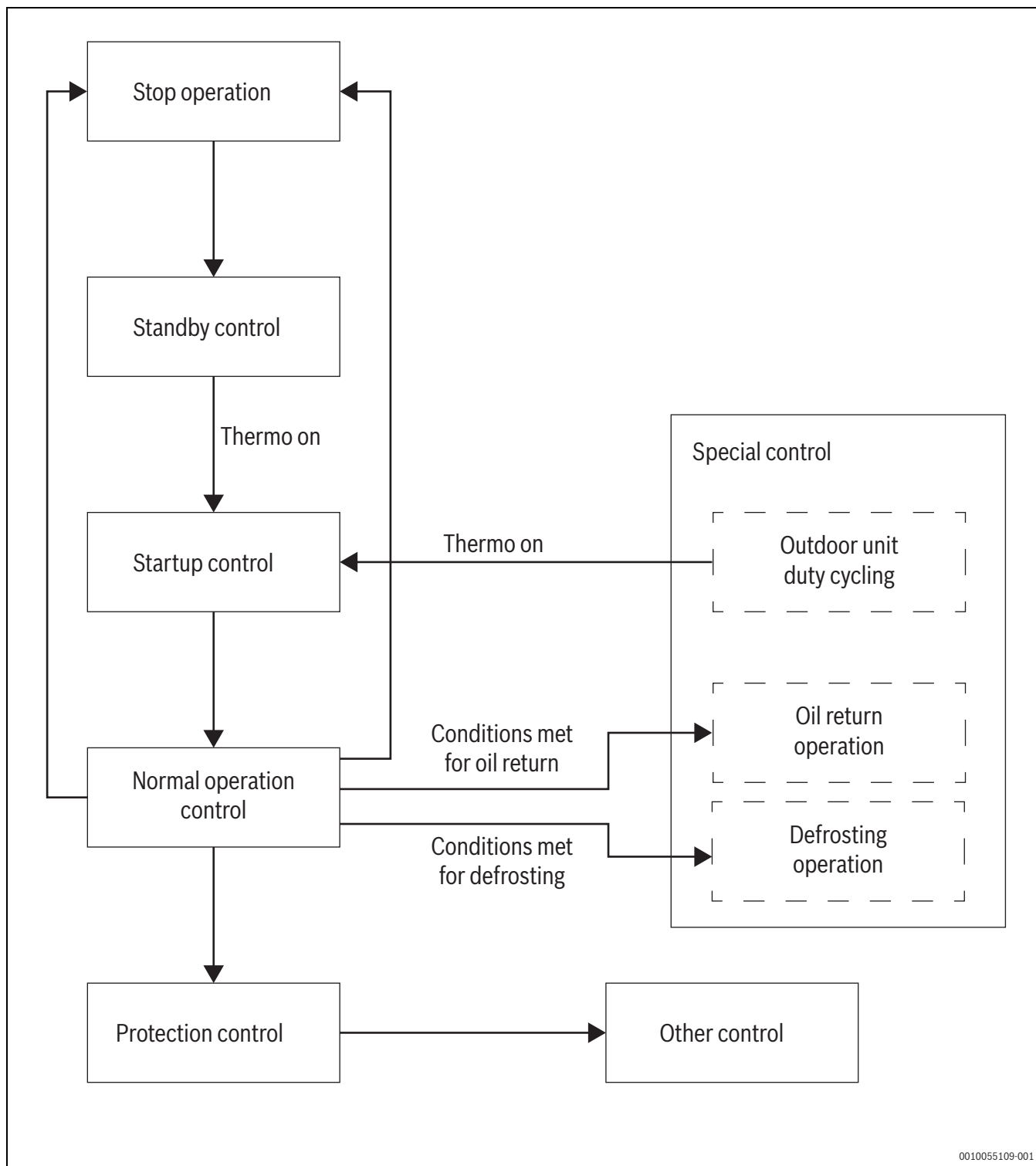

Fig. 19

4.2 Stop operation

The stop operation occurs for one of the two following reasons:

1. Abnormal shut-down: in order to protect the compressors, from an abnormal state the system makes a “stop with thermo off” operation and an error code is displayed on the outdoor unit’s digital display.
2. The system stops when the set temperature has been reached.
3. The ambient temperature is greater than 30 °C and the number of cooling Thermo on indoor unit is 0.

Part name	Symbol	Stop control	
Outdoor unit	Inverter compressor A	INV1	OFF
	Inverter compressor B ¹⁾	INV2	OFF
	Inverter fan 1	FANA	Stays ON for 2 min., then OFF
	Inverter fan 2 ²⁾	FANB	Holds
	Four-way valve	ST1	Cooling mode: 2880pls Heating mode: 0pls
	Electronic expansion valve	EEVA	Heating mode: 0pls
		EEVC	0pls
	Solenoid valve	SV5	ON for 140 sec, then OFF
		SV6 ³⁾	OFF
SV7		OFF	
SV8A/SV8B ¹⁾		OFF	

Table 9 Component control during stop operation

¹⁾ The inverter compressor B and SV8B are only available for the AF5301A | A C 73-3 to AF5301A | A C 90-3 series.

²⁾ The inverter fan 2 is only available for the AF5301A | A C 50-3 to AF5301A | A C 90-3 series.

³⁾ The SV6 is only available for the AF5301A | A C 73-3 to AF5301A | A C 90-3 series.

stopped. This delay is implemented to prevent frequent compressor on/off cycles and to equalize the pressure within the refrigerant system.

4.3 Standby control

The crankcase heater is used to prevent refrigerant from mixing with compressor oil when the compressors are stopped. The crankcase heater is controlled according to the minimum discharge temperatures. When the minimum discharge temperature gets above 45 °C, the crankcase heater is turned off. When the minimum discharge temperature gets below 40 °C, the crankcase heater turns on if one of the three following conditions is met:

- Initial power-up
- In defrost operation
- When the ambient temperature is below 10 °C, and the compressor remains off for over 4 hours

4.4 Start-up control

4.4.1 Start-up sequence and frequency control in combination modules

During the start-up procedure, the master outdoor unit uniformly assesses the control of the compressor and the heat exchange mode. The electronic expansion valve and solenoid valve in each slave unit self-assess based on their individual sensor statuses. The compressor frequency during start-up is determined by the displacement frequency of the 60cc compressor. After the main outdoor unit calculates and allocates the maximum frequency evenly to each slave unit, each slave unit adjusts its displacement frequency to the actual frequency. When starting combinational modules in parallel, the master outdoor unit initiates first, and each slave outdoor unit starts with a 5-second delay.

4.4.2 Compressor start-up delay control

During the initial start-up control, the compressor start-up is delayed for 3 minutes to allow the master unit to search for the addresses of the indoor units. In restart control (except during oil return operation and defrosting operation), the compressor start-up is delayed for a minimum of 3 minutes and a maximum of 12 minutes after the compressor has

4.4.3 Start-up control for cooling operation

Component		Wiring diagram label	Before start-up	Start-up control				
				STEP1	STEP2	STEP3	STEP4	STEP5
Outdoor unit	Inverter compressor A	INV1	0Hz	0Hz	0Hz	0Hz	Initial step for 30s, then increase of 8Hz x No. of outdoor units / 10s (until it reaches [Pc-Pe] _{min} ≥ 0.4MPa)	Adjust according to the high pressure and low pressure
	Inverter compressor B ¹⁾	INV2	0Hz	0Hz	0Hz	0Hz		
	Inverter fan 1	FANA	0 step	If T4 exceeds the operating range, the system will turn off after 2 minutes of operating in the 12th gear, and then remain off for a maximum of 3 cycles.	0 step	0 step	Start: 0 step, then adjust according to the high pressure and low pressure	PI control
	Inverter fan 2 ²⁾	FANB						
	Four-way valve	ST1	Maintains previous position			Determined based on the initial mode of the heat exchanger		
	Electronic expansion valve	EEVA	0pls	Compressor operation: T4 < 5 °C 480P EEV: 135pls; 3000P EEV: 1000pls T4 ≥ 5 °C 480P EEV: 320pls; 3000P EEV: 2000pls Compressor not operating, 0pls				
		EEVC	0pls	0pls			Compressor operation, 17pls and then, +8pls per 20s based on high pressure or discharge temperature. Compressor not operating, 0pls.	
Solenoid valve	SV5	OFF	ON					
	SV6 ³⁾	OFF	OFF			ON		
	SV8A/B ¹⁾	OFF	OFF				ON: Compressor in operation OFF: Compressor not operating	
	SV7	OFF to ON in 1 min.	OFF			ON if Pc ≥ 3.3MPa or Pe < 0.18MPa, otherwise is OFF		
Indoor unit	Fan	Fan	0 step	Setting speed by owners				
	Electronic expansion valve	EEV	0pls	0pls			Maintains 120pls for 2 min.	
Ending conditions			60S	T4 ≥ -15 and T4 ≤ 55	30s	30s	(Pc-Pe) _{min} ≥ 0.4 MPa or 60s	End if start-up time reaches 5 min. or the minimum superheat of discharge temperature ≥ 10 °C or Tc _{max.} > 50 °C

Table 10 Component control during start-up in cooling mode

¹⁾ The inverter compressor B and SV8B are only available for the AF5301A | A C 73-3 to AF5301A | A C 90-3 series.

²⁾ The inverter fan 2 is only available for the AF5301A | A C 50-3 to AF5301A | A C 90-3 series.

³⁾ The SV6 is only available for the AF5301A | A C 73-3 to AF5301A | A C 90-3 series.

4.4.4 Start-up control for heating operation

Component		Wiring diagram label	Before start-up	Start-up control				
				STEP1	STEP2	STEP3	STEP4	STEP5
Outdoor unit	Inverter compressor A	INV1	0Hz	0Hz	0Hz	0Hz	Initial step for 30s, then increase of 8Hz x No. of outdoor units / 10s (until it reaches [Pc-Pe] _{min} ≥ 0.4MPa)	Adjust according to the high pressure and low pressure
	Inverter compressor B ¹⁾	INV2	0Hz	0Hz	0Hz	0Hz		
	Inverter fan 1	FANA	0 step	0 step	0 step	0 step	Start: 0 step, then adjust according to the high pressure and low pressure	PI control
	Inverter fan 2 ²⁾	FANB						
	Four-way valve	ST1	Maintains previous position		Determined based on the initial mode of the heat exchanger			
	Electronic expansion valve	EEVA	Opls	Opls				Evaporator adjusted according to the difference between ambient temperature and low-pressure saturation temperature.
		EEVC	Opls	Opls				Compressor operation, 17pls and then, +8pls per 20s based on high pressure or discharge temperature. Compressor not operating, Opls.
	Solenoid valve	SV5	OFF	ON				
SV8A/B ¹⁾		OFF	OFF					ON: Compressor in operation OFF: Compressor not operating
SV7		OFF to ON in 1 min.	OFF				ON if Pc ≥ 3.3MPa or Pe < 0.18MPa, otherwise is OFF	
Indoor unit	Fan	Fan	0 step	Setting speed by owners (Anti-cold wind function is activated)				
	Electronic expansion valve	EEV	300pls	300pls		Maintains 300pls for 3 min.		
Ending conditions			60S	T4 ≤ 30	30s	30s	Pc-Pe > 0.3MPa or 60s	End if start-up time reaches 10 min. or the minimum super-heat of discharge temperature ≥ 10 °C for 5 min. or Tc _{max} > 50 °C

Table 11 Component control during start-up in heating mode

¹⁾ The inverter compressor B and SV8B are only available for the AF5301A | A C 73-3 to AF5301A | A C 90-3 series.

²⁾ The inverter fan 2 is only available for the AF5301A | A C 50-3 to AF5301A | A C 90-3 series.

4.5 Normal operation control

4.5.1 Component control during normal operation

Component	Wiring diagram label	Cooling	Heating
Inverter compressor A	COMP (A)	PI control, High pressure protection, Low pressure protection, Discharge temperature protection, Inverter over-current protection control, Inverter module temperature protection control, Wet compression protection control, High pressure ratio protection control	
Inverter compressor B ¹⁾	COMP (B)		
Inverter fan 1	FANA	PI control	PI control
Inverter fan 2 ²⁾	FANB		
Electronic expansion valve	EEVA	Sub-cooling control	Outdoor unit super-heat control, Discharge pipe temperature super-heat control
	EEVC	Super-heat control	Super-heat control
Four-way valve	ST1	OFF	ON
Solenoid valve (fast defrosting [in heating] and unloading [in cooling])	SV5	ON	OFF: Ambient temperature < 12 °C, heat exchanger acts as evaporator and DSH ≥ 20 °C
Solenoid valve (micro-channel heat exchanger flow control)	SV6 ³⁾	Sub-cooling control	OFF
Solenoid valve (indoor units bypass)	SV7	ON when the low pressure is too low or the high pressure is too high	
Solenoid valve (inverter compressor A/B vapour injection)	SV8A/ SV8B ¹⁾	ON: Compressor in operation OFF: Compressor not operating	

Table 12 Component control during normal operation

¹⁾ The inverter compressor B and SV8B are only available for the AF5301A | A C 73-3 to AF5301A | A C 90-3 series.

²⁾ The inverter fan 2 is only available for the AF5301A | A C 50-3 to AF5301A | A C 90-3 series.

³⁾ The SV6 is only available for the AF5301A | A C 73-3 to AF5301A | A C 90-3 series.

Component		Cooling	Heating
Fan	Thermo ON unit	Remote controller setting	Remote controller setting
	Stopping unit	OFF	OFF
	Thermo OFF unit	Remote controller setting	Remote controller setting
Electronic expansion valve (EEV)	Thermo ON unit	Super-heat control	Sub-cooling control
	Stopping unit	0pls	56pls/72pls/ according to the setting
	Thermo OFF unit	0pls	56pls/72pls/ according to the setting

Table 13 Component control during normal operation

4.5.2 Compressor control

Cooling operation

In the cooling operation, the compressor frequency is PI controlled to maintain a low pressure at the target temperature.

Te: Low-pressure equivalent saturation temperature (°C)

Tes: Target Te value.

Tes value is determined by the Te setting. If you choose Auto, it means that, apart from the Te setting, Tes will be adjusted based on factors such as ambient temperature, refrigerant pipe length, etc.

Setting	0	1	2	3 (default)	4	5	6	7	8
Tes (°C)	-3 (fixed)	0 (fixed)	3 (fixed)	6 (auto)	7 (fixed)	8 (fixed)	9 (fixed)	10 (fixed)	11 (fixed)

Table 14 Te setting

Heating operation

In the heating operation, the compressor frequency is PI controlled to keep high pressure at target temperature.

Tcs will be determined by the Tc setting. If you choose Auto, it implies that, beyond the Tc setting, Tcs will be adjusted based on factors such as ambient temperature, refrigerant pipe length, etc.

Tc: High pressure equivalent saturation temperature (°C)

Tcs: Target Tc value.

Setting	0	1	2	3	4	5	6 (default)	7
Tcs (°C)	41 (fixed)	42 (fixed)	43 (fixed)	44 (auto)	45 (fixed)	46 (fixed)	48 (fixed)	51 (fixed)

Table 15 Tc setting

Simultaneous cooling and heating operation

It controls compressor capacity to adjust Tc to target value (Tcs) and Te to target value (Tes).

4.5.3 Rotation of the compressors

To ensure equal operating time for each compressor in combination with outdoor units, the outdoor units are utilized in rotation.

The compressor rotation in systems with two and three units is shown in Figures 20 and 21. The master unit and slave units 1 and 2 are presented from left to right, following the sequence indicated by the numbers 1 to 6. It is important to note that the provided rotation sequence is only an example, and the actual rotation is determined by the cumulative time of operation of each unit.

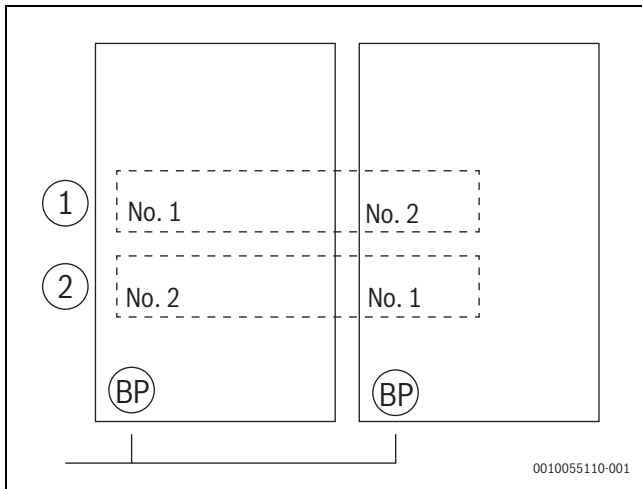

Fig. 20 Priority and rotation of the compressor (two outdoor units)

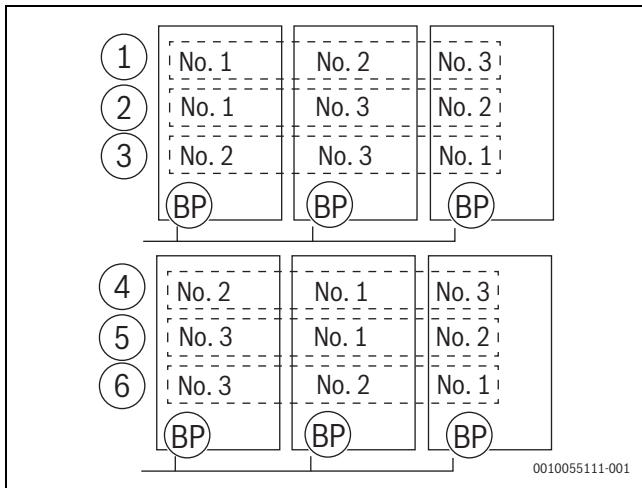

Fig. 21 Priority and rotation of the compressor (three outdoor units)

4.5.4 Heat exchanger control

The mode of the outdoor units is uniformly controlled by the master outdoor unit. The master outdoor unit assesses the status of the outdoor unit heat exchanger and communicates the calculation results to each slave unit. Each slave unit then independently controls its own four-way valve, fan, and EEVA.

4.5.5 Electronic expansion valve control

EEVA control

The positions of the electronic expansion valves EEVA are controlled in steps from 0/0 (fully closed) to 480/2880 (fully open).

The outdoor unit heat exchanger is performed through the evaporator if:

- The outdoor unit is $\geq -8^\circ\text{C}$
 This function applies PI control to the electronic expansion valve (EEVA) to maintain a constant evaporator outlet superheat degree (SH).
 $SH = T8 - Te$
 Where:
 SH: Evaporator outlet superheated degree ($^\circ\text{C}$)
 T8: Evaporator outlet temperature ($^\circ\text{C}$)
 Te: Low pressure equivalent saturation temperature ($^\circ\text{C}$)
- The outdoor unit is $< -10^\circ\text{C}$
 This function applies PI control to the electronic expansion valve (EEVA) to ensure that the minimum of discharge temperatures (T7C_min) reaches the target discharge temperature (T7CS).
 $T7CS = 3 \times PR + 12 + Tc$
 Where:
 T7CS: Target discharge temperature value
 T7C_min: The minimum of discharge temperatures
 Tc: High-pressure equivalent saturation temperature ($^\circ\text{C}$)
 PR: Pressure ratio, $Pr = (Pc + 0.11) / (Pe + 0.1)$

The outdoor unit heat exchanger is performed through the condenser:
 This function applies PI control to the electronic expansion valve (EEVA) to maintain a constant condenser outlet sub-cooled degree (SC).

- $SC = Tc - TL$
 Where:
 SC: Condenser outlet sub-cooled degree ($^\circ\text{C}$)
 TL: Condenser outlet temperature ($^\circ\text{C}$)
 Tc: High pressure equivalent saturated

4.5.6 EEVC control

This function applies PI control to the electronic expansion valve (EEVC), adjusting its positions from 0 (fully closed) to 480 (fully open).
 The aim is to optimize the use of the micro-channel heat exchanger by maintaining a constant super-heated degree at the outlet (SH) or a constant discharge temperature (T7C1/T7C2).

- $SH = T6B - T6A$
 Where:
 SH: Micro-channel heat exchanger outlet superheated degree ($^\circ\text{C}$)
 T6A: Micro-channel heat exchanger inlet temperature
 T6B: Micro-channel heat exchanger outlet temperature

4.5.7 Outdoor fan control

The speed of the outdoor unit fans is adjusted in steps, as shown in the Table 16.

A standard step means the max. step in standard static pressure mode (OPa default).

Fan speed index	Fan speed (rpm)			Observation	
	25-45kW	50-67kW (FANA/FANB)	73-90kW (FANA/FANB)	Cooling (Stop operation/Start-up or defrosting control) ¹⁾	Heating (Start-up or defrosting control) ¹⁾
0	0	0	0		
1	120	150	120		
2	130	180	150		
3	140	250	170		
4	150	250	190		
5	170	270 (150/150)	250		
6	190	300 (180/180)	250		
7	250	330 (250/250)	250/120/120)		
8	250	360 (250/250)	270 (150/150)		
9	250	270/270	330 (170/170)		
10	280	300/300	370 (190/190)		
11	310	330/330	250/250		
12	340	360/360	250/250		
13	370	390/390	250/250		
14	400	420/420	270/270		
15	430	460/460	290/290		
16	460	500/500	310/310		
17	500	540/540	330/330		
18	530	580/580	350/350		
19	560	620/620	370/370		
20	600	660/660	400/400		
21	630	710/710	430/430		
22	660	760/760	470/470		
23	700	810/810	510/510	8/10	8/10
24	750	860/860	550/550		12
25	800	910/910	600/600	12	
26	880	960/960	650/650	14/16	14/16
27	890	1000/1000	700/700		
28	920	1040/1040	750/750		
29	960	1080/1080	800/800		
30	1020	1120/1120	830/830		
31	1050	1210/1100	850/850	26	26
32	1090	1230/1130	870/870	28/30/32	18/20/11/24/28/30/32
33	1130	1250/1150	890/890	18/20/22/24	
34	1170	1230/1230	920/920		
35	1210	1270/1270	950/950		
36		1330/1330	980/980		
37		1390/1390	1030/1030		
38		1440/1440	1070/1070		
39		1490/1490	1100/1100		
40		1540/1540	1140/1140		

Table 16 Outdoor fan speed steps

¹⁾In Cooling mode, when the operation stops, during start-up, or in defrosting, the maximum achievable fan speed index for a 90kW unit is 32.

Static pressure mode (Pa)	Unit (kW)												
	25	28	33	40	45	50	56	62	67	73	79	85	90
0 (default)	23	23	24	26	26	32	32	32	32	31	32	32	32
20	24	24	25	29	29	34	34	34	34	32	33	33	33

Table 17 Cooling - Upper limit fan step in static pressure mode

Static pressure mode (Pa)	Unit (kW)												
	25	28	33	40	45	50	56	62	67	73	79	85	90
0 (default)	23	23	25	26	26	33	33	33	33	31	32	32	32
20	24	24	25	29	29	34	34	34	34	33	34	34	34

Table 18 Heating - Upper limit fan step in static pressure mode

4.6 Protection control

4.6.1 High pressure protection control

This control protects the system from abnormally high pressure and protects the compressors from transient spikes in pressure.

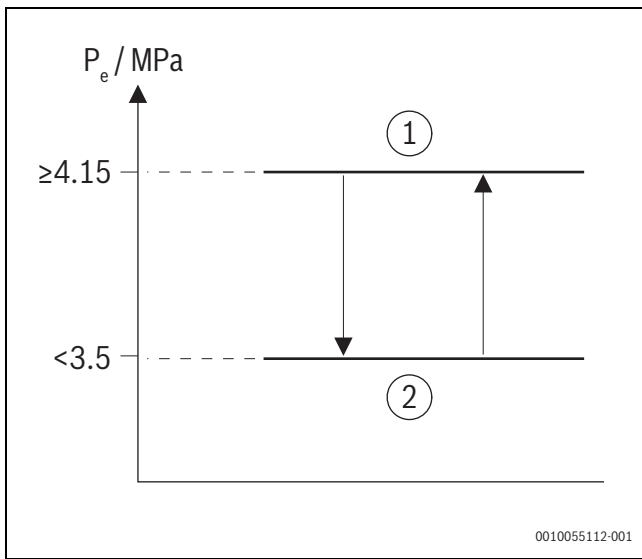

Fig. 22 High pressure protection control

- [1] Normal operation
- [2] High pressure protection, error code P12 is displayed
- P_c Discharge pressure

4.6.2 Low pressure protection control

This control protects the system from abnormally low pressure and protects the compressors from transient drops in pressure.

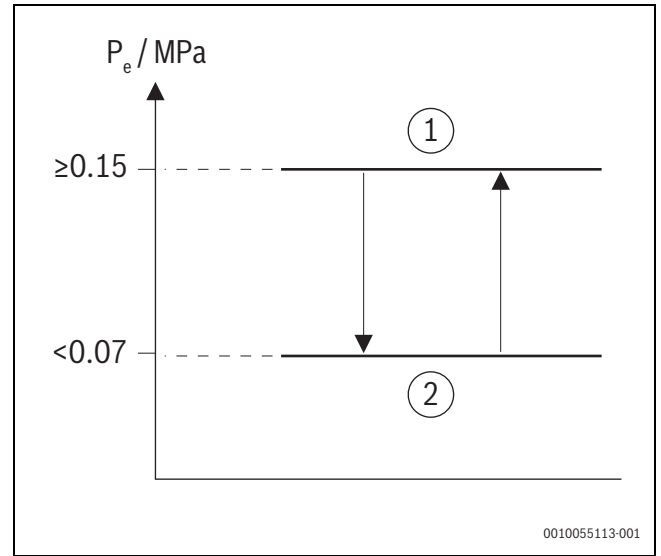

Fig. 23 Low pressure protection control

- [1] Normal operation
- [2] Low pressure protection, error code P22 is displayed

P_e Suction pressure

When P22 protection occurs 3 times in 60 minutes, the P25 error is displayed. When a P25 error occurs, a manual system restart is required before the system can resume operation.

4.6.3 Discharge temperature protection control

This control protects the compressors from abnormally high temperatures and transient spikes in temperature. It is performed for each compressor.

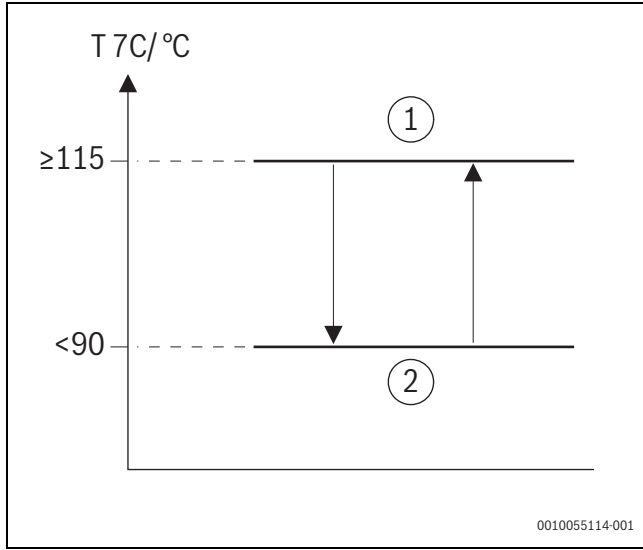

Fig. 24 Discharge temperature protection control

- [1] Normal operation
 - [2] Discharge temperature protection, error code F72 is displayed
- T7C Max. temperature of the compressor discharge temperatures
- When the max. temperature of the compressor discharge temperature rises above 115°C the system displays F72 protection and all units stop running. When F72 protection occurs 3 times in 100 minutes, the F7A

error is displayed. When an F7A error occurs, a manual system restart is required before the system can resume operation.

4.6.4 Over-current protection control

The over-current protection control is performed to prevent tripping due to transient inverter over-current. It protects the compressors from abnormally high currents. It is performed for each compressor.

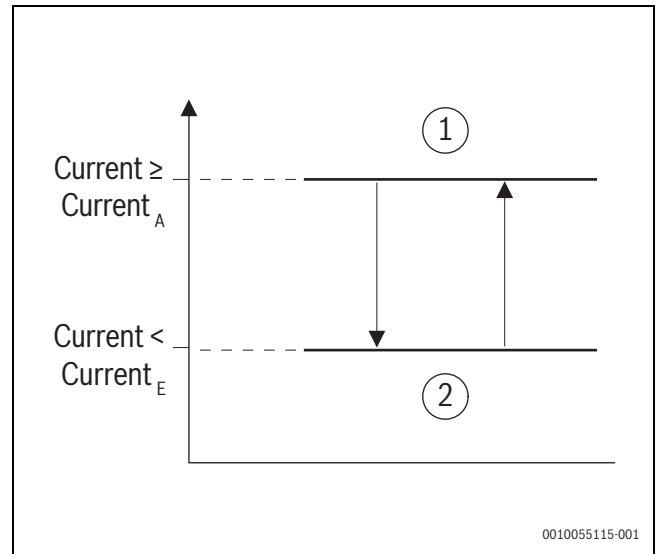

Fig. 25 Compressor current protection control

- [1] Normal operation
- [2] Over-current protection, error code xP32 is displayed

Model		25kW	28kW	33kW	40kW	45kW	50kW	56kW	62kW	67kW
AF5301A	Current _A	32.5	32.5	32.5	42	42	53	53	53	53
	Current _E	25	25	25	34.5	34.5	43	43	43	43
AF5301A C	Current _A	32.5	32.5	32.5	42	42	53	53	53	53
	Current _E	25	25	25	34.5	34.5	43	43	43	43

Table 19

Model		73kW		79kW		85kW		90kW	
		INVA	INVB	INVA	INVB	INVA	INVB	INVA	INVB
AF5301A	Current _A	32.5	32.5	32.5	46	32.5	46	32.5	46
	Current _D	25	25	25	34.5	25	34.5	25	34.5
AF5301A C	Current _A	32.5	32.5	32.5	46	32.5	46	32.5	46
	Current _D	25	25	25	34.5	25	34.5	25	34.5

Table 20

4.6.5 Ambient temperature out of range protection control

When the outdoor ambient temperature rises above 30.5°C heating mode is disabled to prevent the mechanical load on compressors becoming too high and to prevent low compression ratios which can result in insufficient compressor internal oil lubrication.

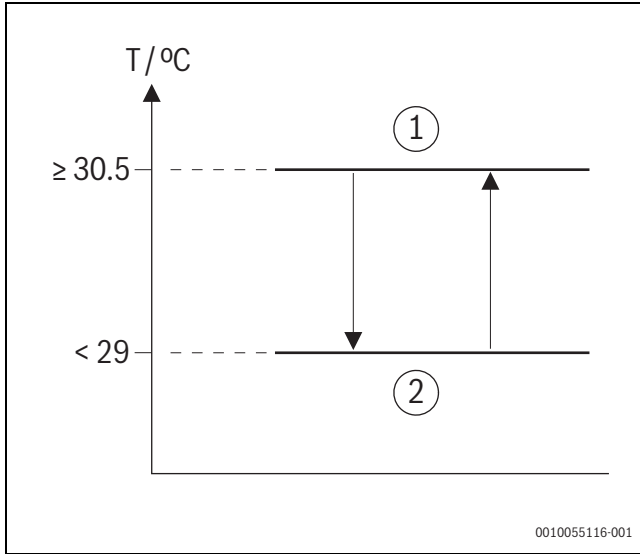

Fig. 26

- [1] Heating operation
- [2] Units stops
- T Outdoor ambient temperature

When the outdoor ambient temperature rises above 55°C or outdoor ambient temperature drops below -16°C, the cooling mode is disabled to protect the compressor.

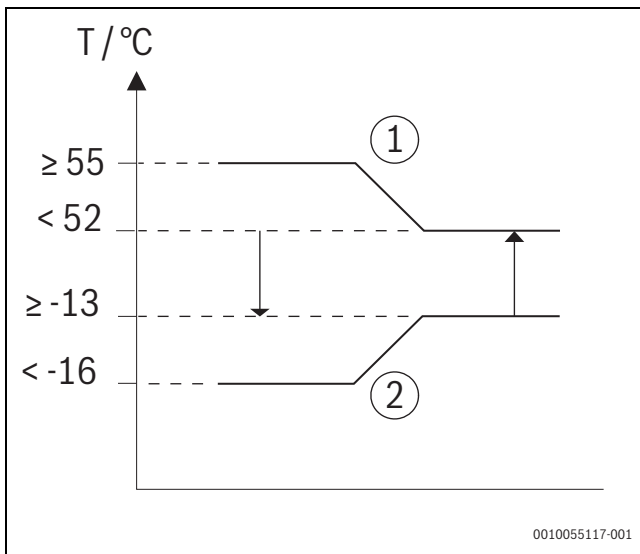

Fig. 27

- [1] Cooling operation
- [2] Units stops
- T Outdoor ambient temperature



If the indoor unit operates in cooling mode below -5 °C, the temperature of the indoor unit's air outlet may be lower than 0 degrees.

4.6.6 Inverter module temperature protection control

This control protects the compressors from abnormally high currents and protects the inverter modules from abnormally high temperatures. It is performed for each compressor and inverter module.

Error code F62

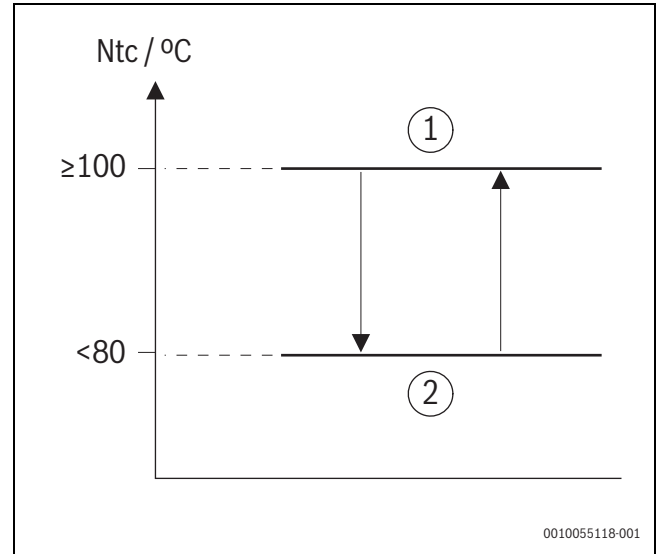

Fig. 28

- [1] Normal operation
- [2] Inverter module temperature protection, error code F62 is displayed

Ntc Inverter module temperature

When F62 protection occurs 3 times in 100 minutes, the F6A error is displayed. When a F6A error occurs, a manual system restart is required before the system can resume operation.

Error code F63

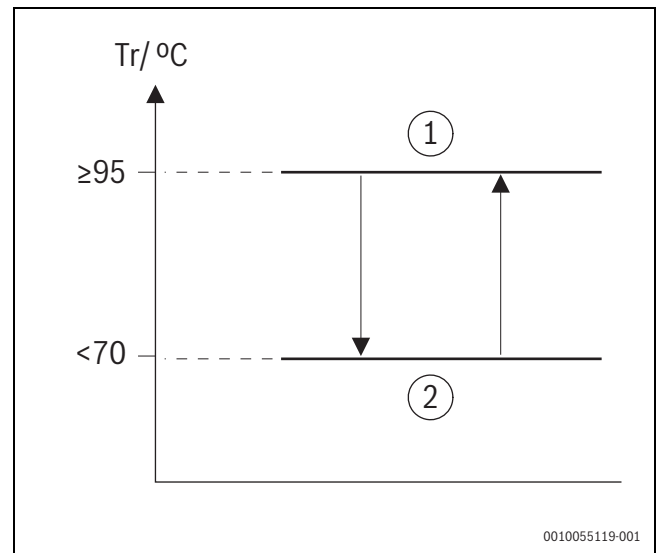

Fig. 29

- [1] Normal operation
- [2] Non-inductance resistors temperature protection, error code F63 is displayed

Tr Non-inductance resistors temperature

4.6.7 Wet compression protection control

This protection is used to prevent compressor from damaging for the long time wet compression so that it cannot be lubricated well. This control is performed for each compressor.

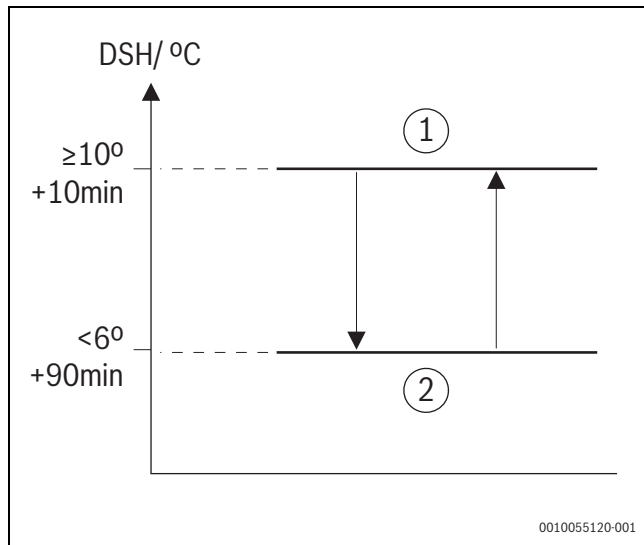

Fig. 30

- [1] Normal operation
 - [2] Wet compression protection, error code F75 is displayed
- DSH Super-heat of discharge temperature

4.6.8 High pressure ratio protection control

This high pressure ratio protection control is used to prevent the activation of protection devices due to abnormal increase of high pressure ratio, and to protect compressors against the transient increase of high pressure ratio. It is performed for entire system.

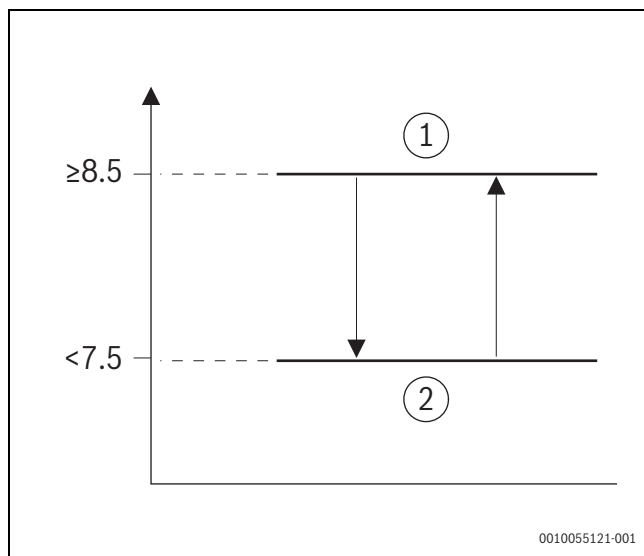

Fig. 31

- [1] Normal operation
- [2] High pressure ration protection, compressor frequency is limited

P_c Discharge pressure

P_e Suction pressure

$$\text{Pressure ration} = (P_c + 0.11) / (P_e + 0.10)$$

4.7 Special control

4.7.1 Oil return operation

In order to prevent compressors from running out of oil, the oil return operation is conducted to recover oil that has flowed out of the compressor(s) and into the piping system. This operation is performed for all units including units that are in standby. When the outdoor unit is running in oil return, the digital display on outdoor main PCB will display “d0”.

Timing of oil return operation:

- Calculated oil discharge has reached to specified level. The higher the compressor frequency step is, the more oil discharge.
- Initial cumulative compressor operating time reaches 2 hours.
- Cumulative compressor operating time reaches 8 hours.

Tables 21 and 22 show component control during oil return operation in cooling mode.

Component		Wiring diagram label	Cooling oil return control			
			STEP1	STEP2	STEP3	STEP5
Outdoor unit	Inverter compressor A	INV1	PI control	PI control, the minimum step is as follows: 25kw = 27Hz 28 = 39Hz 33-40 = 52Hz 45-67 = 69Hz 73 = 99Hz 79-90 = 108Hz	PI control, initial outdoor unit number is decided	PI control
	Inverter compressor B ¹⁾	INV2				
	Inverter fan 1	FANA	PI control			
	Inverter fan 2 ²⁾	FANB				
	Four-way valve	ST1	OFF			
	Electronic expansion valve	EEVA	PI control	2880pls	PI control	
		EEVC	OFF, then 17pls	17pls	17pls	PI control
	Solenoid valve	SV5	ON			
		SV6 ³⁾	ON			
		SV8A/B ¹⁾	ON: Compressor ON OFF: Compressor OFF			
SV7		Turns ON/OFF based on the low and high pressures, etc.				
Ending conditions			End if start-up time reaches 180s.	End if start-up time reaches 6 min. or the compressor discharge volume is ≥ target value for 4 min.	After 20s.	After 2 min.

Table 21 Outdoor unit component control during oil return operation in cooling mode

¹⁾ The inverter compressor B and SV8B are only available for the AF5301A | A C 73-3 to AF5301A | A C 90-3 series.

²⁾ The inverter fan 2 is only available for the AF5301A | A C 50-3 to AF5301A | A C 90-3 series.

³⁾ The SV6 is only available for the AF5301A | A C 73-3 to AF5301A | A C 90-3 series.

Component	Unit state	500P EEV
Fan	Thermo on	Keeps the previous fan speed
	Thermo off	
	Stop or fan	
Electronic expansion valve (EEV)	Thermo on	Super-heat control
	Thermo off	80pls
	Stop or fan	80pls

Table 22 Indoor unit component control during oil return operation in cooling mode

Heating oil return control

Refer to Chapter 4.7.2 "Defrosting operation".

4.7.2 Defrosting operation

In order to recover heating capacity, the defrosting operation is conducted when the outdoor unit heat exchanger is performing as an evaporator. The defrosting operation is controlled according to outdoor ambient temperature, outdoor heat exchanger temperature, indoor heat exchanger temperature and outdoor units running time. When the

outdoor unit is running in defrosting, the digital display on outdoor main PCB will display "df".

Timing of reserve cycle defrosting operation

Te < -2°C and T4 < 20°C, meeting either of the points below:

- When there is an obviously drop in the temperature of outdoor unit heat exchanger outlet.
- When cumulative operating time after the latest defrosting control arrives an hour.
- Compulsive defrosting or oil return set manually after PI control 1min.

Component		Wiring diagram label	Defrosting operation control					
			Control before defrosting	Defrosting control	Control after defrosting			
Outdoor unit	Inverter compressor A	INV1	Reduce frequency step	25kW = 74Hz 28kW = 74Hz 33kW = 74Hz 40kW = 75Hz 45kW = 80Hz 50kW = 80Hz 56kW = 99Hz 62kW = 99Hz 67kW = 105Hz 73kW = 105Hz 79kW = 148Hz 85kW = 148Hz 90kW = 148Hz	PI control, initial outdoor unit number is decided			
	Inverter compressor B ¹⁾	INV2						
	Inverter fan 1	FANA				PI control	Initial OFF, but if the high pressure is superior to 2.2MPa, turn to 10 step or higher	Initial step then PI control
	Inverter fan 2 ²⁾	FANB						
	Four-way valve	ST1				ON	OFF	ON
	Electronic expansion valve	EEVA				2880pls/480pls		
		EEVC				Opls	Initial 17 step, then +32pls or -32pls per 30s based on high pressure or discharge temperature, etc.	17pls, then PI control
	Solenoid valve	SV5				ON		
		SV6 ³⁾				OFF	ON	OFF
		SV8A/B ¹⁾				ON: Compressor ON OFF: Compressor OFF	OFF	ON: Compressor ON OFF: Compressor OFF
SV7		Turns ON/OFF based on the low and high pressures, etc.						
Ending conditions			End if Pc-Pe < 0.4Mpa, max. 120s	Defrost completion condition judgement, max. time is 9 min.	9 min.			

Table 23 Outdoor unit component control during defrosting operation

¹⁾ The inverter compressor B and SV8B are only available for the AF5301A | A C 73-3 to AF5301A | A C 90-3 series.

²⁾ The inverter fan 2 is only available for the AF5301A | A C 50-3 to AF5301A | A C 90-3 series.

³⁾ The SV6 is only available for the AF5301A | A C 73-3 to AF5301A | A C 90-3 series.

Defrosting control time is no less than 135s and fulfill one of the conditions below:

- Pc-max ≥ 3.0MPa.
- Total defrosting control time has reached 9 minutes.
- T3_min > Target value for a certain time.

Component	Unit state	500P EEV
Fan	Thermo on	OFF
	Thermo off	OFF
	Stop	OFF
Electronic expansion valve (EEV)	Thermo on	Within 2min.: 480pls
	Thermo off	2 to 4 min.: 300pls
	Stop	After 4 min.: 120 pls

Table 24 Indoor unit component control during defrosting operation

4.8 Other controls

4.8.1 Overload control

This control maintains comfort requirement (i.e. outlet air temperature) and keeps and adequate system pressure.

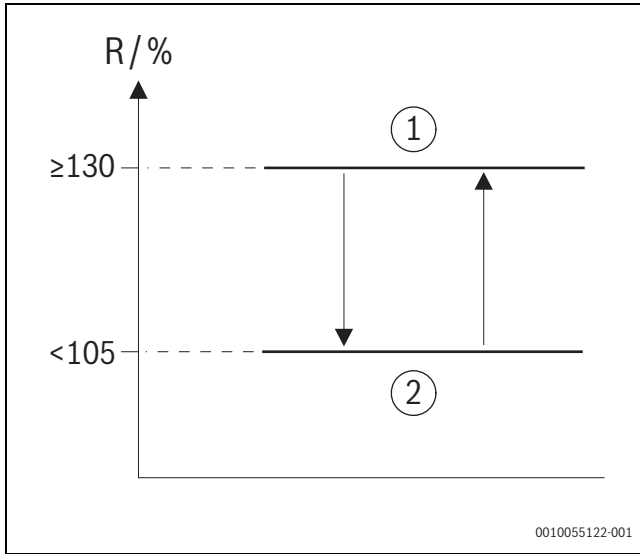

Fig. 32 Overload control

- [1] Normal operation
 - [2] Overload control, indoor unit operates at low fan speed
- R Operation ratio of the indoor unit

Operation ratio of the indoor unit = Indoor unit capacity index (in the same mode) / outdoor unit capacity index

4.8.2 Vacuum control

This control opens the solenoid valves and electronic expansion valves throughout the system. During vacuum work, high/low pressure sensor errors and low-pressure protection should be ineffective (use short connectors if not). The four-way valve is turned OFF, and compressors or fans are prohibited from running.

4.8.3 Auto snow-blowing control

This control prevents the fans of stopped outdoor units from being damaged by heavy snow.

Timing of Auto snow-blowing operation:

Auto snow-blowing operation is initiated when $T_4 \leq 3^\circ\text{C}$, and the outdoor units have been stopped for a duration of TA.

When $T_4 > 3^\circ\text{C}$ or the outdoor unit starts operation, the time accumulated for Auto snow-blowing is reset to 0.

Model	Fan step	TA: level a (menu mode n261)	TA: level b (menu mode n262)	Disabled (menu mode n260, default)
25-90kW	15	30 min.	15 min.	/

Table 25 Snow-blowing control

4.8.4 Low noise mode

This control decreases the noise produced by outdoor units. There are 14 kinds of low noise mode: Silent mode 1 - Silent mode 14. When

activated, the low noise mode restricts both the fan step and compressor, contributing to a quieter operation.

ODU (kW)		Silent mode 1		Silent mode 2		Silent mode 3		Silent mode 4		Silent mode 5		Silent mode 6	
		Max. fan step	Max. freq. step	Max. fan step	Max. freq. step	Max. fan step	Max. freq. step	Max. fan step	Max. freq. step	Max. fan step	Max. freq. step	Max. fan step	Max. freq. step
25	Cool	23	105	22	95	20	86	19	81	17	71	15	60
	Heat	24	110	23	107	22	98	21	88	20	84	19	79
28	Cool	23	105	22	95	20	86	19	81	17	71	15	60
	Heat	24	110	23	107	22	98	21	88	20	84	19	79
33	Cool	23	105	22	95	20	86	19	81	17	71	15	60
	Heat	24	110	23	107	22	98	21	88	20	84	19	79
40	Cool	25	113	24	104	23	101	22	95	20	90	19	83
	Heat	25	128	25	122	23	102	23	98	22	92	20	86
45	Cool	25	113	24	104	23	101	22	95	20	90	19	83
	Heat	25	128	25	122	23	102	23	98	22	92	20	86
50	Cool	27	80	23	64	23	62	22	59	21	56	21	51
	Heat	30	88	28	83	25	70	23	62	22	59	21	54
56	Cool	27	80	23	64	23	62	22	59	21	56	21	51
	Heat	30	88	28	83	25	70	23	62	22	59	21	54
62	Cool	28	102	26	94	23	84	23	77	23	70	21	70
	Heat	30	116	28	104	26	96	25	94	24	86	23	77
67	Cool	28	102	26	94	23	84	23	77	23	70	21	70
	Heat	30	116	28	104	26	96	25	94	24	86	23	77
73	Cool	28	103+103	26	95+95	23	84+84	23	76+76	23	71+71	21	71+71
	Heat	30	117+117	28	105+105	26	98+98	25	95+95	24	86+86	23	76+76
79	Cool	29	108+108	28	107+107	27	100+101	25	91+90	25	86+86	24	79+78
	Heat	29	112+113	28	110+110	28	103+102	27	96+96	26	93+92	25	88+89
85	Cool	29	108+108	28	107+107	27	100+101	25	91+90	25	86+86	24	79+78
	Heat	29	112+113	28	110+110	28	103+102	27	96+96	26	93+92	25	88+89
90	Cool	29	108+108	28	107+107	27	100+101	25	91+90	25	86+86	24	79+78
	Heat	29	112+113	28	110+110	28	103+102	27	96+96	26	93+92	25	88+89

Table 26 Low noise mode

ODU (kW)		Silent mode 7		Silent mode 8		Silent mode 9		Silent mode 10		Silent mode 11		Silent mode 12	
		Max. fan step	Max. freq. step	Max. fan step	Max. freq. step	Max. fan step	Max. freq. step	Max. fan step	Max. freq. step	Max. fan step	Max. freq. step	Max. fan step	Max. freq. step
25	Cool	12	52	11	47	10	43	10	36	10	33	10	26
	Heat	17	72	16	67	14	59	12	52	10	45	10	40
28	Cool	12	52	11	47	10	43	10	36	10	33	10	26
	Heat	17	72	16	67	14	59	12	52	10	45	10	40
33	Cool	12	52	11	47	10	43	10	36	10	33	10	26
	Heat	17	72	16	67	14	59	12	52	10	45	10	40
40	Cool	17	77	16	71	16	62	13	50	11	44	9	41
	Heat	19	80	17	72	16	65	14	59	13	54	11	47
45	Cool	17	77	16	71	16	62	13	50	11	44	9	41
	Heat	19	80	17	72	16	65	14	59	13	54	11	47
50	Cool	20	46	18	41	16	38	14	34	13	29	13	29
	Heat	20	49	18	44	16	39	14	34	13	29	13	29
56	Cool	20	46	18	41	16	38	14	34	13	29	13	29
	Heat	20	49	18	44	16	39	14	34	13	29	13	29
62	Cool	20	64	20	58	18	52	16	50	14	44	12	40
	Heat	22	70	21	66	20	58	18	52	16	48	14	40

ODU (kW)		Silent mode 7		Silent mode 8		Silent mode 9		Silent mode 10		Silent mode 11		Silent mode 12	
		Max. fan step	Max. freq. step	Max. fan step	Max. freq. step	Max. fan step	Max. freq. step	Max. fan step	Max. freq. step	Max. fan step	Max. freq. step	Max. fan step	Max. freq. step
67	Cool	20	64	20	58	18	52	16	50	14	44	12	40
	Heat	22	70	21	66	20	58	18	52	16	48	14	40
73	Cool	20	64+64	20	59+59	18	52+52	16	50+50	14	45+45	12	40+40
	Heat	22	71+71	21	71+71	20	59+59	18	52+52	16	48+48	14	40+40
79	Cool	23	74+74	22	69+68	19	67+66	17	58+57	16	50+50	14	36+36
	Heat	24	79+78	23	74+74	22	69+68	19	58+57	17	58+57	15	45+44
85	Cool	23	74+74	22	69+68	19	67+66	17	58+57	16	50+50	14	36+36
	Heat	24	79+78	23	74+74	22	69+68	19	58+57	17	58+57	15	45+44
90	Cool	23	74+74	22	69+68	19	67+66	17	58+57	16	50+50	14	36+36
	Heat	24	79+78	23	74+74	22	69+68	19	58+57	17	58+57	15	45+44

Table 27 Low noise mode (cont.)

ODU (kW)		Silent mode 13		Silent mode 14	
		Max. fan step	Max. freq. step	Max. fan step	Max. freq. step
25	Cool	10	21	10	16
	Heat	10	31	10	23
28	Cool	10	21	10	16
	Heat	10	31	10	23
33	Cool	10	21	10	16
	Heat	10	31	10	23
40	Cool	6	32	3	26
	Heat	9	36	6	29
45	Cool	6	32	3	26
	Heat	9	36	6	29
50	Cool	12	26	11	23
	Heat	12	26	11	23
56	Cool	12	26	11	23
	Heat	12	26	11	23
62	Cool	11	30	10	26
	Heat	12	30	11	26
67	Cool	11	30	10	26
	Heat	12	30	11	26
73	Cool	11	30	10	26
	Heat	12	31	11	26
79	Cool	14	33	14	21
	Heat	15	38	15	24
85	Cool	14	33	14	20
	Heat	15	38	15	24
90	Cool	14	33	14	21
	Heat	15	38	15	24

Table 28 Low noise mode (cont.)

4.8.5 Power limitation mode

The energy saving mode limits the system power. It can be used to limit the line selection current or to reduce the peak current.

Power limitation mode setting	Power limitation mode level	Correction factor
n23 40-n23 100	n23 40	40%
	n23 41	41%
	n23 42	42%
	~	
	n23 98	98%
	n23 99	99%
	n23 100 (default)	100%

Table 29

5 Field settings

5.1 Overview

This chapter describes how the system configuration can be implemented once the installation is completed, and other relevant information.

It contains the following information:

- Implement field settings
- Using the Check function



The installation personnel should read this chapter.

5.2 Digital display and button settings



CAUTION

Risk of electric shock!

Avoid touching of live parts.

- ▶ Operate the switches and push buttons with an insulated stick (such as a closed ball-point pen).

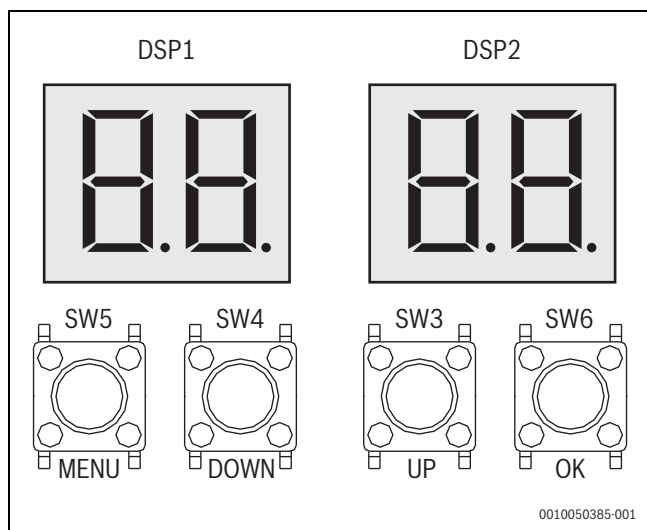

5.2.1 Digital display output

Outdoor unit state		Parameters displayed on DSP1	Parameters displayed on DSP2
Standby		Address of the outdoor unit	The number of indoor units in communication with the outdoor units
Normal operation	For single compressor units	–	Running speed of the compressor in rotations per second
Other operation state		Operation state code	Operation state code
Error or protection		Placeholder and error or protection code	
In menu mode		Display menu mode code	
System check		Display system check code	

Table 30 Digital display output

5.2.2 Function of buttons SW3 to SW6

Button		Function
SW3	UP	In menu mode: previous and next buttons for menu modes. Not in menu mode: previous and next buttons for system check information.
SW4	DOWN	
SW5	MENU	Enter / exit menu mode.
SW6	OK	Confirm to enter specified menu mode.

Table 31

5.2.3 Menu mode

Only the master unit has the full menu functions, slave units only have error codes check and cleaning functions.

1. Long press SW5 “MENU” button for 5 seconds to enter menu mode, and the digital display displays “n0”.
2. Press SW3 / SW4 “UP / DOWN” button to select the first level menu “n1”, “n2”, “n3”, “n4”, “n5”, “n9” or “nc”.
3. Press SW6 “OK” button to enter specified first level menu, for example, enter “n2” mode.
4. Press SW3 / SW4 “UP / DOWN” button to select the second level menu from “n20” to “n28”.
5. Press SW6 “OK” button to enter specified second level menu, for example, enter “n22” mode.
6. Press SW3 / SW4 “UP / DOWN” button to select the specified menu code, for example, from “0” to “6”.
7. Press SW6 “OK” button to enter specified menu mode, for example, enter “2” mode.
8. Press SW5 “MENU” to return to the previous level.
9. Press SW5 “MENU” repeatedly until you exit menu mode.

Menu modes



Default settings are **highlighted**.

MENU	Second level	Description
n0	0	<ul style="list-style-type: none"> • 0 = History error • 1 = Cleaning history error
	1	<ul style="list-style-type: none"> • 0 = Query indoor unit's address • 2 = Query power OFF indoor unit's address
	2	<ul style="list-style-type: none"> • 1 = Driver's version (compressor and fan displayed in turn)
	4	Accumulated running time of compressor
n1	0	Shield C26 and C28 error in 3 hours
	1	<ul style="list-style-type: none"> • 0 = Cooling test • 1 = Heating test • 2 = Test running • 4 = System refrigerant quantity detection
	2	<ul style="list-style-type: none"> • 0 = Refrigerant recovery to outdoor unit • 1 = Refrigerant recovery to indoor unit • 2 = Balance system refrigerant
	3	<ul style="list-style-type: none"> • 0 = Manual refrigerant charge • 1 = Auto refrigerant charge (customized)
	4	Exit special mode (system test; refrigerant recovery; refrigerant charge; vacuum mode)
	5	Vacuum mode
	6	Set VIP indoor unit address (default no. 63)

MENU	Second level	Description
n2	0	Priority mode <ul style="list-style-type: none"> • 0 = Automatic priority mode • 1 = Cooling priority mode • 2 = VIP indoor unit voting priority mode • 3 = In response to heating mode only • 4 = In response to cooling mode only • 5 = Heating priority mode • 6 = Change over • 7 = Voting priority mode • 8 = First on priority mode • 9 = Capability requirements priority mode
	1	Silent mode <ul style="list-style-type: none"> • 0 = Non silent mode • 1...9 = Silent mode 1...9 • A...E = Silent mode 10...14
	2	Static pressure <ul style="list-style-type: none"> • 0 = 0 Pa • 1 = 20 Pa
	3	Power limitation mode <ul style="list-style-type: none"> • 40...100 = Power limitation (in % capacity output)
	4	ECO+ mode <ul style="list-style-type: none"> • 0 = disabled • 1 = activated
	5	Unit for temperature <ul style="list-style-type: none"> • 0 = Celsius • 1 = Fahrenheit
	6	Auto snow-blowing function <ul style="list-style-type: none"> • 0 = Auto snow-blowing function disabled • 1 = Auto snow-blowing function activated, mode 1 • 2 = Auto snow-blowing function activated, mode 2
	7	Auto dust-clean function <ul style="list-style-type: none"> • 0 = Auto dust-clean function disabled • 1 = Auto dust-clean function activated
	8	Dry contact <ul style="list-style-type: none"> • 0 = OFF • 1 = ON
9	Automatic priority mode <ul style="list-style-type: none"> • 0 = Mode switching temperature: 10 °C • 1 = Mode switching temperature: 16 °C • 2 = Mode switching temperature: 21 °C 	

MENU	Second level	Description	
n3	2	Level difference between indoor unit and outdoor unit <ul style="list-style-type: none"> • 0 = 0 m • 1 = 20 m • 2 = 40 m • 3 = 60 m • 4 = 80 m • 5 = 100 m • 6 = 110 m 	
	4	<ul style="list-style-type: none"> • 0 = Normal • 1 = High sensible heat mode • 2 = Low temperature mode 	
	7	Ambient temperature sensor <ul style="list-style-type: none"> • 0 = Internal (T4) • 1 = External (T10-Optional) 	
	8	Chassis electric heating <ul style="list-style-type: none"> • 0 = Function disabled • 1 = Function activated (customized) 	
	9	PTC heating in E-box <ul style="list-style-type: none"> • 0 = Function disabled • 1 = Function activated (customized) 	
	n4	0	Outdoor unit address
		1	Network address (0)
		2	Number of indoor units (1)
		4	<ul style="list-style-type: none"> • 0 = Auto addressing (indoor and outdoor units) • 1 = Clear address (indoor and outdoor units, network address)
5		Communication type <ul style="list-style-type: none"> • 2 = SuperLink (M1 M2) with uniform power supply • 3 = SuperLink (M1 M2) with separate power supply 	
n5	0	Fan, compressor and outdoor unit backup <ul style="list-style-type: none"> • 0 = disabled • 1 = activated 	
	1	Sensor backup running <ul style="list-style-type: none"> • 0 = disabled • 1 = activated (manual) • 2 = activated (automatic) 	
	2	Backup operation time <ul style="list-style-type: none"> • 0...6 = 1...7 days 	

MENU	Second level	Description
n6	0	Target evaporation temperature of the indoor unit <ul style="list-style-type: none"> • 0 = -3 °C • 1 = 0 °C • 2 = 3 °C • 3 = 6 °C • 4 = 7 °C • 5 = 8 °C • 6 = 9 °C • 7 = 10 °C • 8 = 11 °C
	2	Target condensation temperature of the indoor unit <ul style="list-style-type: none"> • 0 = 41 °C • 1 = 42 °C • 2 = 43 °C • 3 = 44 °C • 4 = 45 °C • 5 = 46 °C • 6 = 48 °C • 7 = 51 °C
n8	7	Low noise defrosting <ul style="list-style-type: none"> • 0 = Mode disabled • 1 = Mode activated
n9	1	Rotation <ul style="list-style-type: none"> • 0 = Function disabled • 1 = Compressor rotation function activated • 2 = Outdoor unit rotation function activated • 3 = Compressor + outdoor unit rotation function activated
	5	Release central controller emergency stop
	7	Electricity meter type <ul style="list-style-type: none"> • 0 = Digital • 1 = Pulse
nc	0	Dry contact 1 function selection <ul style="list-style-type: none"> • 0 = Force cooling only • 1 = Force heating only • 2 = Force incapacity requirements • 3 = Force stop
	1	Dry contact 2 function selection <ul style="list-style-type: none"> • 0 = Force cooling only • 1 = Force heating only • 2 = Force incapacity requirements • 3 = Force stop
	2	Dry contact 3 function selection (customized) <ul style="list-style-type: none"> • 0 = Operation signal • 1 = Alarm signal • 2 = Compressor running signal • 3 = Defrosting signal • 4 = Refrigerant leakage signal

Table 32 Menu modes available on main PCB

5.3 Modes set on main PCB

5.3.1 Priority mode setting

Priority mode can only be set on the outdoor unit. When an indoor unit is in mode conflict with the outdoor units the unit displays the mode conflict error. The digital display on indoor main PCB will display error code E0.

There are 10 priority mode options:

- Auto priority mode (default)
- Cooling priority mode
- Heating priority mode
- VIP priority mode
- Changeover mode
- Voting priority mode
- First on priority mode
- Capability requirements priority mode
- Heating only mode
- Cooling only mode

Auto priority mode (default)

In auto priority mode, the outdoor unit will operate in heating priority mode or cooling priority mode according to the outdoor ambient temperature.

In this function, the mode switching temperature is **A**, and A can be set by menu [n2-9-0/1/2].

- When the outdoor ambient temperature is below (A-3) °C, the outdoor units run in heating priority mode. The heating priority mode does not change until the outdoor ambient temperature is above A °C.
- When the outdoor ambient temperature is above A °C, the outdoor units run in cooling priority mode. The cooling priority mode does not change until the outdoor ambient temperature is below (A-3) °C.
- When the outdoor units restart under the outdoor ambient between (A-3) °C and A °C, the outdoor units run the same priority as before the last stop.
- On initial startup with outdoor unit ambient temperature between (A-3) °C and A °C, the outdoor units run in heating priority mode.

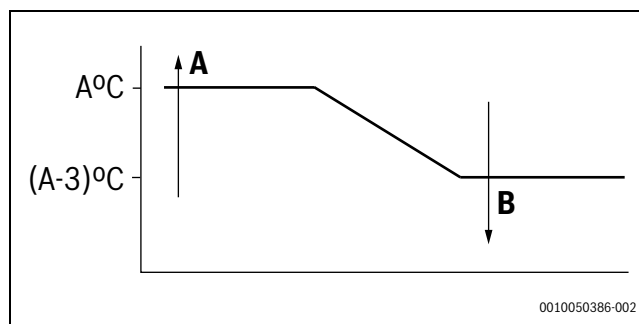

A Cooling priority

B Heating priority

Cooling priority mode

- During heating operation:
 - If an indoor unit requests cooling, the outdoor units stop and then restart in cooling mode after 5 minutes. Indoor units requesting cooling then start in cooling mode and indoor units requesting heating display the mode conflict error.
- During cooling operation:
 - If an indoor unit requests heating, the outdoor units ignore the request and continue to run in cooling mode. The indoor unit requesting heating displays the mode conflict error. If all the indoor units requesting cooling are later turned off and one or more indoor units are still requesting heating, the outdoor units restart in heating mode after 5 minutes and any indoor units requesting heating then start in heating mode.

Heating priority mode

- During heating operation:
 - If an indoor unit requests cooling, the outdoor units ignore the request and continue to run in heating mode. The indoor unit requesting cooling displays the mode conflict error. If all the indoor units requesting heating are later turned off and one or more indoor units are still requesting cooling, the outdoor units restart in cooling mode after 5 minutes and any indoor units requesting cooling then start in cooling mode.
- During cooling operation:
 - If an indoor unit requests heating, the outdoor units stop and then restart in heating mode after 5 minutes. Indoor units requesting heating then start in heating mode and indoor units requesting cooling display the mode conflict error.

VIP priority mode

The default VIP address is 63, the VIP address also can be changed through menu mode“n1-6”.

In VIP priority mode, if the VIP indoor unit is operating, the outdoor units will operate in the mode of the VIP indoor unit. In the meantime indoor units, which are in a mode different to that of the VIP unit, will display the mode conflict error (E0).

Changeover mode

The VIP indoor unit address must be set before using this mode. The default VIP address is 63, the VIP address can also be changed through menu mode“n1-6”.

In changeover mode, if the VIP indoor unit is operating, the outdoor units will operate in the mode of the VIP indoor unit. The other units in the system will follow the mode of the VIP indoor unit, so there will be no mode conflict.

In changeover mode, the VIP indoor unit can select the auto mode, so that the system can run the auto mode, and other indoor units can follow the VIP indoor unit without mode conflict.

Voting priority mode

In voting priority mode, the outdoor units operate in whichever of heating and cooling modes is being requested by the larger number of indoor units.

First on priority mode

The outdoor units will operate in the mode of the first open indoor unit in the system. At the same time, indoor units which are in a mode different to that of the first open unit, will display the mode conflict error (E0).

Capability requirements priority mode

In capability requirements priority mode, the outdoor units operate in whichever of heating and cooling modes is being requested by the larger capability requirements of indoor units.

Heating only mode

The outdoor units only operate in heating mode. Indoor units requesting heating operate in heating mode. Indoor units requesting cooling or in fan only mode display the mode conflict error.

Cooling only mode

The outdoor units only operate in cooling mode. Indoor units requesting cooling operate in cooling mode; indoor units in fan only mode operate in fan only mode. Indoor units requesting heating display the mode conflict error.

5.3.2 System test**Cooling and heating test**

After the outdoor unit enters this mode, all indoor units in the system are forced to run cooling or heating mode, which is consistent with the normal operation.

How to exit test:

- Press and hold the OK key for 5s to exit.
- Automatic exit in case of failure during operation
- Automatic exit after 240 minutes of test.

Test running

This operation checks and determines the following items:

- Check if there is a wiring error (with the communication check of the indoor unit).

- Check if the stop valve is open.
- Determine the length of the pipe.

There are 8 steps in the test running, and the process is as follows:

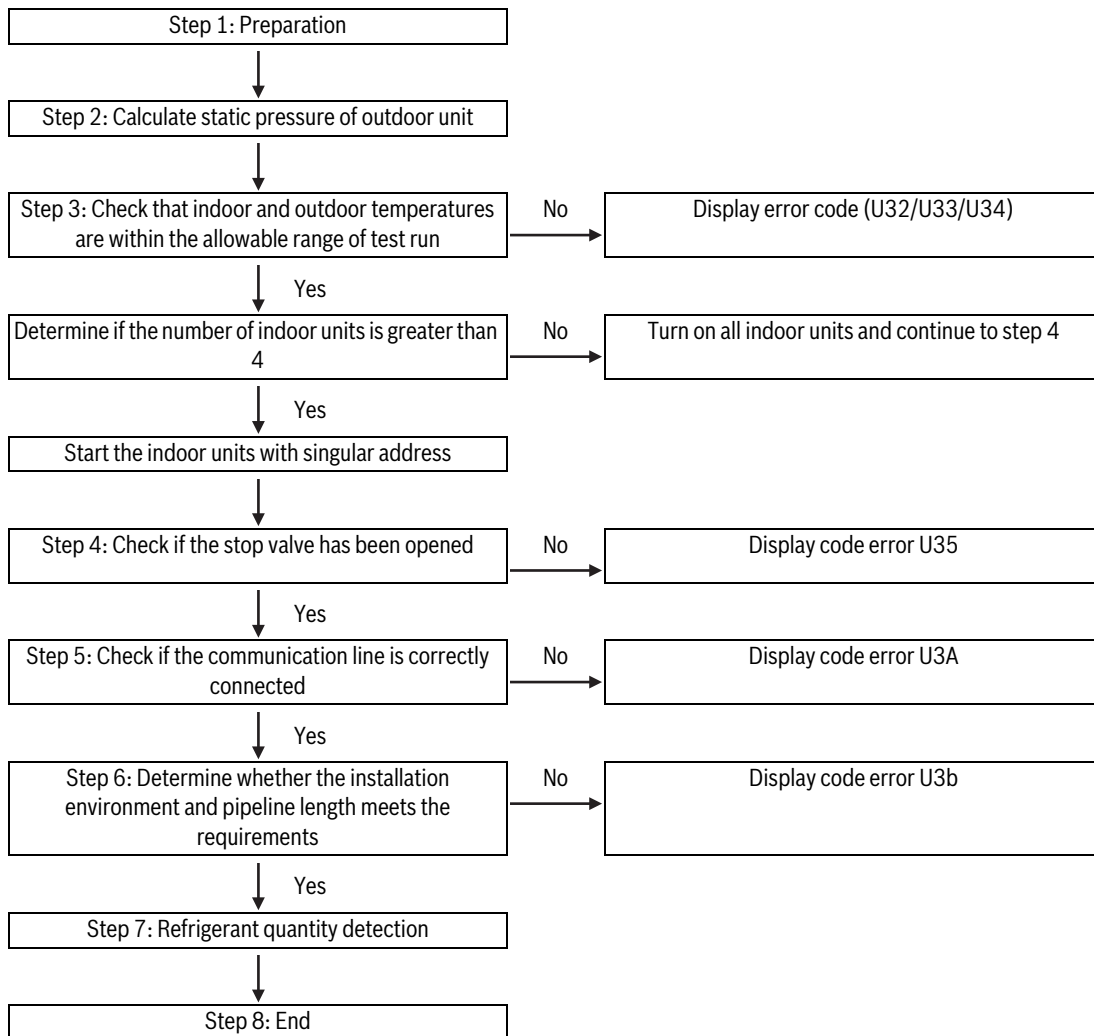

System refrigerant quantity detection

After entering this mode, the system will automatically run and output the diagnostic results of the system refrigerant quantity.

Diagnostic results:

- Normal: Digital display “d34”
- Significantly excessive: Digital display “d32”
- Excessive: Digital display “d33”
- Insufficient: Digital display “d35”
- Significantly insufficient: Digital display “d36”
- No result - The system operation conditions do not meet the functional requirements: Digital display “d31”

5.3.3 Refrigerant recovery

In this mode, the operation process is as follows:

Refrigerant recovery to outdoor unit

1. Close the liquid pipe stop valve and keep the gas pipe stop valve open.
2. Select menu setting [n1-2-0] for the system to enter the refrigerant recovery mode.
3. Close the gas pipe stop valve when the digital display displays "End" and the system low pressure value alternately.

Refrigerant recovery to indoor unit

1. Close the liquid pipe stop valve and keep the gas pipe stop valve open.

2. Select menu setting [n1-2-1] for the system to enter the refrigerant recovery mode.
3. Close the gas pipe stop valve when the digital display displays "End" and the system low pressure value alternately.

Balance system refrigerant

1. Ensure that both the gas pipe stop valve and the liquid pipe stop valve are open.
2. Select menu setting [n1-2-2] for the system to enter the balance system refrigerant mode.

5.3.4 Refrigerant charge

Manual refrigerant charge

Without customized refrigerant charging valve (EEVE)

Charge the refrigerant through the stop valve.

With customized refrigerant charging valve (EEVE)

1. Select menu setting [n1-3-0] for refrigerant charging valve (EEVE) to open.
2. Charge the refrigerant through EEVE.

Auto refrigerant charge

The refrigerant charging valve (EEVE) must be customized to use this function.

Menu setting [n1-3-1], refrigerant charging valve (EEVE) will open, the system will automatically charge refrigerant through EEVE. When

refrigerant charging is completed, the digital displays “End” and EEVE will close.

5.4 System parameter check

UP / DOWN system check button

Before pressing “UP” or “DOWN” button, allow the system to operate steadily for more than one hour. On pressing “UP” or “DOWN” button, the parameters listed in below table will be displayed in sequence.

DSP1 content	Parameters displayed on DSP2	Remarks
-	“Standby (outdoor unit address + indoor unit quantity)/frequency/special status”	-
0	Unit address	Outdoor unit: 0; slave units: 1, 2; 255 represents invalid address
1	Unit capacity	Actual value = Display value (HP)
2	Number of outdoor units	1...4 (only available for the master unit [combined system])
3	Number of indoor units (set by the master unit)	1...64 (only available for the master unit [combined system])
4	Total capacity of outdoor unit	Only available for the master unit (only available for the master unit [combined system]; 0 displayed on slave units has no meaning)
5	Target frequency of this outdoor unit	Displacement frequency; To be converted to current compressor output volume. Example: • Compressor output volume = 70 • Target frequency = Actual frequency × 70 / 60
6	Target frequency of outdoor unit system	Displacement frequency = Display value × 10
7	Actual frequency of inverter compressor A [Hz]	Actual value = Display value
8	Actual frequency of inverter compressor B [Hz]	Actual value = Display value
9	Operating mode	Operation mode: 0 (OFF); 2 (cooling); 3 (heating); 5 (main cooling); 6 (main heating) Modes 5 and 6 are only available for heat recovery units
10	Fan speed A [RPM]	Actual value = Display value
11	Fan speed B [RPM]	Actual value = Display value
12	Indoor heat exchanger pipe average temperature (T2) [°C]	Actual value = Display value (only available for the master unit [combined system])
13	Indoor heat exchanger pipe average temperature (T2B) [°C]	Actual value = Display value (only available for the master unit [combined system])
14	Main heat exchanger pipe temperature (T3) [°C]	Actual value = Display value
15	Outdoor ambient temperature (T4) [°C]	Actual value = Display value
16	Liquid stop valve inlet temperature (T5) [°C]	Actual value = Display value
17	Micro-channel heat exchanger inlet temperature (T6A) [°C]	Actual value = Display value
18	Micro-channel heat exchanger outlet temperature (T6B) [°C]	Actual value = Display value
19	Inverter compressor A discharge temperature (T7C1) [°C]	Actual value = Display value
20	Inverter compressor B discharge temperature (T7C2) [°C]	Actual value = Display value
21	Inverter compressor A suction temperature (T71) [°C]	Actual value = Display value
22	Inverter compressor B suction temperature (T72) [°C]	Actual value = Display value
23	Condenser inlet temperature (T8) [°C]	Actual value = Display value
24	Inverter module heatsink (Ntc) [°C]	Actual value = Display value
25	Heat recovery unit temperature (Reserved) (T9) [°C]	Actual value = Display value
26	Outdoor heat exchanger liquid temperature (TL) [°C]	Actual value = Display value
27	Discharge superheat degree [°C]	Actual value = Display value
28	Primary current [A]	Actual value = Display value /10
29	Inverter compressor A current [A]	Actual value = Display value /10
30	Inverter compressor B current [A]	Actual value = Display value /10
31	EEVA position	Actual value = Display value × 24
32	EEVB position	Actual value = Display value × 24

DSP1 content	Parameters displayed on DSP2	Remarks
33	EEVC position	Actual value = Display value × 4
34	EEVD position	Actual value = Display value × 4
35	Compressor discharge pressure [MPa]	Actual value = Display value × 0.01
36	Compressor suction pressure [MPa]	Actual value = Display value × 0.01
37	Number of indoor units online	Actual value = Display value (only available for the master unit [combined system])
38	Number of indoor units currently operating	Actual value = Display value (only available for the master unit [combined system])
39	Heat exchanger status	0 (OFF); 1/C1 (cooling mode); 2/D1 (cooling mode disabled); 3/D2 (cooling mode compressor OFF) ¹⁾ ; 4/E1 (heating mode); 5/F1 (heating mode disabled); 6/F2 (heating mode compressor OFF) ¹⁾
40	Special mode	0 (OFF); 1 (oil return); 2 (defrost); 3 (start-up); 4 (stop); 5 (quick check); 6 (self cleaning)
41	Silent mode	0...14; 14 represents the most silent mode
42	Static pressure mode	0: 0 Pa; 1: 20 Pa; 2: 40 Pa; 3: 60 Pa; 4: 80 Pa; 5: 100 Pa; 6: 120 Pa
43	Target evaporating temperature (T _{es}) [°C]	Actual value = Display value ²⁾
44	Target condensing temperature (T _{cs}) [°C]	Actual value = Display value ³⁾
45	DC voltage [V]	Actual value = Display value
46	AC voltage [V]	Actual value = Display value
47	Quantity of indoor units in cooling mode	Actual value = Display value
48	Quantity of indoor units in heating mode	Actual value = Display value
49	Capacity of indoor units in cooling mode (HP)	Actual value = Display value (only available for the master unit [combined system])
50	Capacity of indoor units in heating mode	Actual value = Display value (only available for the master unit [combined system])
51	Refrigerant volume	0 (no result); 1 (significantly insufficient); 2 (insufficient); 3 (normal); 4 (excessive); 5 (significantly excessive)
52	Dirty blockage rate	0...10; 10 represents the worst
53	Fan historical error	
54	Software version	
55	Last error or protection code	
56	Reserved	
57	Reserved	
58	Reserved	

1) Only available for heat recovery unit

2) T_e: Low pressure equivalent saturation temperature (°C) T_{es}: Target T_e value.

3) T_c: Low pressure equivalent saturation temperature (°C) T_{cs}: Target T_c value.

Table 33

6 Electrical components and wiring diagrams

6.1 Outdoor unit electric control box layout

25-45kW

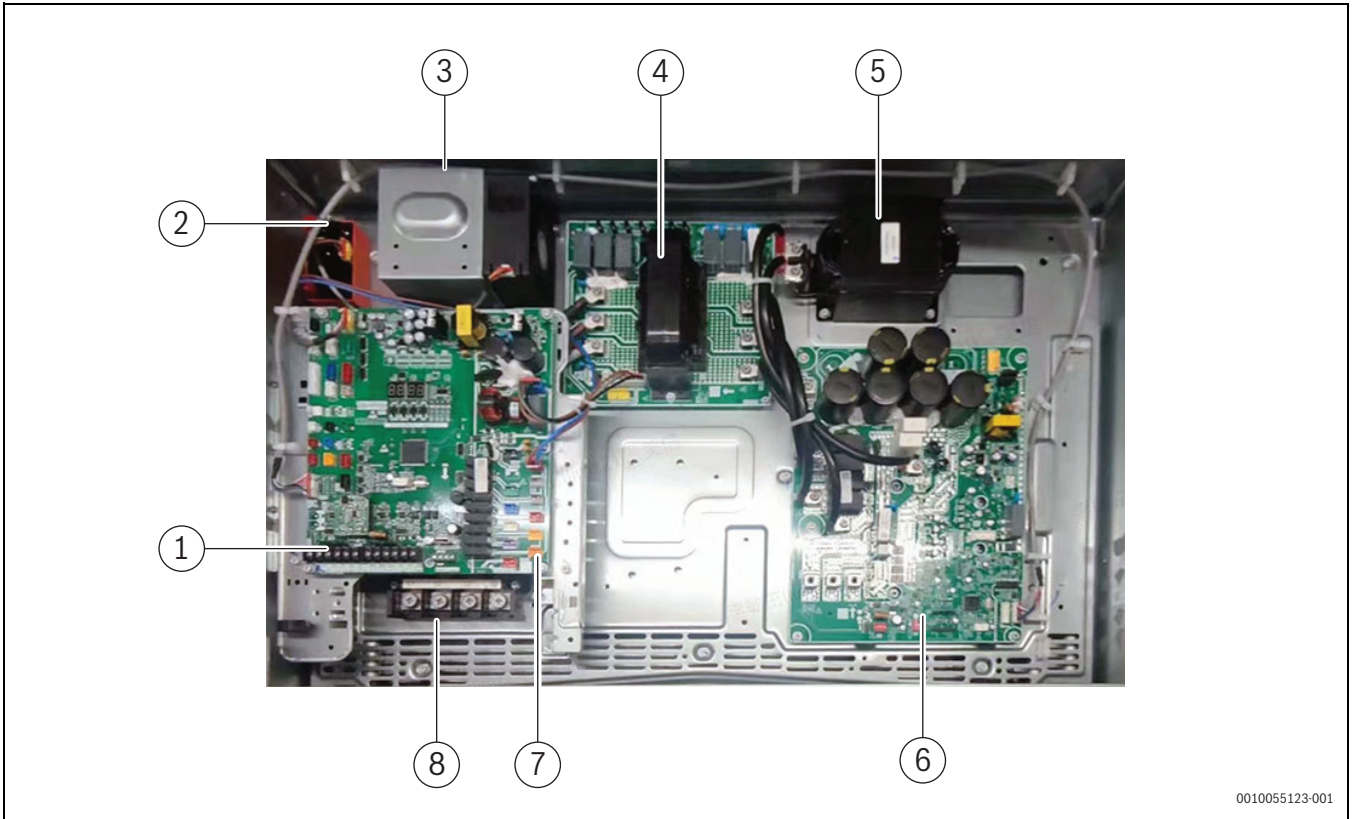

0010055123-001

Fig. 33 25-45kW electric control box

- [1] Communication terminals block
- [2] Power supply of the recirculation fan
- [3] Recirculation fan
- [4] Filter board
- [5] Reactor
- [6] Compressor and fan drive board
- [7] Main control board
- [8] Power supply terminals

54-67kW

Fig. 34 54-67kW electric control box

- [1] Communication terminals block
- [2] Power supply of the recirculation fan
- [3] Recirculation fan
- [4] Filter board
- [5] Reactor
- [6] Fan drive board
- [7] Compressor board
- [8] Main control board
- [9] Power supply terminals

73-90kW

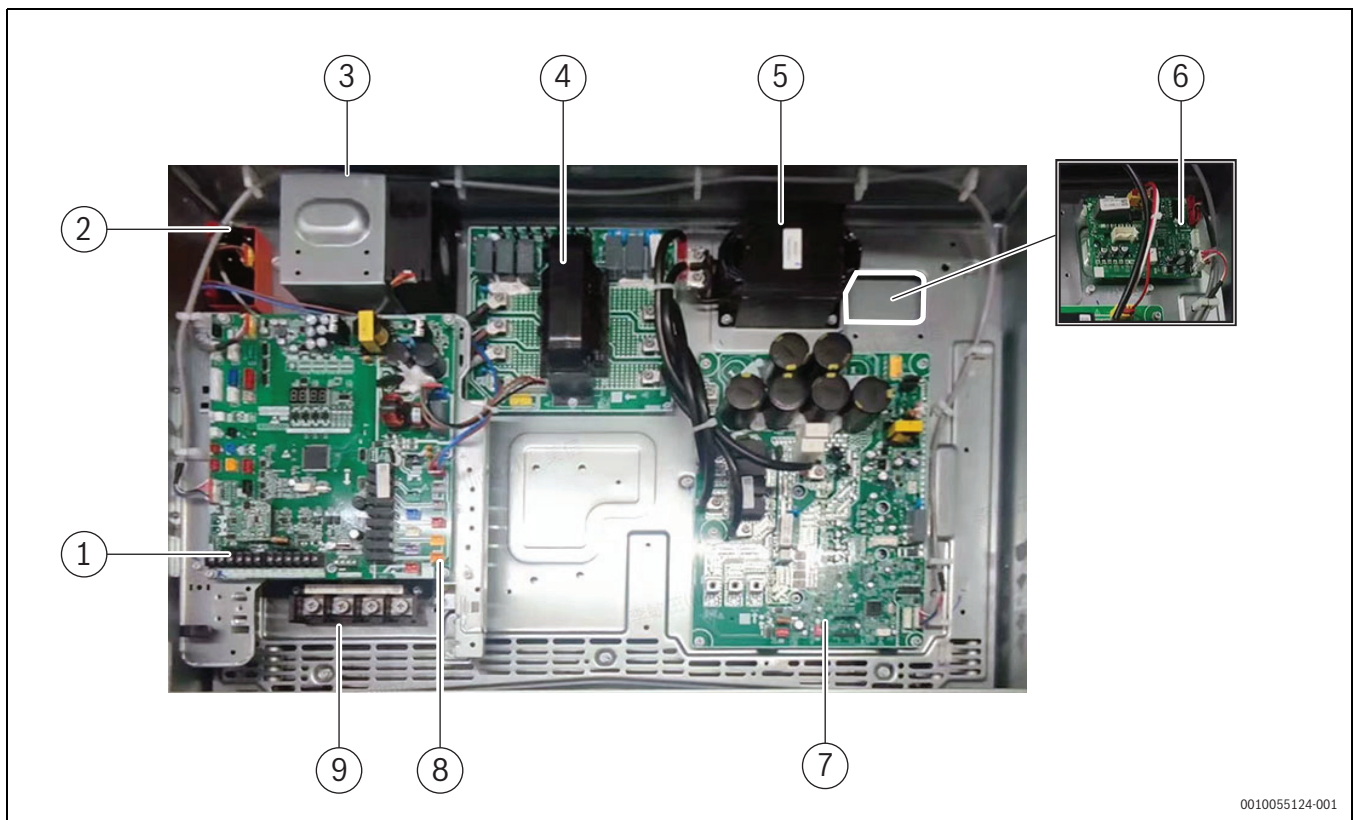
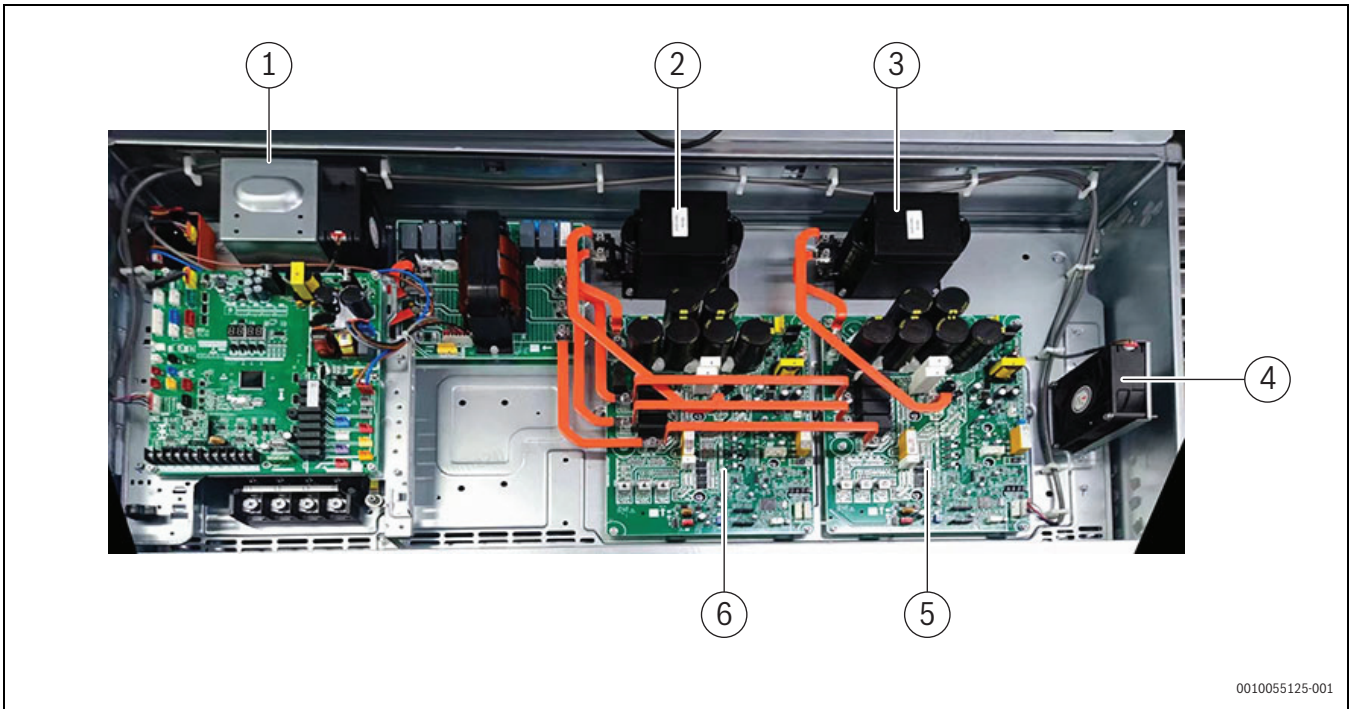

0010055125-001

Fig. 35 73-90kW electric control box

- [1] Recirculation fan A
- [2] Reactor A
- [3] Reactor B
- [4] Recirculation fan B
- [5] Compressor and fan drive board B
- [6] Compressor and fan drive board A

6.2 Outdoor unit main PCB

6.2.1 Ports

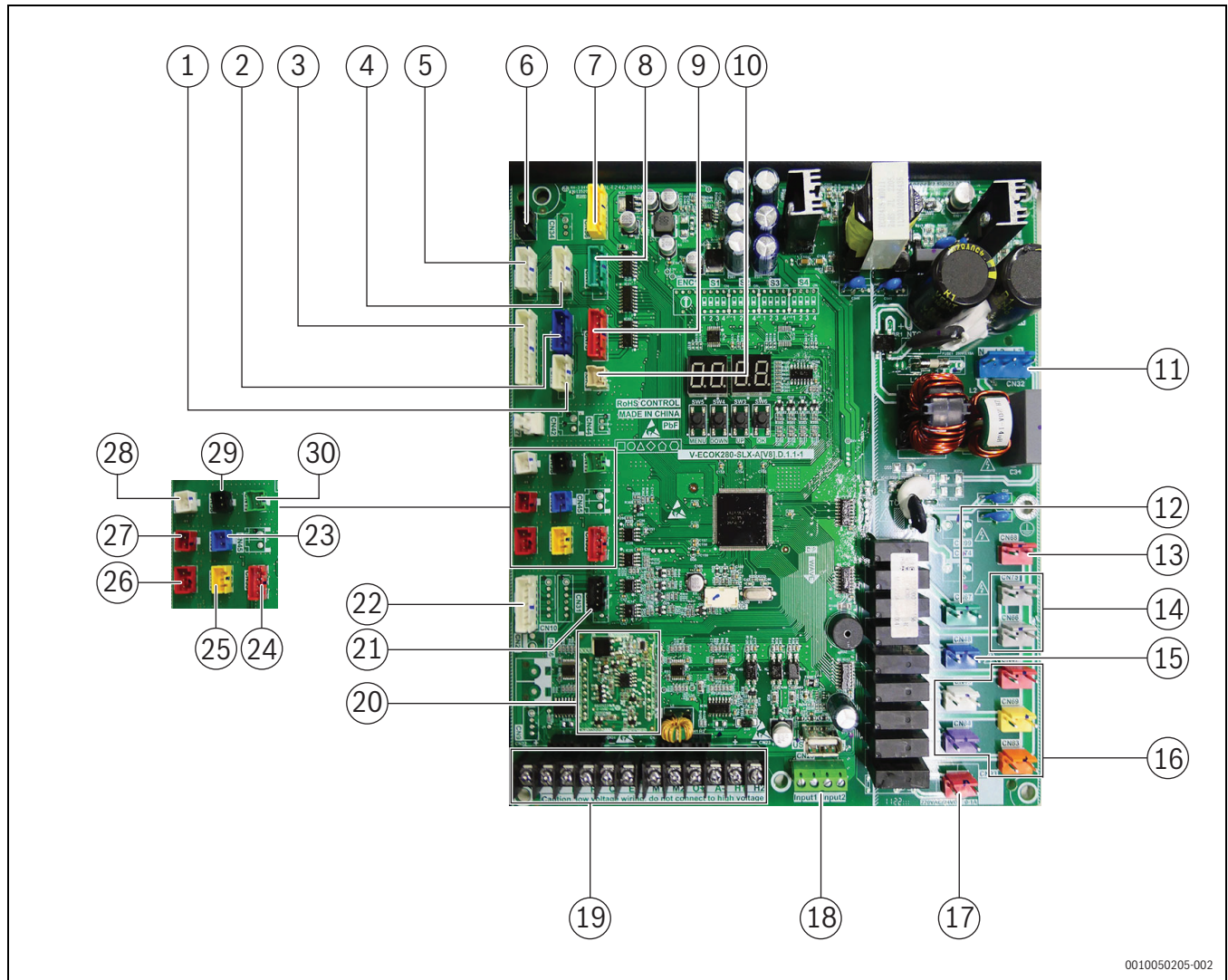

0010050205-002

Fig. 36 Outdoor unit main PCB ports

Label in Fig. 36	Port code	Content	Port voltage
1	CN8	Condenser inlet temperature sensor (T8) Main exchanger pipe temperature sensor (T3)	3.3V DC
2	CN35	Reserved	3.3V DC
3	CN4	Micro-channel heat exchanger inlet temperature sensor (T6A) Liquid pipe inlet temperature sensor (T5) Micro-channel heat exchanger outlet temperature sensor (T6B) Suction temperature sensor 1 (T71) Discharge temperature sensor 1 (T7C1)	3.3V DC
4	CN71	Reserved; EEVB drive port	12V DC
5	CN70	EEVA drive port	12V DC
6	CN82	Reserved	5V DC
7	CN36	Recirculation fan control port	3.3V DC
8	CN72	EEVC drive port	12V DC
9	CN73	EEVE drive port	12V DC
10	CN3	Condenser outlet temperature sensor (TL)	3.3V DC
11	CN32	Power input of the main board	176V AC - 264V AC
12	CN67	Reserved; Solenoid valve drive ports CN67-SV4	176V AC - 264V AC
13	CN68	Recirculation fan power	176V AC - 264V AC
14	CN75/CN66	Power supply to the compressor crankcase heater	176V AC - 264V AC

Label in Fig. 36	Port code	Content	Port voltage
15	CN48	Four-way valve drive ports (ST1)	176V AC - 264V AC
16	CN47 / CN49 / CN69 / CN84 / CN83	Solenoid valve drive ports CN47-SV6; CN49-SV5; CN69-SV7; CN8-SV8A; CN83-SV8B	176V AC - 264V AC
17	CN93	Dry contact output	0V or Open
18	CN28	Emergency stop port	0V or Open
19	CN22/CN23	Communication port	0-5V DC (varies)
20	-	SuperLink board	-
21	CN14	Communication port to data transfer module	12V DC
22	CN26	Communication port to the compressor and fan drive board	5V DC + 12V DC
23	CN30	Outdoor ambient temperature sensor (T4)	3.3V DC
24	CN33	Expanded communication port	12V DC
25	CN40	High pressure sensor	5V DC
26	CN41	Low pressure sensor	5V DC
27	CN37	Suction temperature sensor 2 (T72)	3.3V DC
28	CN16	Gas pipe temperature sensor (Tg)	3.3V DC
29	CN38	Discharge temperature sensor 2 (T7C2)	3.3V DC
30	CN11	Electric control box chamber temperature sensor (Tb)	3.3V DC

Table 34 Main PCB ports

6.2.2 Components

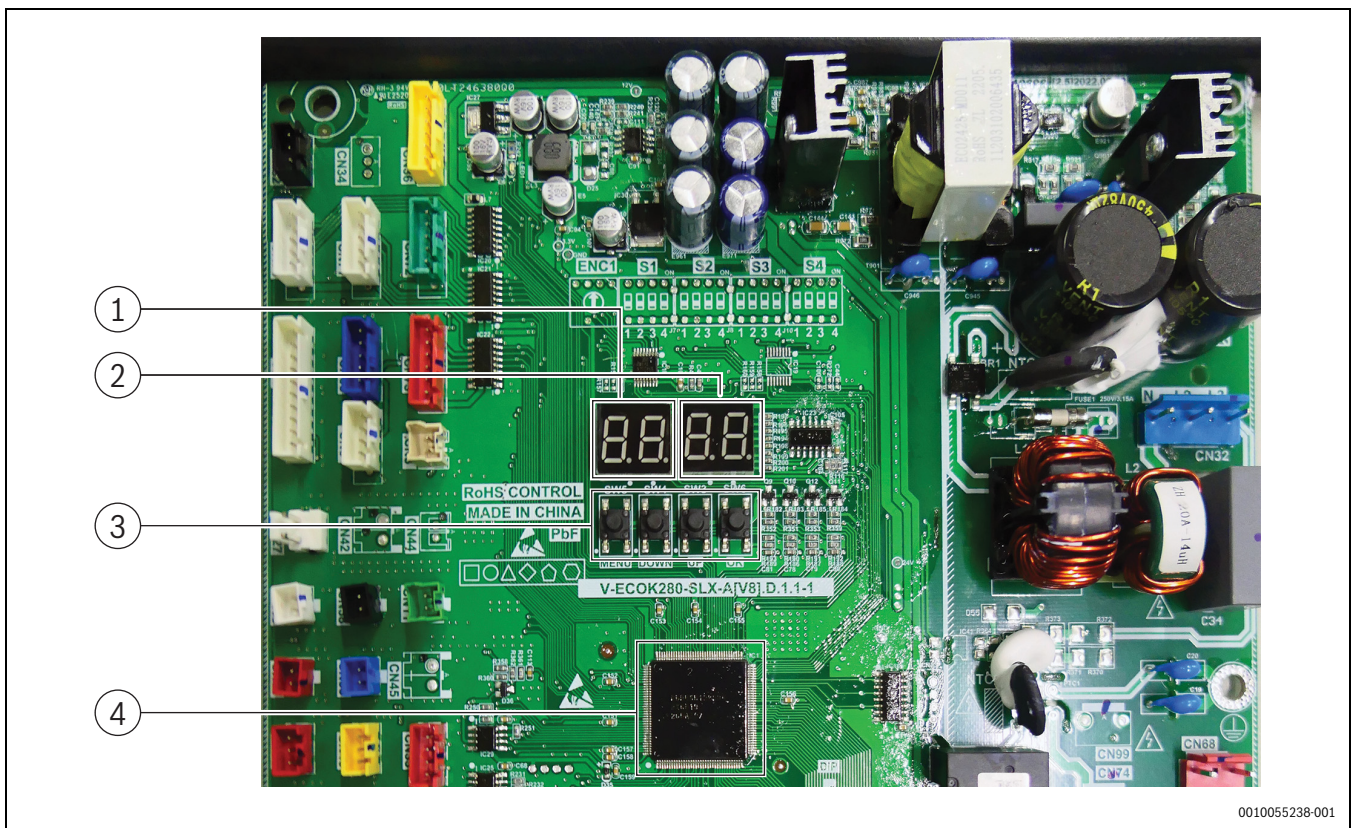

001005238-001

Fig. 37 Control board components

- [1] Digital display DSP1
- [2] Digital display DSP2
- [3] Buttons
- [4] Main control chip

Digital display output

Outdoor unit state		Parameters displayed on DSP1	Parameters displayed on DSP2
Standby		Outdoor unit's address	The number of indoor units in communication with the outdoor units
Normal operation	For single compressor units	–	Running speed of the compressor in rotations per second
Other operation state		Operation state code	Operation state step
Error or protection		Place-holder Error or protection code	
In menu mode		Display menu mode code	
System check		Display system check code	

Table 35

Function of buttons SW3 to SW6

Button		Function
SW3	UP	In menu mode: previous and next buttons for menu modes. Not in menu mode: previous and next buttons for system check information.
SW4	DOWN	
SW5	MENU	Enter / exit menu mode.
SW6	OK	Confirm to enter specified menu mode.

Table 36

6.3 Compressor and fan drive board

6.3.1 Corresponding table of compressor and fan drive board and outdoor units

Compressor and fan drive board model	Model
35A	25-33kW; 73-90kW
50A	45-50 kW
75A	50-67kW; 79-90kW

Table 37 Corresponding table of compressor and fan drive board and outdoor units

6.3.2 Compressor and fan drive board of 35A

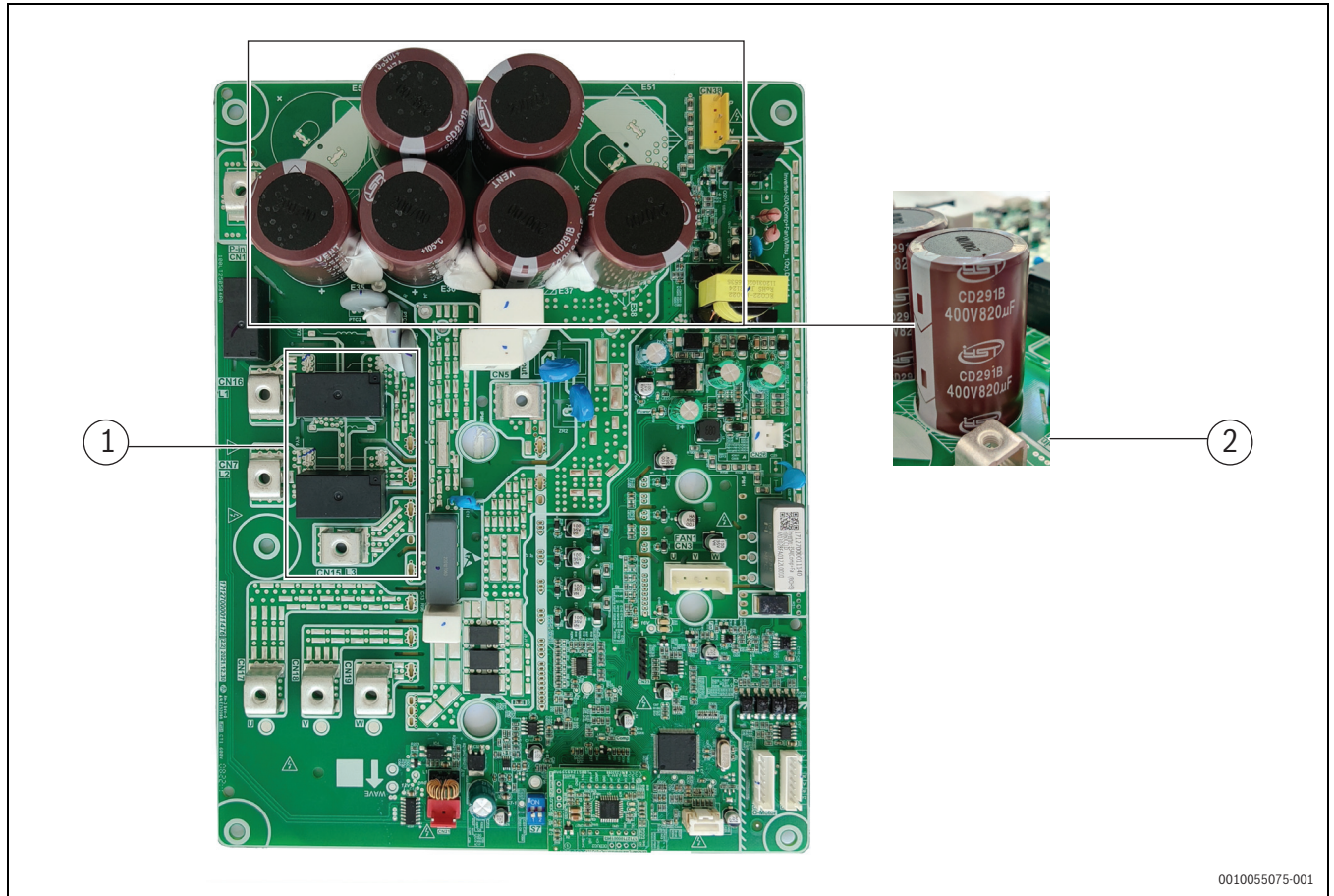

Fig. 38 Compressor and fan drive board of 35A

- [1] Two relays
- [2] Six capacitors of 820µF

6.3.3 Compressor and fan drive board of 50A

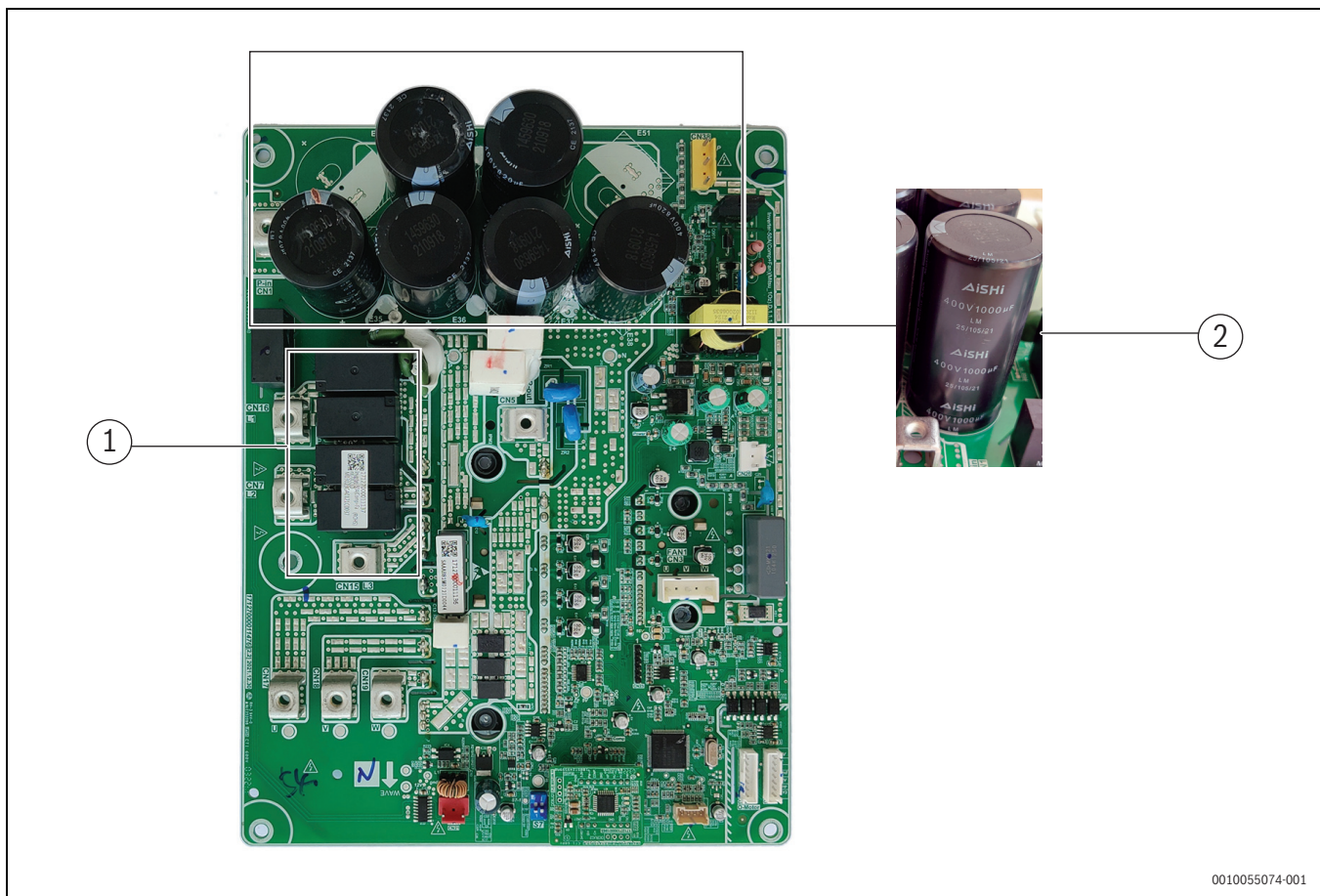
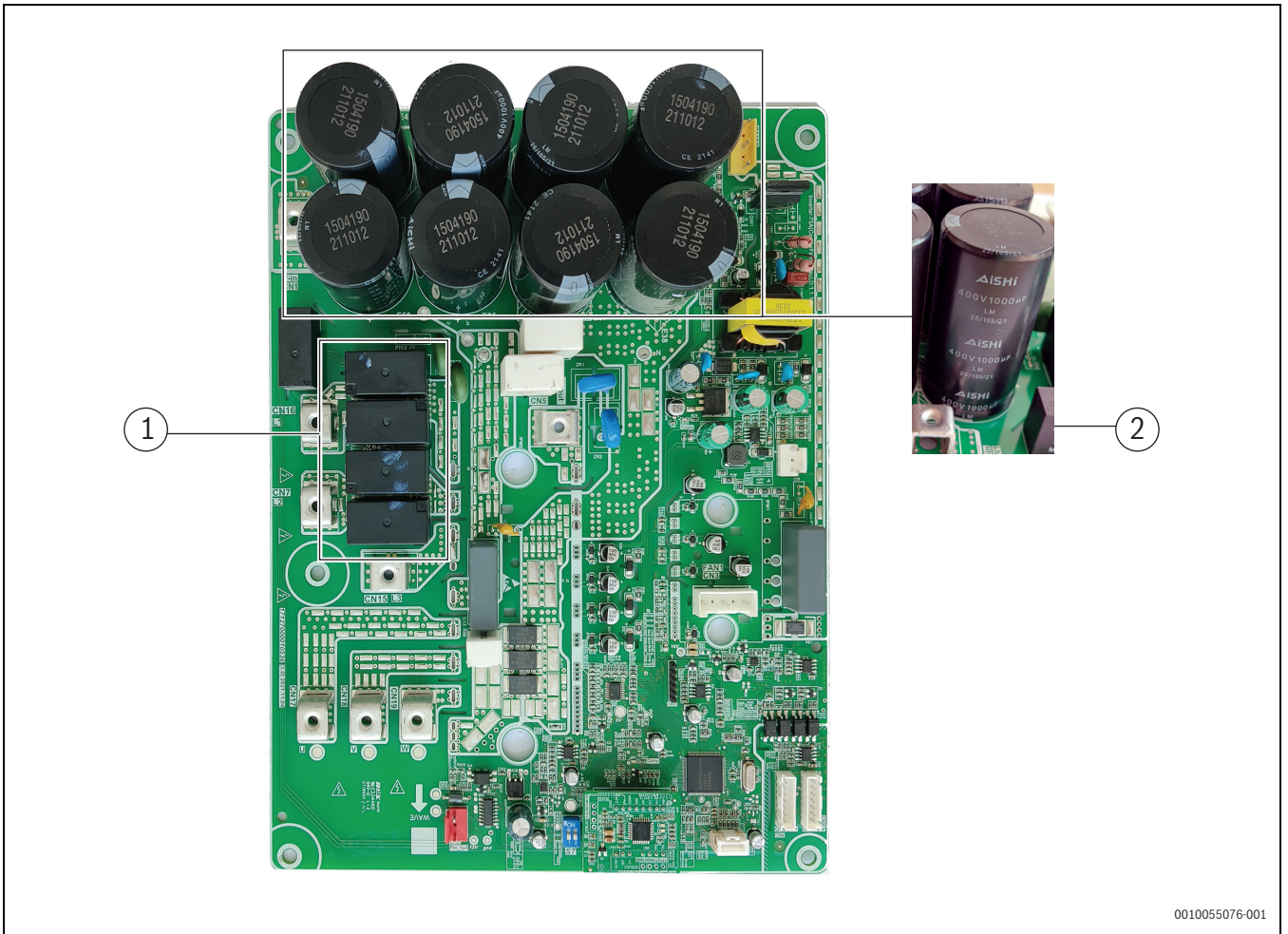

Fig. 39 Compressor and fan drive board of 50A

- [1] Four relays
- [2] Six capacitors of 1000µF

6.3.4 Compressor and fan drive board of 75A



0010055076-001

Fig. 40 Compressor and fan drive of 75A

- [1] Four relays
- [2] Eight capacitors of 1000µF

6.3.5 Compressor and fan drive board ports

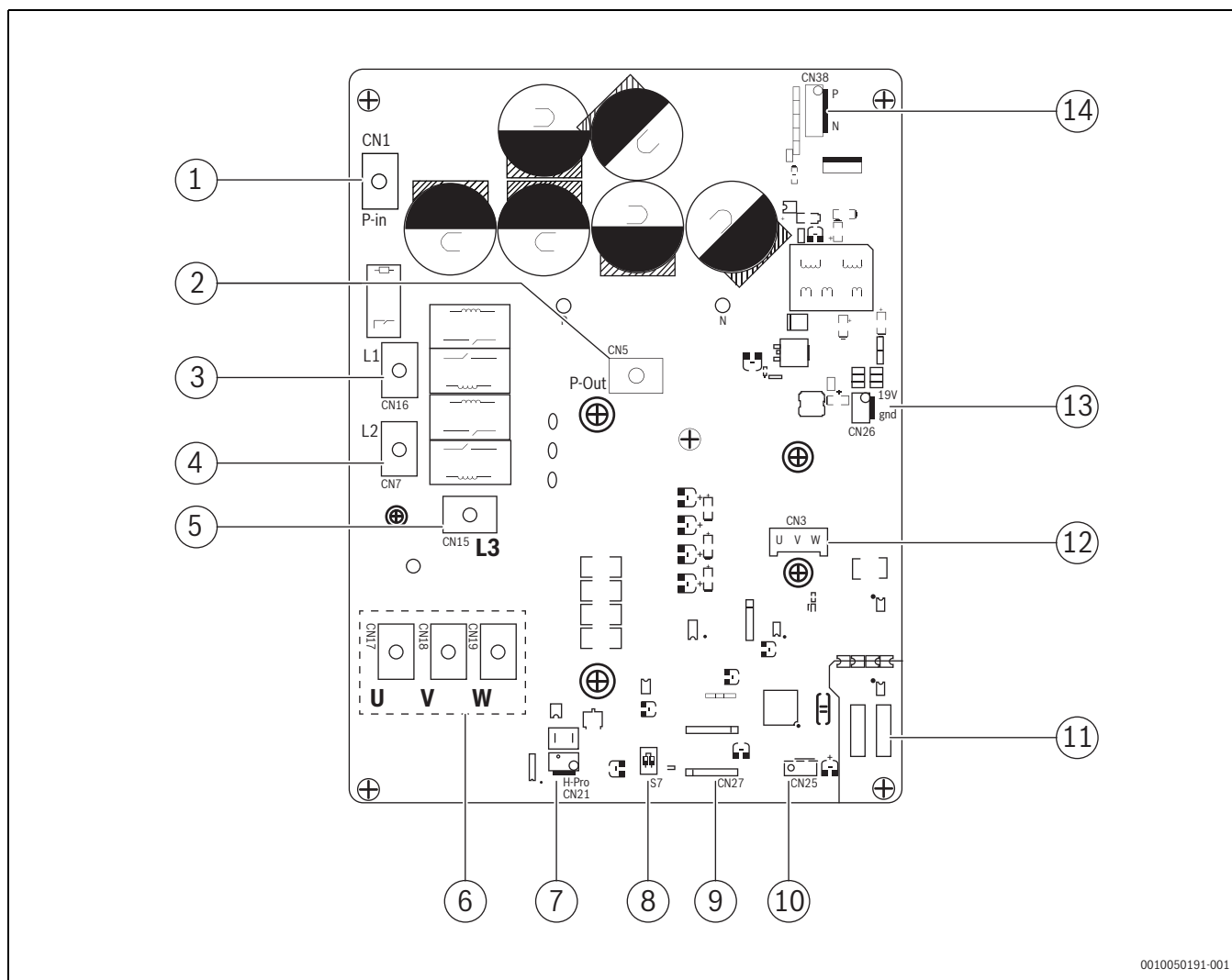

0010050191-001

Fig. 41 Compressor and fan drive board ports

[1] Four relays

Label in figure 41	Port code	Feature identifier	Content	Port voltage
1	CN1	P-in	Positive pole input terminal of the high voltage capacitors (connected to reactor)	438V DC-650V DC (Rated at 540V DC)
2	CN5	P-out	Positive pole output terminal of the three-phase rectifier (connected to reactor)	438V DC-650V DC (Rated at 540V DC)
3	CN16	L1	Three phase power input of L1 phase	310V AC-460V AC (Rated 380V AC between phases)
4	CN7	L2	Three phase power input of L2 phase	310V AC-460V AC (Rated 380V AC between phases)
5	CN15	L3	Three phase power input of L3 phase	310V AC-460V AC (Rated 380V AC between phases)
6	CN3	DCFAN	Three phase output of the inverter, connected to the DC fan	0-100%*input voltage (varying)
7	CN8/CN9	O-Motor	Communication port between main control board and inverter drive board	Ports from top to bottom are defined as follows: 5V, +, -, GND, 12V, empty, and Ry2
8	CN25	-	Debug port	-
9	CN27	-	PED Diagnostic Module	-
10	S7	-	Dial switches of address setting (compressor and fan drive module)	-
11	CN21	H-Pro	High pressure switch connection	Close: 0 V DC Open: 6 V DC

Label in figure 41	Port code	Feature identifier	Content	Port voltage
12	CN17/18/19	U/V/W	Three phase output of the inverter, connected to the compressor	0-100%*input voltage (varying)
13	CN26	-	Reserved; Fan module controls power supply	19V
14	CN38	-	Reserved; Power supply terminal for the DC fan drive board (P,N)	438V DC-650V DC (Rated 540V DC; P is positive, N is negative)

Table 38 Compressor and fan drive board port

 The compressor and fan drive board ports of 35A and 75A are the same as 50A.



Switch	Setting	Switch positions 1	Description
 0010050192-001	Serial number		Fan A
			Fan B

Table 39 Compressor and fan drive board switch settings

6.3.6 Compressor and fan drive board installation guide

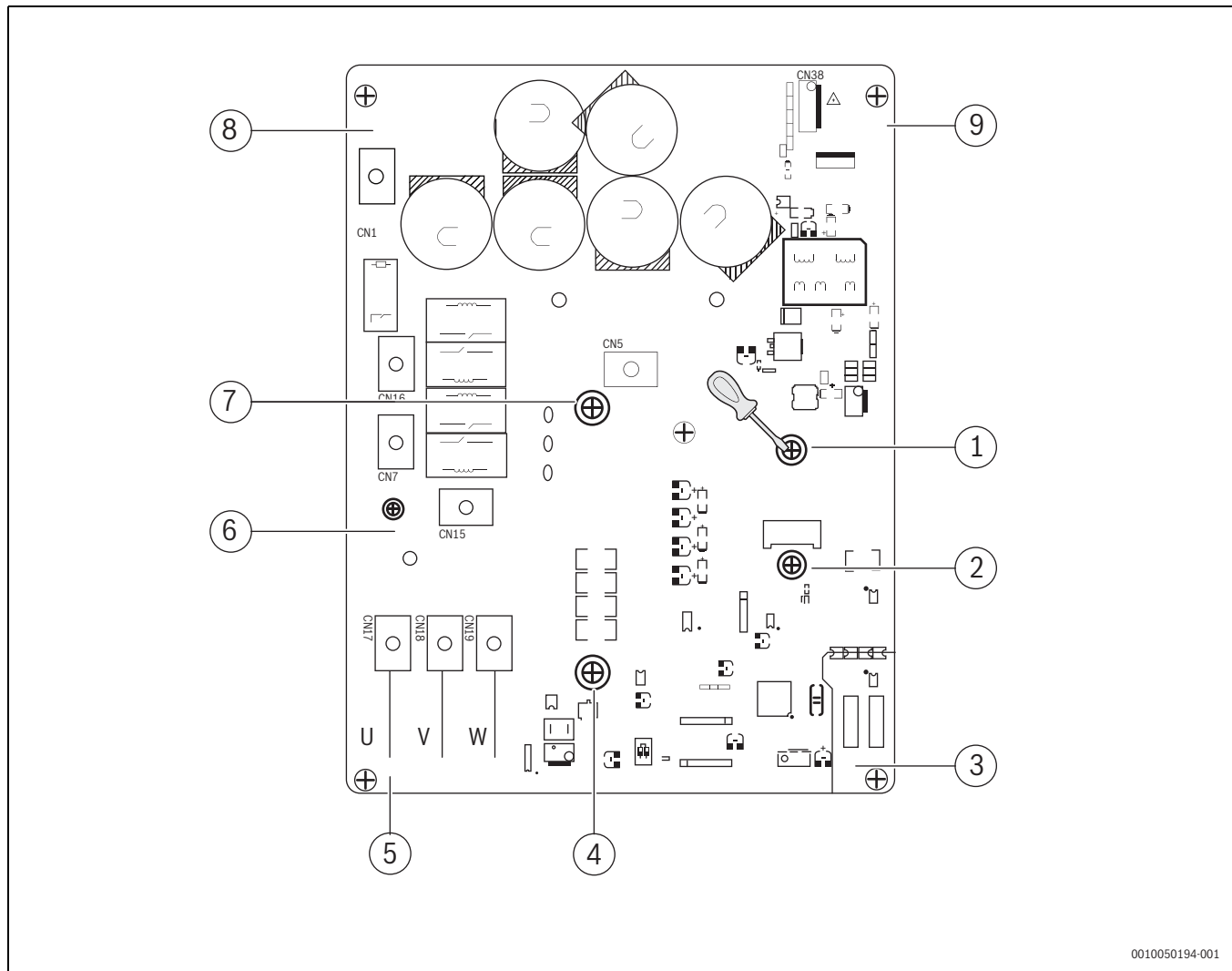

0010050194-001

Fig. 42 Compressor and fan drive board installation guide

DANGER

Risk of electric shock

- ▶ Before maintenance or repair to the outdoor unit, cut off the power supply to the unit for 5 minutes.
- ▶ Use a multimeter to ensure that the voltage is zero.

i

The unit has a low-power standby function. Only the power indicator of the main board is on after entering this mode.

Perform the following steps to install the module board:

1. Evenly apply thermal silicone grease on the IPM (the cooling panel on the back of the compressor and fan drive board).
2. Insert screws 1, 2, 4, and 7 respectively, and tighten them successively.
3. Insert screws 3, 5, 6, 8, and 9.
4. The order of steps 2 and 3 cannot be reversed. Do not attach the module directly without insertion, otherwise the module will be damaged by force when other screws are tightened.
5. Do not directly insert screws 8 and 9. Hang the module board and then tighten remaining screws.

Copper bar installation precautions:

- Each copper bar must be installed in its designated position and cannot be mixed.

- For copper bars with 2 or 3 screws, ensure that all screws are pre-fixed before being tightened in sequence. This prevents tension issues in other fixed positions caused by directly tightening one screw.
- After all screws are fixed, carefully check to ensure that each screw is tightened. Pay special attention to copper bars that require multiple screws for fixation. If one end is tightened while the other ends are not or if screws are missing, the wire connecting terminals may overheat, leading to potential burning or, in extreme cases, a fire.

6.3.7 Fan drive board ports

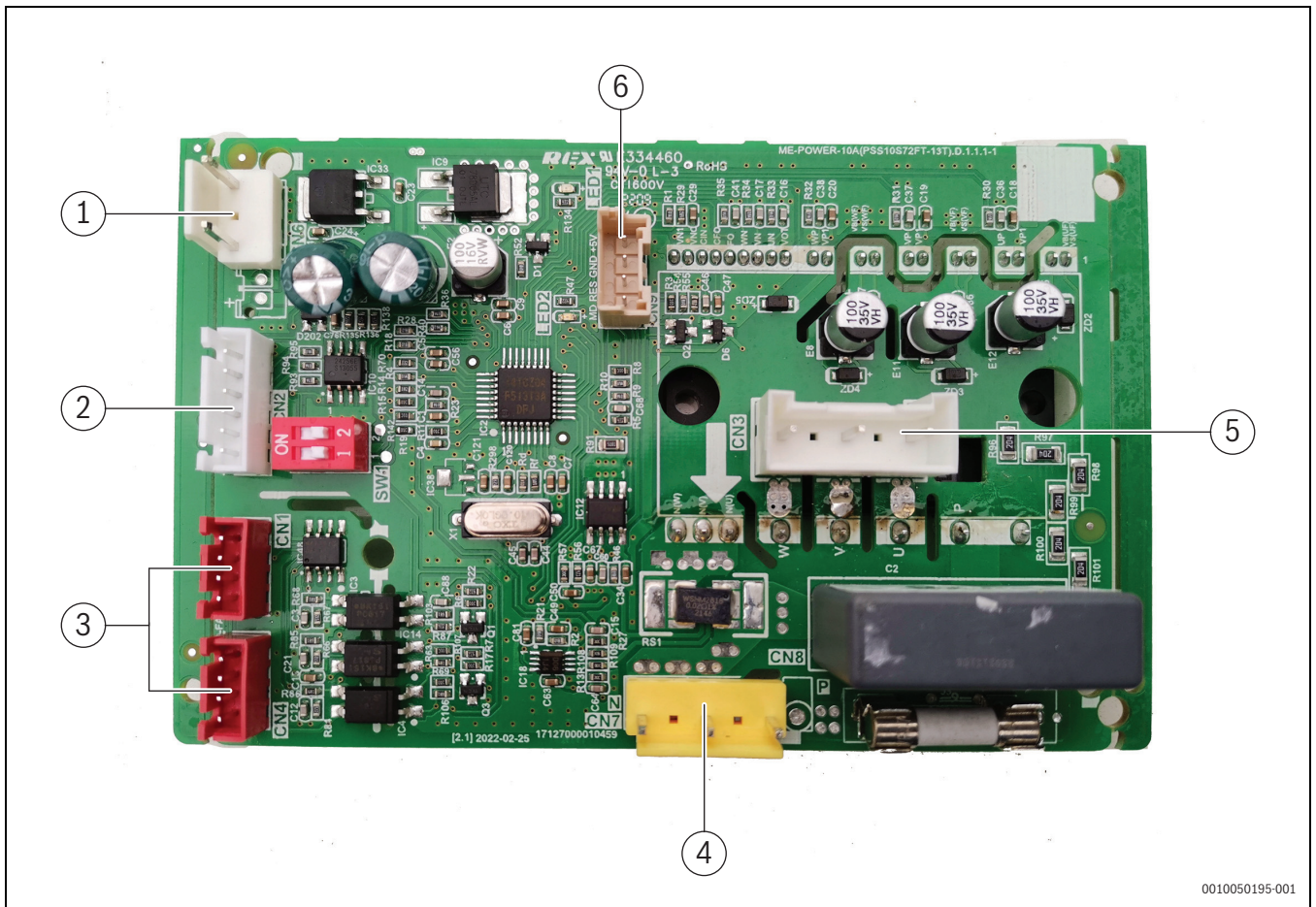

0010050195-001

Fig. 43 Fan drive board

Label in Fig. 43	Port code	Content	Port voltage
1	CN6	Fan module controls power supply (Reserved)	19V
2	CN2	EEPROM program burning port	5V
3	CN4/CN1	Communication port between main control board and fan drive board	5V
4	CN7	Power supply terminal for DC fan drive board (P,N) from main control board	Rated voltage 540V DC P(+), N(-)
5	CN3	Output power supply for fan motor	46...460V AC
6	CN9	Main program burning port	-

Table 40 Compressor and fan drive board port

6.4 Electrical wiring

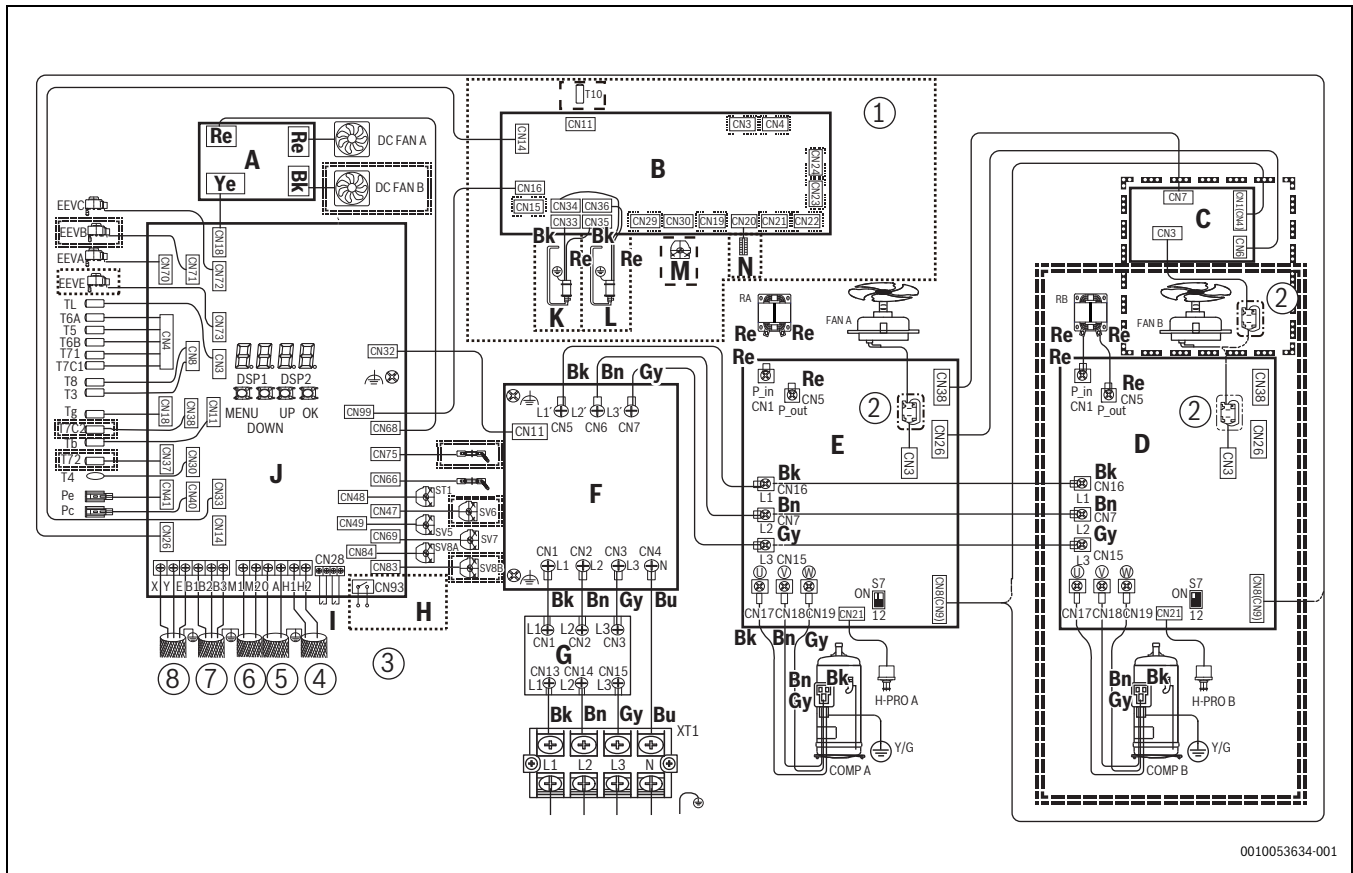

0010053634-001

Fig. 44

- [A] Power supply of the recirculation fan
- [B] Board (optional)
- [C] Fan drive board
- [D] Compressor and fan drive board B
- [E] Compressor and fan drive board A
- [F] Filter board of the indoor unit
- [G] Fuse board
- [H] Dry contact 3 output (passive) (optional)
- [I] Dry contact 1 and 2 input
- [J] Main control board
- [K] Chassis heat 2
- [L] Chassis heat 1
- [M] Spray device
- [N] Control box heat
- [1] Refer to the optional board manual for more details
- [2] Ferrite core (N=2)
- [3] H1/H2 is for combinable series only
- [4] Communication of the outdoor unit
- [5] Digital energy meter
- [6] M1/M2
- [7] Reserved
- [8] Contoller
- Bk Black
- Re Red
- Ye Yellow
- Gy Grey
- Bn Brown
- Bu Blue
- COMP A/B Compressor
- EEV A/B/C/E Electronic expansion valve
- FAN A/B DC fan
- DC FAN A/B Recirculation fan
- HEAT A/B Crankcase heater
- RA/RB Reactor
- ST1 Four-way valve
- SV5-SV8B Solenoid valve
- H-PRO A/B High pressure ON/OFF switch
- Pc High pressure sensor
- Pe Low pressure sensor
- T3 Temperature sensor of the main exchanger pipe
- T4 Outdoor ambient temperature sensor
- T5 Temperature sensor of the liquid stop valve inlet
- T6A Temperature sensor of the microchannel heat exchanger inlet
- T7C1/T7C2 Discharge temperature sensor
- T71/T72 Suction temperature sensor
- T8 Condenser inlet temperature sensor
- TL Condenser outlet temperature sensor
- Tg Gas pipe temperature sensor
- Tb Temperature sensor of the electric control box chamber
- XT1 Terminal block

- - - -	requires field installation of separately purchased parts (optional)
.....	after customization, installation is completed at the factory (customized)
=====	the port is welded on the main board, but the unit does not use the port (reserved)
- - - - -	for models with one compressor and two fans
-	for models with two compressor and two fans

Table 41 Dotted lines meaning

7 Diagnosis and troubleshooting

7.1 Error codes

The troubleshooting for each error code can be found in the service manual.

7.1.1 Outdoor unit error codes

Error code ¹⁾	Description	Remarks	Manual restart required?
A01	Emergency stop	Fault of the outdoor unit	No
xA61	No.x slave unit error	Fault of the slave unit	No
Aax	No.x Inverter driver board does not match the main control board	Fault of the outdoor unit	No
Xb53	No.x Heat dissipation fan error	System failure	Yes
C13	Outdoor unit address is repeated	Communication failure	No
C21	Communication error between indoor and outdoor unit	Communication failure	No
C26	Number of indoor units detected by outdoor unit has decreased	Communication failure	No
C28	Number of indoor units detected by outdoor unit has increased	Communication failure	No
xC31	Communication error between No.x of slave and master outdoor units	Communication failure	No
C32	Number of slave units detected by the master unit has decreased	Communication failure	No
C33	Number of slave units detected by the master unit has increased	Communication failure	No
xC41	Communication error between main control board and no.x inverter driver board	Communication failure	No
E41	Outdoor ambient temperature sensor (T4) error (open/short)	Sensor error	No
F31	Micro-channel heat exchanger outlet temperature sensor (T6B) error (open/short)	Sensor error	No
F41	Main heat exchanger pipe temperature sensor (T3) error (open/short)	Sensor error	No
F51	Micro-channel heat exchanger inlet temperature sensor (T6A) error (open/short)	Sensor error	No
F62	Inverter driver board temperature (Tf) protection	Temperature protection	No
F63	Non-inductive resistance temperature (Tr) protection	Temperature protection	No
F6A	F62 protection occurs 3 times in 100 minutes	Temperature protection	Yes
xF71	Discharge temperature sensor (T7C1/T7C2) error (open/short)	Sensor error	Yes
F72	Discharge temperature (T7C1/T7C2) protection	Temperature protection	No
F75	Compressor discharge insufficient superheat protection	Temperature protection	No
F7A	F72 protection occurs 3 times in 100 minutes	Temperature protection	Yes
F81	Gas stop-valve temperature sensor (Tg) error (open/short)	Sensor error	No
F91	Liquid pipe temperature sensor (T5) error (open/short)	Sensor error	No
FA1	Outdoor heat exchanger gas temperature sensor (T8) error (open/short)	Sensor error	No
FC1	Outdoor heat exchanger liquid temperature sensor (TL) error (open/short)	Sensor error	No
xFd1	Compressor suction temperature sensor (T71/T72) error (open/short)	Sensor error	No
Fp1	Electric control box chamber temperature sensor (Tb) error (open/short)	Sensor error	No
xL--	Compressor error; for "--" refer to table 44	Troubleshoot errors according to the service manual	Yes
xL01	xL1* or xL2* error occurs 3 times in 60 minutes; for "*" refer to table 44	Power on again	Yes

Error code ¹⁾	Description	Remarks	Manual restart required?
xJ--	No. (x) fan motor error; for "--" refer to table 45	Troubleshoot errors according to the service manual	Yes
xJ01	xJ1* or xJ2* error occurs 10 times in 60 minutes; for "*" refer to table 45	Power on again	Yes
P11	High pressure sensor error	Sensor error	No
P12	Discharge pipe high pressure protection	Pressure protection	No
P13	Discharge pipe high pressure switch protection	Pressure protection	No
P14	P12 error occurs 3 times in 60 minutes	Pressure protection	Yes
P21	Low pressure sensor error	Sensor error	Yes
P22	Suction pipe low pressure protection	Pressure protection	No
P24	Suction pipe low pressure abnormal rise	Pressure protection	No
P25	P22 error occurs 3 times in 100 minutes	Pressure protection	Yes
xP32	No.x compressor high DC bus current protection	Current protection	No
xP33	xP32 protection occurs 3 times in 100 minutes	Current protection	Yes
P51	High AC voltage protection	Voltage protection	No
P52	Low AC voltage protection	Voltage protection	No
P53	Phase B and N of the power cable are connected to the opposite protection	Power protection	Yes
P54	DC bus low voltage protection	Voltage protection	No
P55	DC bus ripple over protection	Power protection	Yes
xP56	No.x inverter module DC bus low voltage error	Power protection	Yes
xP57	No.x inverter module DC bus high voltage error	Power protection	Yes
xP58	No.x inverter module DC bus excessively high voltage error	Power protection	Yes
P71	EEPROM error	E party error	Yes
Pb1	Super Link overcurrent error	Overcurrent protection	Yes
Pd1	Anti-condensation protection	Condensation	No
Pd2	Pd1 protection occurs 2 times in 60 minutes	Condensation	Yes
1b01	Electronic expansion valve (EEVA) error	Missing connection	Yes
2b01	Electronic expansion valve (EEVB) error	Missing connection	Yes
3b01	Electronic expansion valve (EEVC) error	Missing connection	Yes
4b01	Electronic expansion valve (EEVE) error	Missing connection	Yes
bA1	Super Link cannot control the electronic expansion valve of the indoor unit	System error	Yes

1) The "x" in each error code is a placeholder for the fan A=1 or B=2.

Table 42 Outdoor unit error codes

7.1.2 Installation and debugging error codes

Error code	Description	Remarks	Manual restart required?
U11	Unit type is not set	System configuration	Yes
U12	Capacity setting error	System configuration	Yes
U21	Indoor unit with old platform in the system.	System configuration	Yes
U31	The test run was not successful.	Pilot run	Yes
U32	Outdoor temperature out of operating range	Pilot run	Yes
U33	Indoor temperature out of operating range	Pilot run	Yes
U34	Outdoor and indoor temperature out of operating range	Pilot run	Yes
U35	Liquid side stop valve is not opened	Pilot run	Yes
U37	Gas side stop valve is not opened	Pilot run	Yes
U38	No address	Outdoor unit set	Yes
U3A	The refrigerant pipe connection is not consistent with the communication cable	Pilot run	No
U3b	The installation environment is abnormal	Pilot run	Yes
U3C	VIP indoor unit is not set (valid in Changeover priority mode=	Pilot run	No
U4x	Overconnection ration contains U41-U46	System configuration	Yes
U51	Detected more than one outdoor unit in the individual VRF system	System configuration	Yes
U53	Detected different series outdoor units in the same VRF system	System configuration	Yes

Table 43 Installation and debugging error codes

7.1.3 Compressor driver error codes

Error code	Description	Remarks	Manual restart required?
xL1E	Hardware overcurrent	Current overload error	No
xL11	Software overcurrent	Current overload error	No
xL12	Software overcurrent protection last 30s	Current overload error	No
xL2E	Module high temperature protection	Over-temperature error	No
xL3E	Low bus voltage error	Power supply error	No
xL31	High bus voltage error	Power supply error	No
xL32	Excessive over voltage error of bus	Power supply error	No
xL33	Bus voltage drop fault	Power supply error	No
xL43	Abnormal current sampling	Hardware error	No
xL5E	Start-up failed	Control error	No
xL51	Out-of-step error	Control error	No
xL52	Locked-rotor protection	Motor error	No
xL6E	Motor phase loss protection	Diagnosis error	No

Table 44 Compressor driver error codes

7.1.4 Fan motor error codes

Error code ¹⁾	Description	Remarks	Manual restart required?
xJ1E	Hardware overcurrent	Current overload error	No
xJ11	Software overcurrent	Current overload error	No
xJ12	Software overcurrent protection last 30s	Current overload error	No
xJ2E	Module high temperature protection	Over-temperature error	No
xJ3E	Low bus voltage error	Power supply error	No
xJ31	High bus voltage error	Power supply error	No
xJ32	Excessive over voltage error of bus	Power supply error	No
xJ43	Abnormal current sampling	Hardware error	No
xJ5E	Startup failed	Control error	No
xJ51	Out-of-step error	Control error	No
xJ52	Locked-rotor protection	Control error	No
xJ6E	Motor phase loss protection	Diagnosis error	No

1) The "x" in each error code is a placeholder for the fan/compressor A=1 or B=2.

Table 45 Fan motor error codes

7.1.5 Status codes

Status code	Description	Remarks	Manual restart required?
d0x	Oil return running, "x" represents oil return operation steps	Status hint	No
dfx	Defrost running, "x" represents defrosting operation steps	Status hint	No
d11	Outdoor ambient temperature exceeds the upper limit in Heating mode	Status hint	No
d12	Outdoor ambient temperature exceeds the lower limit in Heating mode	Status hint	No
d13	Outdoor ambient temperature exceeds the upper limit in Cooling mode	Status hint	No
d14	Outdoor ambient temperature exceeds the lower limit in Cooling mode	Status hint	No
d31	Refrigerant judgment, no result	Status hint	No
d32	Refrigerant quantity judgment, significantly excessive	Status hint	No
d33	Refrigerant quantity judgment, slightly excessive	Status hint	No
d34	Refrigerant quantity judgment, normal	Status hint	No
d35	Refrigerant quantity judgment, slightly insufficient	Status hint	No
d36	Refrigerant quantity judgment, significantly insufficient	Status hint	No
d41	System exist no power indoor unit, Super Link is controlling the valve of the indoor unit	Status hint	No

Table 46 Status prompt codes

7.2 Troubleshooting

7.2.1 Warning

- ▶ All electrical work must be carried out by competent and suitably qualified, certified and accredited professionals and in accordance with all applicable legislation (all national, local and other laws, standards, codes, rules, regulations and other legislation that apply in a given situation).

7.2.2 Error in main control

7.2.3 A01: Emergency shut-down of outdoor units

Digital display output

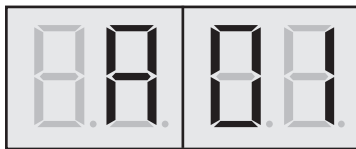

0010050039-001

Description

- Compressor protection shut-down
- All outdoor units stop running
- Error codes are displayed only on master unit.

Trigger/recover condition

Check menu n28 = 0:

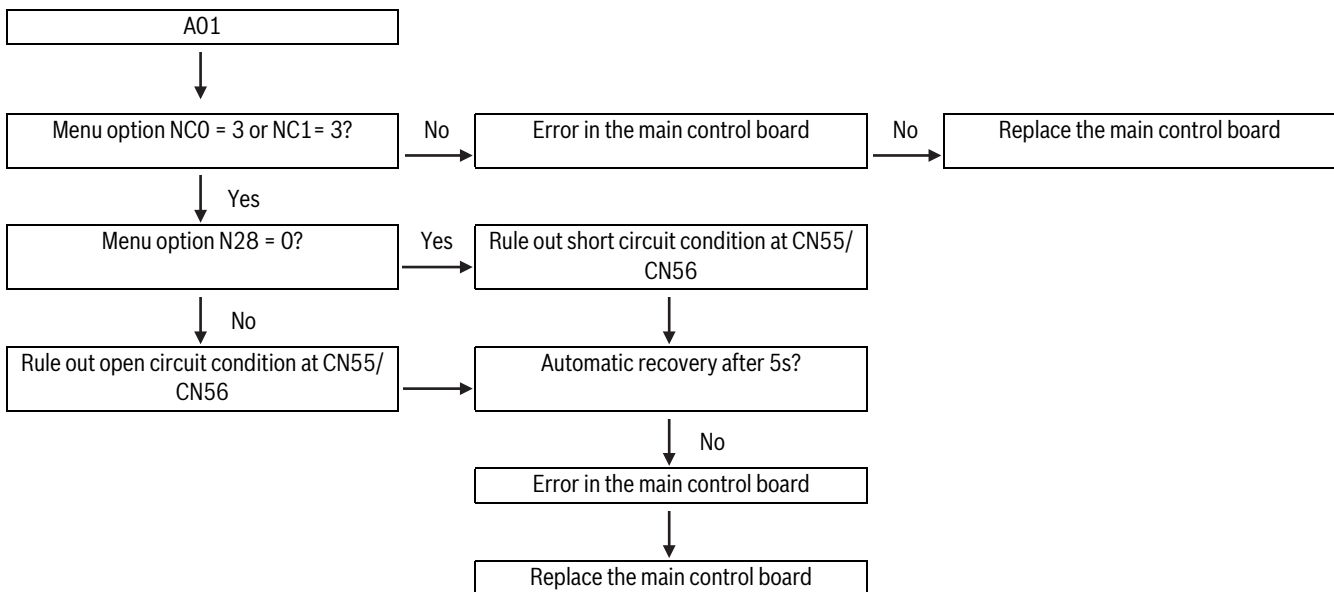

- ▶ Power-off the unit before connecting or disconnecting any connections or wiring. Otherwise electric shock may occur, leading to damage to components, physical injury or death.

- Trigger condition: Dry contact x (main control board CN55/CN56) is short-circuited.
- Recover condition: remove Dry contact x short-circuited.
- Reset method: resume automatically.

Check menu n28 = 1:

- Trigger condition: Dry contact (PCB CN55/CN56) is open circuited.
- Recover condition: remove Dry contact x short-circuited.
- Reset method: resume automatically.

Possible causes

- Damaged outdoor unit main control board.
- Centralized controller command
- Emergency shut-down triggered by external causes

Procedure

7.2.4 xA61: No.x of slave units error

Digital display output

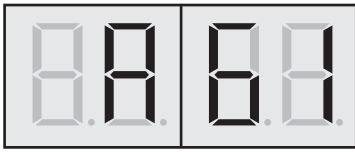

0010055147-001

Description

- xA61 shows the outdoor unit at address X is in error (X = 1, 2, 3)

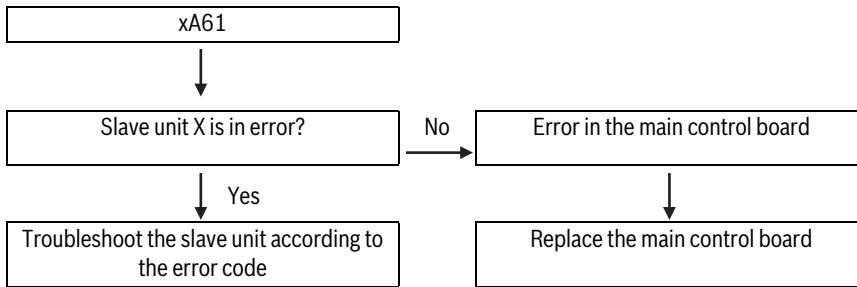

- All outdoor units stop running
- Error codes are displayed only on master unit.

Trigger/recover condition

- Trigger condition: slave unit is in error
- Recover condition: error of slave unit recovery
- Reset method: resume automatically.

Possible causes

- Driven machine is in error.

Procedure

7.2.5 AAx: Inverter driver board X does not match the main control board

Digital display output

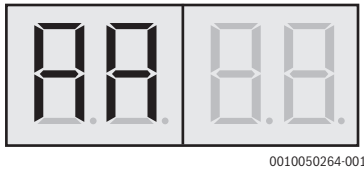

Description

- No.x Inverter driver board does not match the main control board.
- All outdoor units stop running.

- Error code is displayed on the unit with the error.

Trigger/recover condition

- Trigger condition: The internal driver parameters of the module board do not match outdoor units.
- Recover condition: The internal driver parameters of the module board match outdoor units.
- Reset method: Rectify the error and power-on again.

Possible causes

- Model error of inverter driver board.
- Outdoor unit model is incorrectly set.
- Main control board is damaged.

Procedure

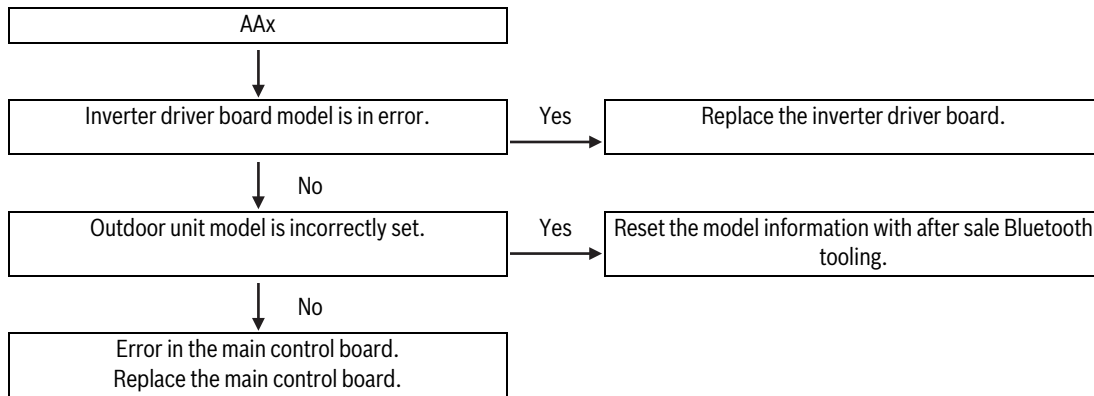

7.2.6 xb53: No.x Recirculation fan error

Digital display output

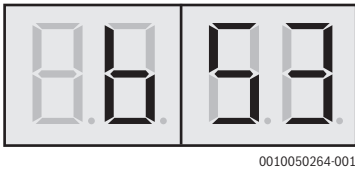

Description

- No.x Recirculation Fan[1] is in error.
- All units stop running.
- Error code is displayed on the unit with the error.

Procedure

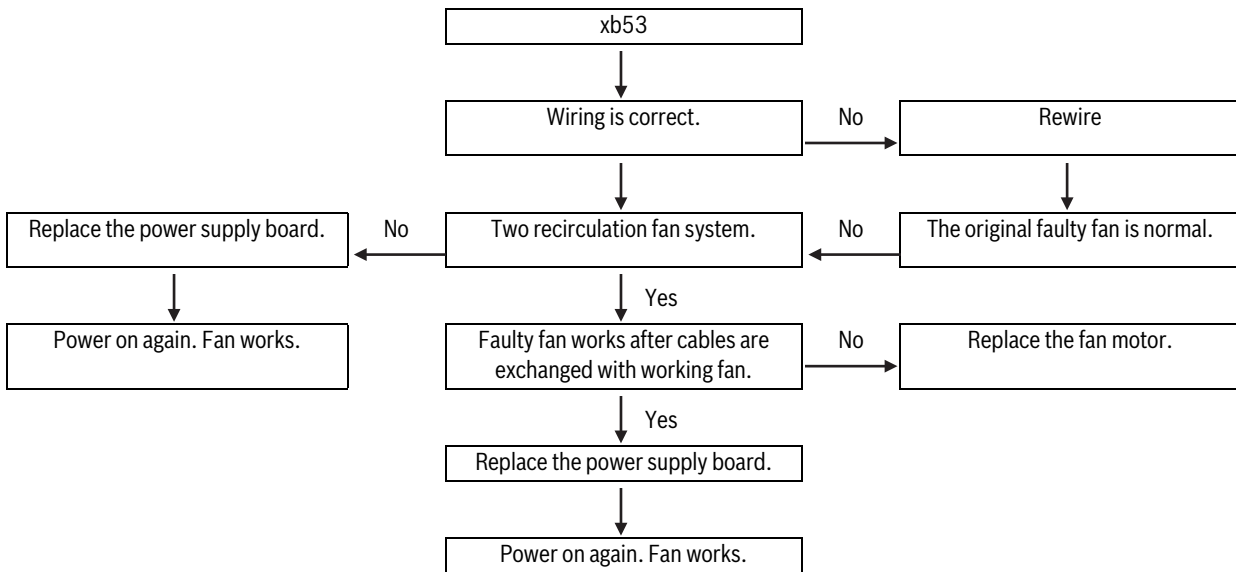

Trigger/recover condition

- Trigger condition: The difference between the actual fan speed and the set fan speed is 300rpm, lasting for 50s.
- Recover condition: The difference between the actual fan speed and the set fan speed is within 300rpm.
- Reset method: Rectify the error and power-on again.

Possible causes

- The cable connecting the recirculation fan with the power supply is disconnected.
- The recirculation fan is damaged.
- The recirculation fan power supply is damaged.
- Outdoor unit main control board is damaged.

7.2.7 bA1: SuperLink cannot open or close indoor unit's Electronic Expansion Valve

Digital display output

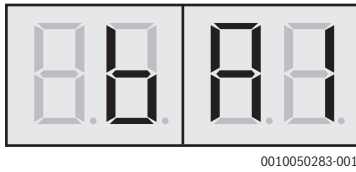

Description

- When some indoor units are powered off, SuperLink fails to close their EEV.
- All units stop running.
- Error code is only displayed on the outdoor unit.

Trigger/recover condition

- Trigger condition: When some indoor units in the system are powered off, SuperLink board voltage < 17V.
- Recover condition: SuperLink board voltage > 17V.
- Reset method: Resume manually.

Possible causes

- SuperLink communication line diameter < 1.5mm².
- The total length of SuperLink communication cables exceeds 200 meters without a repeater.
- The number of powered off indoor units > 10 and have no repeaters.
- Indoor main control board is damaged.
- Outdoor main control board is damaged.

Procedure

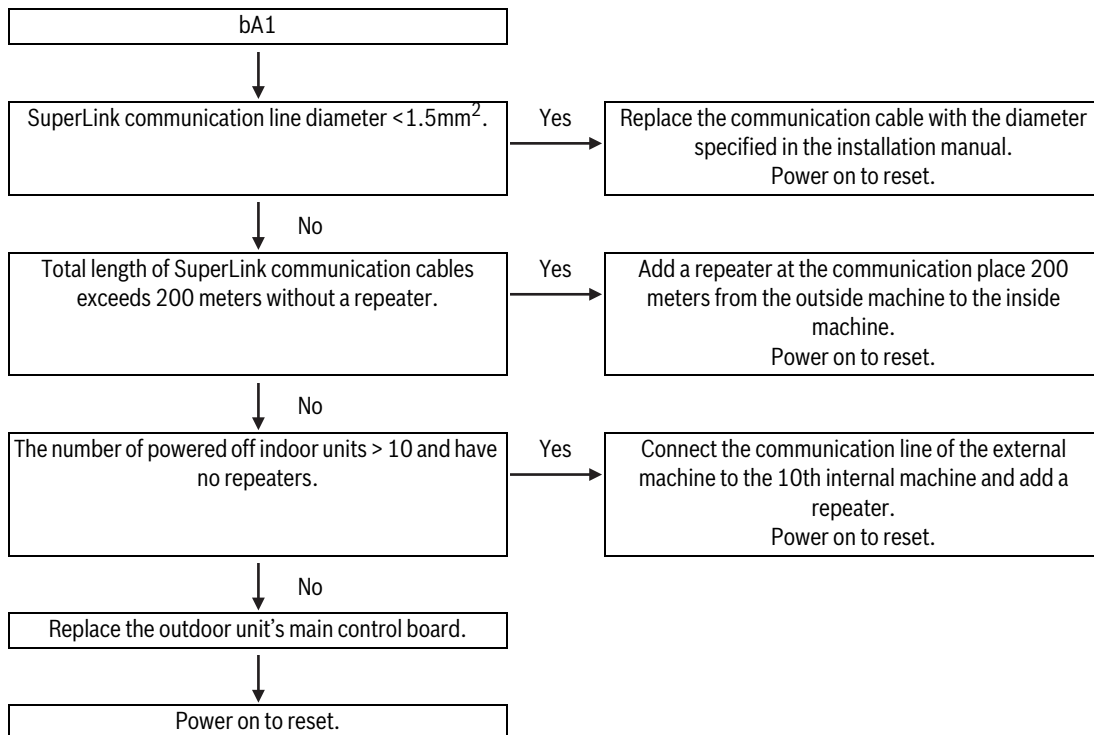

7.2.8 U38: Outdoor unit has no address

Digital display output

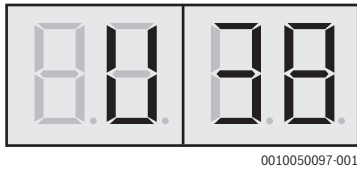

Description

- Outdoor unit has no address.

- The outdoor unit with error can not run.
- The outdoor unit cannot communicate with indoor units.

Trigger/recover condition

- Trigger condition: The outdoor unit's address is not set.
- Recover condition: Enter the menu N40 to reset the outdoor unit address. The master address is 0 and the slave address is 1-3.
- Reset method: Resume manually.

Possible causes

- The outdoor unit's address is not set.
- Outdoor main control board is damaged.

Procedure

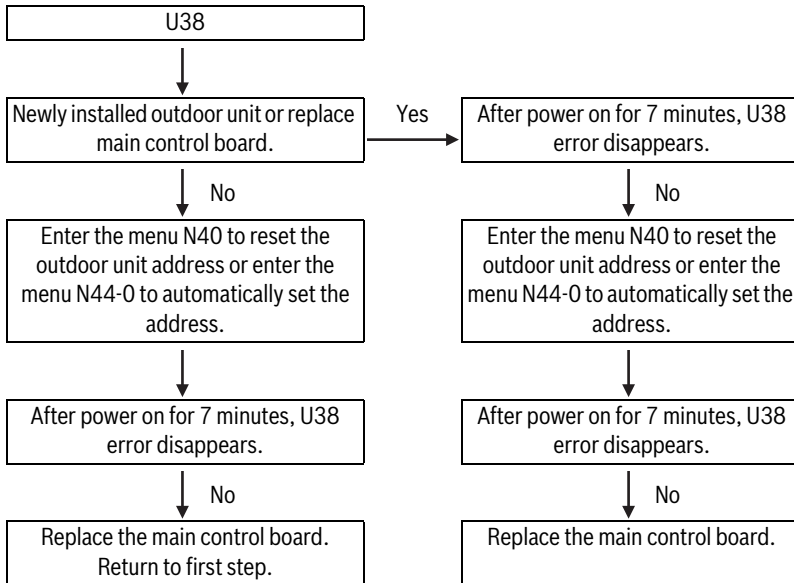

7.2.9 C13: The address of the outdoor unit is repeated

Digital display output

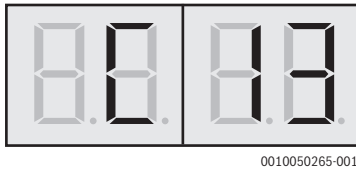

Description

- The address of the outdoor unit is repeated.

Procedure

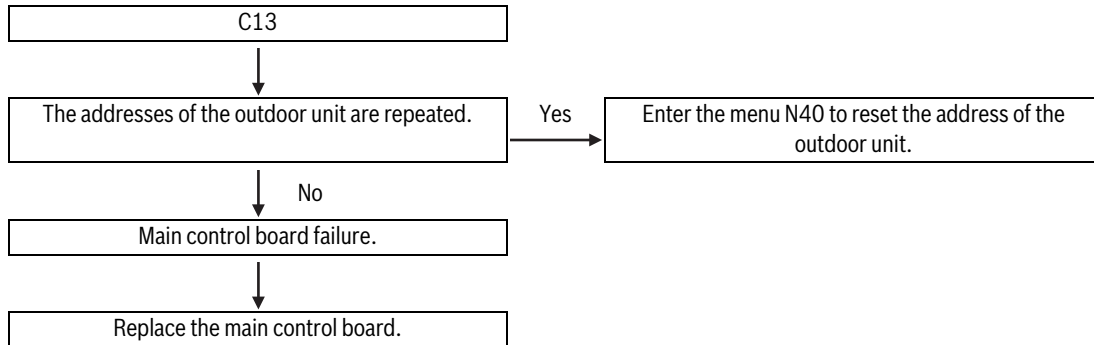

Trigger/recover condition

- Trigger condition: Two or more outdoor units in the combined system have the same address.
- Recover condition: The address of master and slave unit are set to 0-3 successively.

Possible causes

- Two or more outdoor units in the combined system have the same address.
- Outdoor main control board is damaged.



After setting the address of the outdoor unit, wait 30 seconds before powering off the device. Wait another 30 seconds, and power on the device. The master address must be set to 0.

7.2.10 C21: Communication error between indoor and outdoor unit

Digital display output

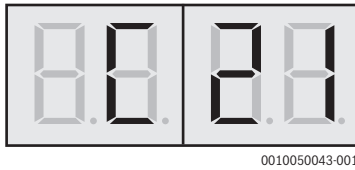

Description

- Communication error between indoor unit and outdoor unit.
- All units stop running.
- Error code is only displayed on the outdoor unit.

Trigger/recover condition

- Trigger condition: 20 minutes after the outdoor unit is powered on, the communication signal from the indoor unit cannot be received by the outdoor unit for two minutes.
- Recover condition: The outdoor unit receives the communication signal from the indoor unit.
- Reset method: Resume automatically.

Possible causes

- M1M2 communication is adopted¹⁾.
 - The communication cable is not tightened or the surface contact of the wiring block is poor.
 - Communication line is disturbed by strong electromagnetic waves.
 - The communication cable is disconnected or in bad contact due to various reasons.
 - The address of an indoor unit is incorrect.
 - Indoor main control board is damaged.
 - Outdoor main control board is damaged.

1) N45-2 indoor units uniform power supplied; N45-3-indoor units separate power supplied.

Procedure

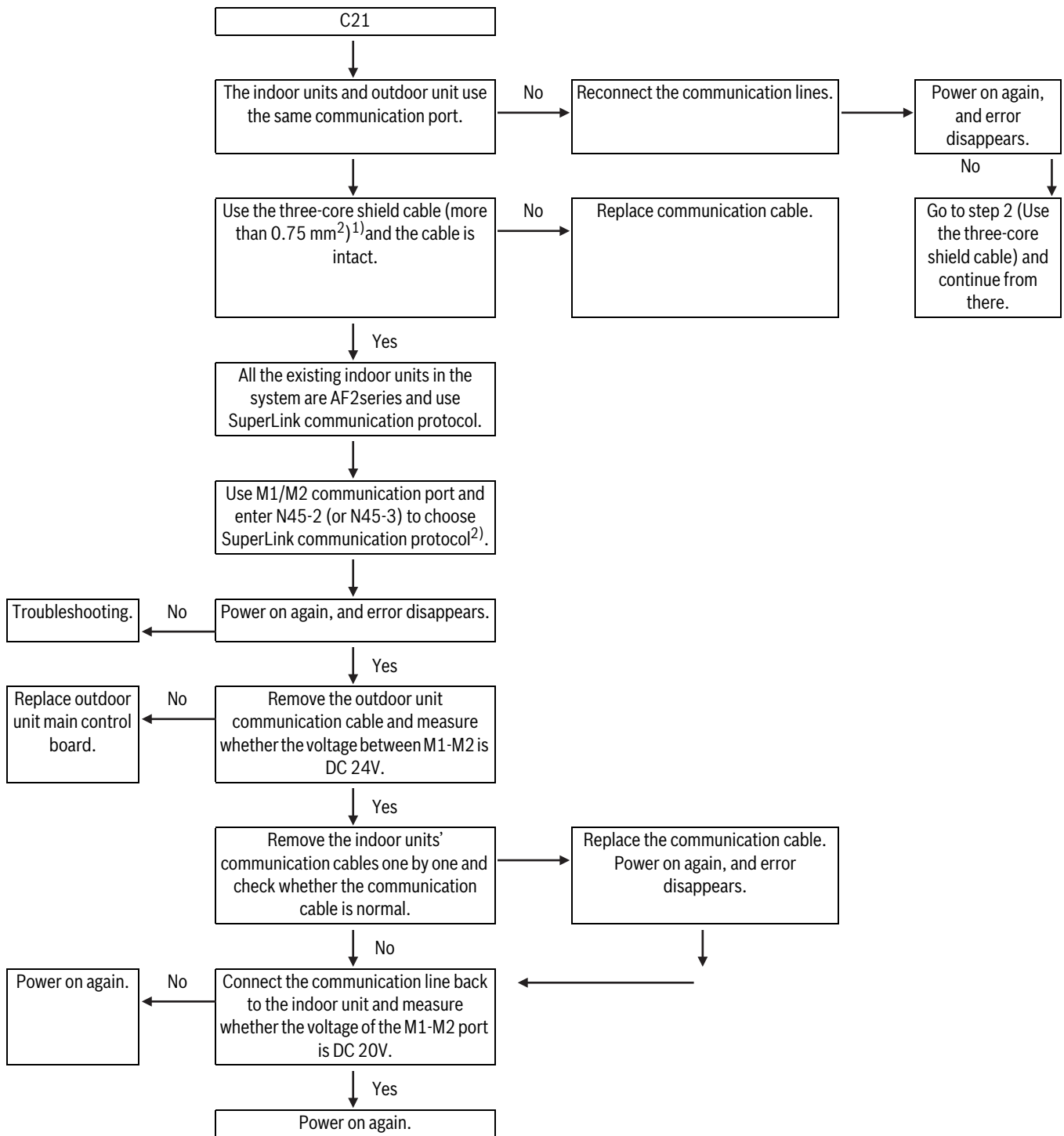

1) If SuperLink communication is used, the communication wire diameter should be 1.5mm².
 2) N45-2 indoor units uniform power supplied; N45-3-indoor units separate power supplied.

7.2.11 C26: Abnormal reduction in the number of indoor units

Digital display output

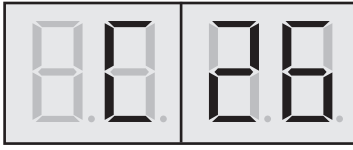

0010050044-001

Description

- The number of online indoor units is smaller than the configured number.
- All units stop running.
- Error code is only displayed on the outdoor unit.

Trigger/recover condition

- Trigger condition:
 - N0: The number of indoor units set by outdoor unit; N1: The number of online machines.
 - During operation, $N1 < N0$ and lasts for 2 minutes.
 - After the first power on, $N1 < N0$ within 20 minutes, outdoor unit can not start and displays that error.
- Recover condition: $N1 = N0$ for 60 seconds.
- Reset method: Resume automatically.

Possible causes

- The three-core shield cable is not in use or the shield layer is not grounded.
- The communication cable is not tightened or the surface contact of the wiring block is poor.
- Communication cable is disturbed by strong electromagnetic wave.
- The communication cable is disconnected or in bad contact due to various reasons.
- The address of an indoor unit is incorrect.
- Indoor main control board is damaged.
- Outdoor main control board is damaged.
- The number of indoor units set by the outdoor unit is inconsistent with the actual number of indoor units.

Procedure

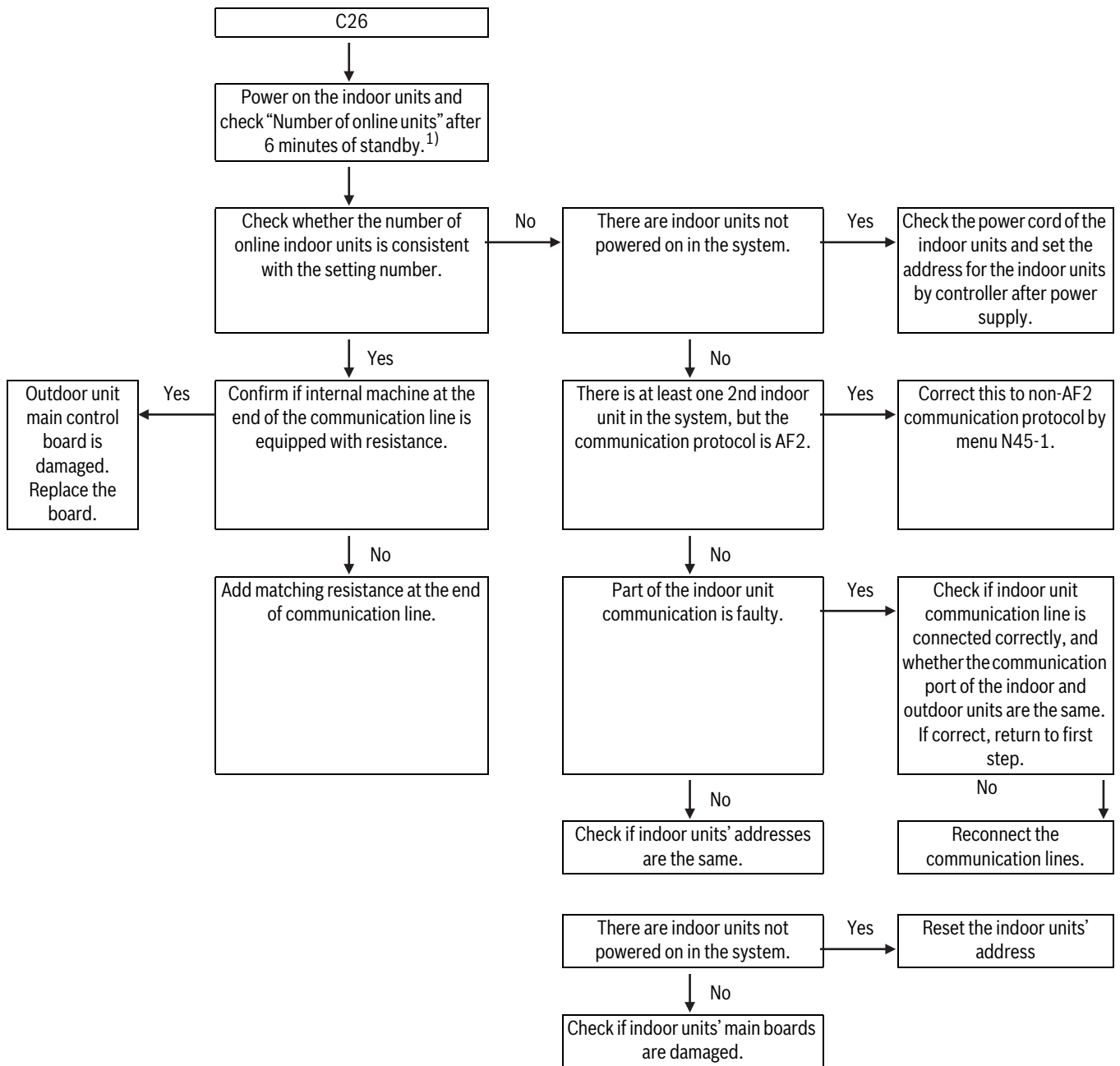

1) Check the number of indoor units set by outdoor unit.

7.2.12 C28: Abnormal increase in the number of indoor units

Digital display output

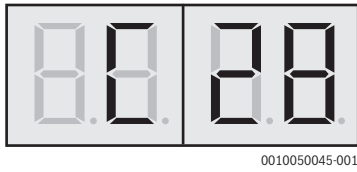

Description

- Abnormal increase in the number of indoor units.
- All units stop running.
- Error code is only displayed on the outdoor unit.

Trigger/recover condition

- Trigger condition:
 - N0: The number of indoor units set by outdoor unit; N1: The number of online machines.
 - During operation, $N1 > N0$ and lasts for 2 minutes.
 - After the first power on, $N1 > N0$ within 20 minutes, outdoor unit cannot start and displays that error.

- Recover condition: $N1 = N0$ for 60 seconds.
- Reset method: Resume automatically.

Possible causes

- The three-core shield cable is not in use or the shield layer is not grounded.
- The communication cable is not tightened or the surface contact of the wiring block is poor.
- Communication cable is disturbed by strong electromagnetic wave.
- The communication cable is disconnected or in bad contact due to various reasons.
- The address of an indoor unit is incorrect.
- Indoor main control board is damaged.
- Outdoor main control board is damaged.
- The number of indoor units set by the outdoor unit is inconsistent with the actual number of indoor units.

Procedure

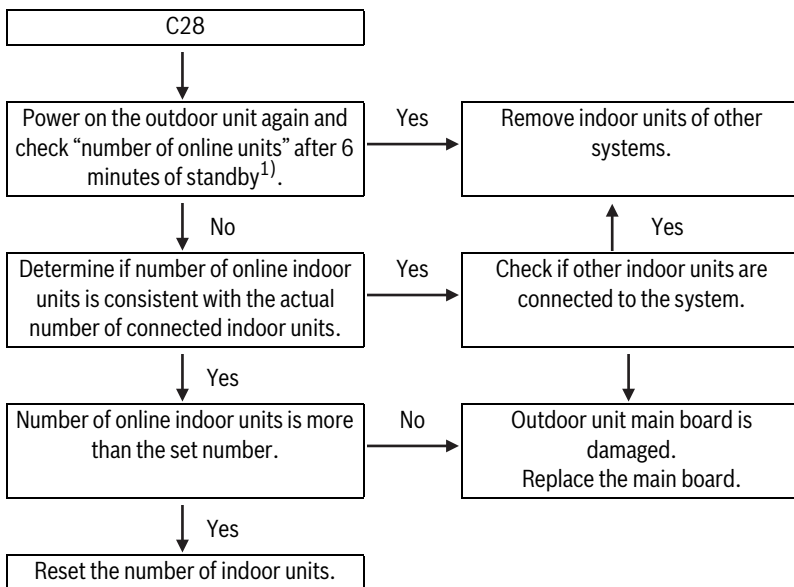

1) Check the number of indoor units set by outdoor unit.

7.2.13 xC31: Communication error between No.x of slave and master outdoor units

Digital display output

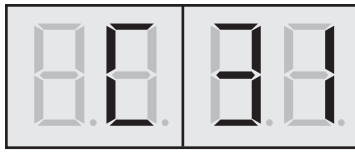

0010055153-001

Description

- The No.x outdoor slave unit cannot communicate with the outdoor master unit.
- All units stop running.
- Error code is only displayed on the slave unit with the error.

Trigger/recover condition

- Trigger condition: The communication between the slave unit and the master unit of the combined system is interrupted for more than 2 minutes.
- Recover condition: The communication between the slave unit and the master unit of the combined system is restored.
- Reset method: Power off the device for 30 seconds and then power it on again.

Possible causes

- Communication cables are not tightened on the wiring block.
- The surface of the wiring block is corroded.
- The outdoor unit address is incorrectly set.
- Outdoor main control board is damaged.

Procedure

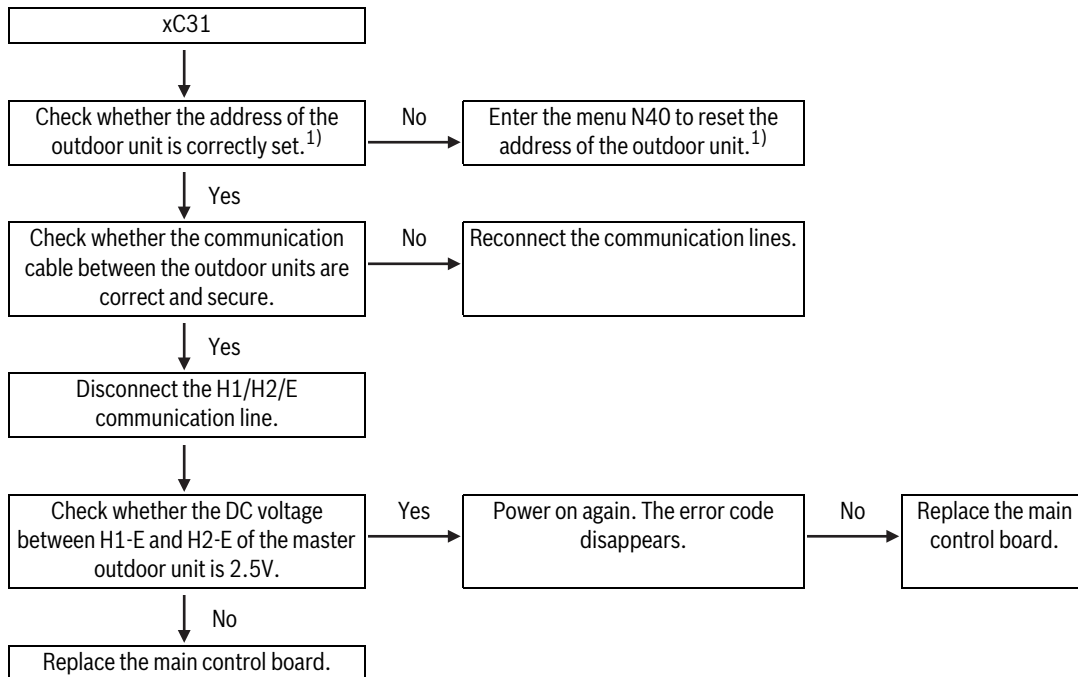

¹⁾The master is 0, and the slave is 1-3.

7.2.14 C32: Number of slave units detected by the master unit has decreased

Digital display output

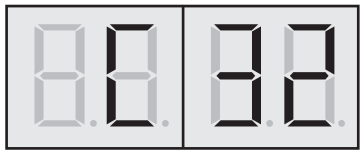

0010055152-001

Description

- The number of online slave outdoor units detected by the master outdoor unit decreases.
- All units stop running.
- Error code is only displayed on the master unit.

Trigger/recover condition

- Trigger condition: The number of online outdoor slave units detected by the outdoor master unit decreases.
- Recover condition: The number of outdoor units is restored.
- Reset method: Resume automatically.

Possible causes

- Some outdoor slave units are powered off.
- The addresses of the outdoor units are repeated.
- The outdoor unit address is incorrect.
- The H1/H2 cable sequence is incorrect
- The outdoor units do not support the combined connection.
- Outdoor main control board is damaged.

Procedure

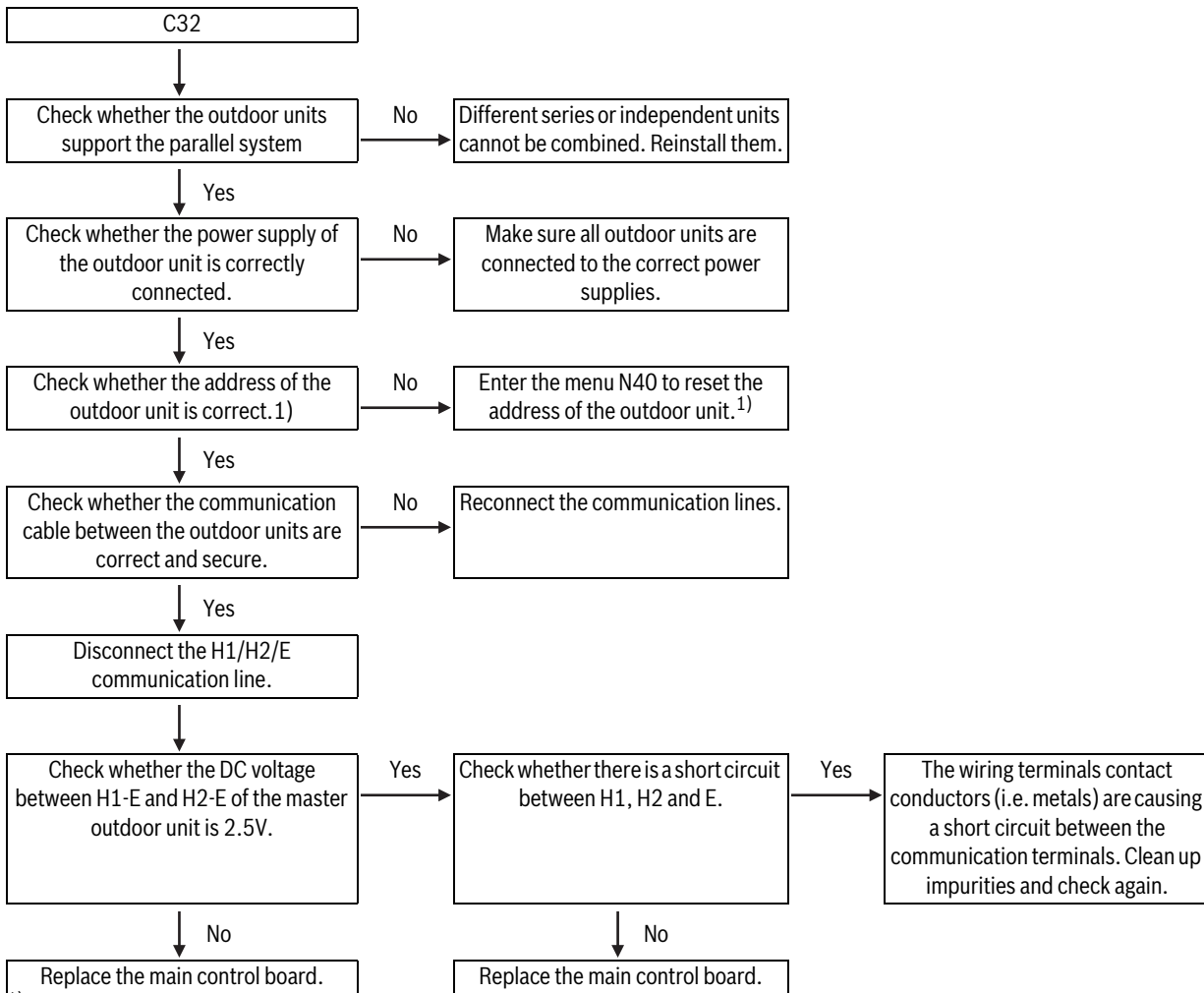

¹⁾The master is 0, and the slave is 1-3.

7.2.15 C33: Number of slave units detected by the master unit has increased

Digital display output

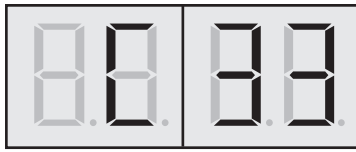

0010055151-001

Description

- The number of online outdoor slave units detected by the outdoor master unit increases.
- All units stop running.

Procedure

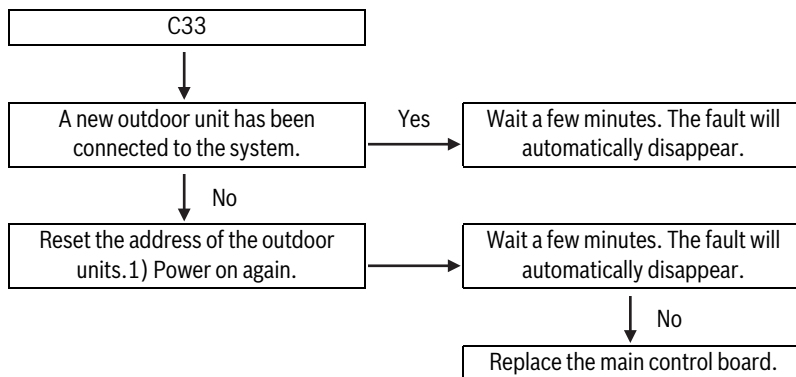

¹⁾The master is 0, and the slave is 1-3.

- Error code is only displayed on the master unit.

Trigger/recover condition

- Trigger condition: One or more slave outdoor unit has been recently connected during system operation.
- Recover condition: Check the system connection status and power on the system again.
- Reset method: Resume manually.

Possible causes

- The number of outdoor unit increases (one or more slave outdoor units have been recently added to the combined system).
- Set the outdoor unit address correctly if it is repeated or incorrect.

7.2.16 xC41: Communication error between main control board and No.x inverter driver board

Digital display output

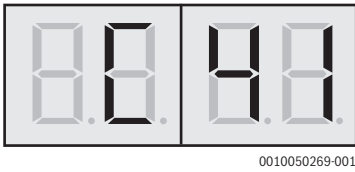

Description

- The communication between the main control board and no.x inverter driver board is error.
- All units stop running.

Procedure

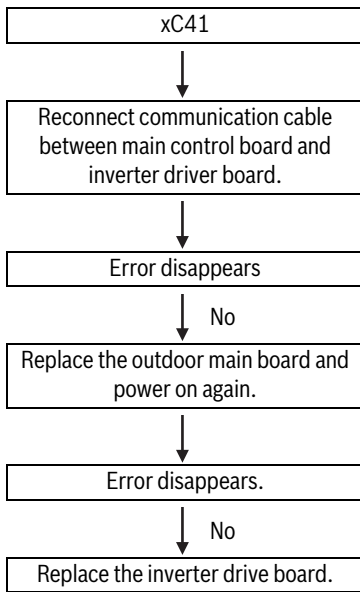

- Error codes are displayed only on outdoor unit.

Trigger/recover condition

- Trigger condition: Communication between main control board and no.x inverter driver board is interrupted for more than 2 minutes.
- Recover condition: Communication between the main control board and No.x inverter driver board is restored.
- Reset method: Resume automatically.

Possible causes

- Communication between main control board and no.x inverter driver board is interrupted.
- No.x inverter driver board is damaged.
- Main control board is damaged.

7.2.17 E41,F31,F41,F51,xF71,F81,F91,FA1,FC1,xFd1,Fp1: Temperature sensor error

Digital display output











Error code	Error description	Remarks	Digital display output
E41	Outdoor ambient temperature sensor (T4) error (open/short)	sensor error	 <small>0010050048-001</small>
F31	Microchannel heat exchanger outlet temperature sensor (T6B) error (open/short)	sensor error	 <small>0010050049-001</small>
F41	Main heat exchanger pipe temperature sensor (T3) error (open/short)	sensor error	 <small>0010050050-001</small>
F51	Microchannel heat exchanger inlet temperature sensor (T6A) error (open/short)	sensor error	 <small>0010050270-001</small>
xF71	Discharge temperature sensor (T7C1/T7C2) error (open/short)	sensor error	 <small>0010050062-001</small>
F81	Gas pipe temperature sensor (Tg) error (open/short)	sensor error	 <small>0010050271-001</small>
F91	Liquid pipe temperature sensor (T5) error (open/short)	sensor error	 <small>0010050052-001</small>
FA1	Outdoor Heat exchanger gas temperature sensor (T8) error (open/short)	sensor error	 <small>0010050053-001</small>
FC1	Outdoor heat exchanger liquid temperature sensor (TL) error (open/short)	sensor error	 <small>0010050054-001</small>
xFd1	Compressor suction temperature sensor (T71/T72) error (open/short)	sensor error	 <small>0010050055-001</small>
Fp1	Electric control box chamber temperature sensor (Tb) error (open/short)	sensor error	 <small>0010050272-001</small>

Table 47

Description

- All units stop running.
- Error code is displayed on the unit with the error.

Trigger/recover condition

- Trigger condition: The main control board cannot obtain the normal AD value of the temperature sensor.
- Recover condition: The main control board obtain the normal AD value of the temperature sensor.

Procedure

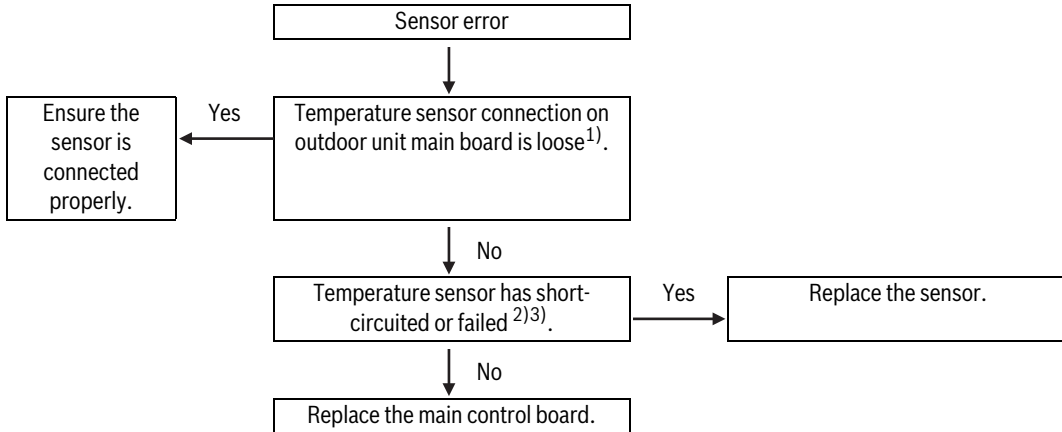

- 1) The port on the main control board corresponding to the Temperature sensor refer to Main Control Board port definition.
- 2) Measure sensor resistance. Remove the sensor and use a multimeter to measure the sensor access resistance. If the resistance value is smaller than 0.5k Ω (T7C1/T7C2 is 0.97 k Ω), the sensor is short-circuited. If the impedance is higher than 380 k Ω(T7C1/T7C2 is 743 k Ω), the sensor is opencircuited (Refer to Temperature sensor resistance characteristic).
- 3) Measure the voltage of the port on main control board. If the sensor resistance is normal, then use a multimeter to measure the port voltage. If the port voltage is not 3.3V when main control board is powered on, the main control board is damaged and must be replaced.

- Reset method: Resume automatically.

Possible causes

- The temperature sensor is not properly connected to the main control board.
- Sensor failure.
- The main control board is damaged.

7.2.18 F62, F6A: Inverter driver board NTC over temperature protection

Digital display output

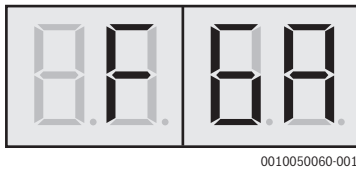
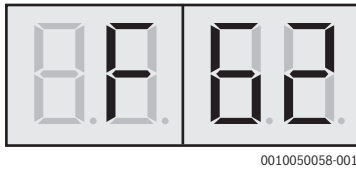

Description

- All units stop running.
- Error code is only displayed on the outdoor unit.

Trigger/recover condition

- Trigger condition:
 - The NTC temperature inside the compressor board or fan module is higher than 100 °C.
 - F6A: F62 protection occurs 3 times in 100 minutes.
- Recover condition: The NTC temperature is lower than 80 °C.
- Reset method:
 - F62: Resume automatically. F6A: Manually restart.

Possible causes

- Inverter driver board is in poor contact with the radiator.
- The thermal grease layer is missing.
- Inverter driver board is damaged.

Procedure

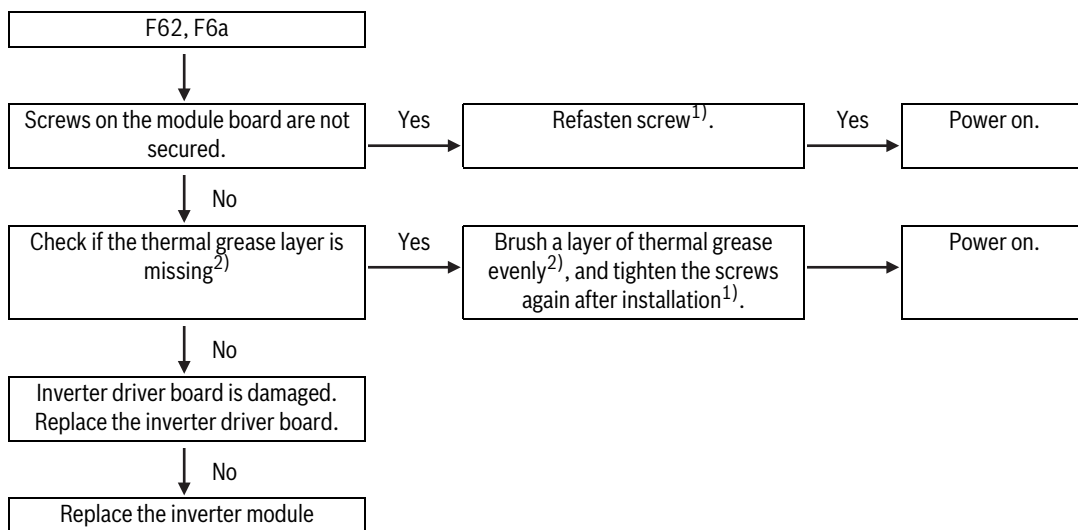

1) Reinstall the Inverter driver board, refer to Compressor and fan drive board installation guide.

2) The thermal grease layer is located between the Inverter driver board and the radiator, and the thickness is about 0.2 mm. If the thermal grease layer is in poor condition, it may lead to poor heat dissipation effect. Clean and fill it again.

7.2.19 F63: Non-inductive resistance T_r over temperature protection

Digital display output

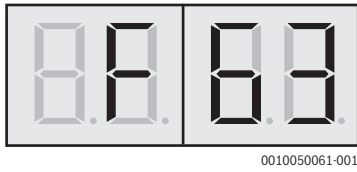

Description

- All units stop running.
- Error code is displayed on the outdoor unit with the error.

Trigger/recover condition

- Trigger condition: The non-inductive resistance temperature exceeds 95 °C.
- Recover condition: The non-inductive resistance temperature is lower than 70 °C.
- Reset method: Resume automatically.

Possible causes

- The recirculation fan in the electric control box works improperly (Top Flow Series).
- The air intake grille at the bottom of the machine or the internal air duct is blocked (Side Flow Series).
- Inverter driver board is damaged.

Procedure

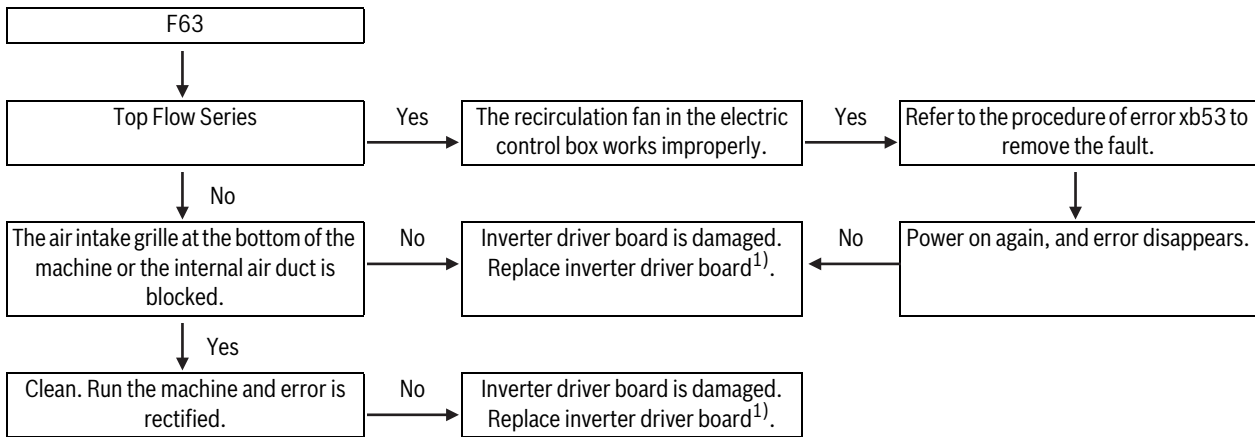

1) To reinstall the inverter driver board, refer to Compressor and fan drive board installation guide.

7.2.20 F72, F7A: Discharge temperature protection

Digital display output

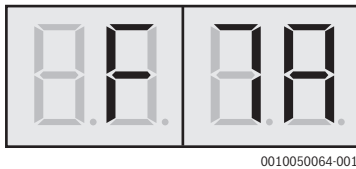
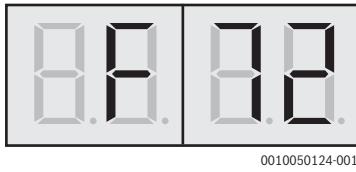

- All outdoor units stop running.
- Error code is displayed on the outdoor unit with the error.

Trigger/recover condition

- Trigger condition:
 - F72: Discharge temperature (T7C1/T7C2) $\geq 115^\circ\text{C}$.
 - F7A:F72 protection occurs 3 times in 100 minutes.
- Recover condition: Discharge temperature (T7C1/T7C2) $< 90^\circ\text{C}$.
- Reset method:
 - F72: Resume automatically.
 - F7A: Manually restart.

Possible causes

- The discharge temperature sensor temperature failure.
- Main control board is damaged.
- The discharge temperature sensor temperature is too high.

Description

- Discharge temperature is over the limit.

Procedure

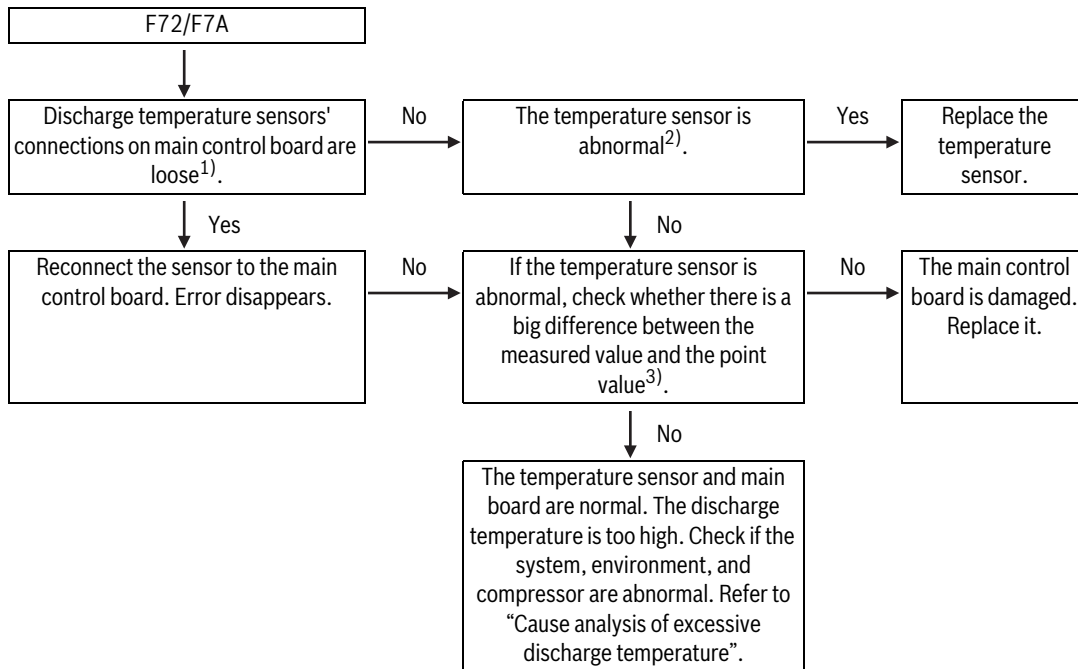

- 1) The main control board port of discharge temperature sensor 1 (T7C1) is CN4 and discharge temperature sensor 2(T7C2) is CN38.
- 2) Measure sensor resistance. If the resistance is too low, the sensor has short-circuited. If the resistance is not consistent with the sensor's resistance characteristics table, the sensor has failed. Refer to Temperature sensor resistance characteristic.
- 3) Use the temperature measuring tool to measure the discharge temperature. Less refrigerant system results in higher discharge temperature of the compressor, lower discharge and suction pressure, lower current, and frost on the gas return pipe. These phenomena disappear when the system is replenished with normal refrigerant.

7.2.21 F75: Compressor discharge insufficient superheat protection

Digital display output

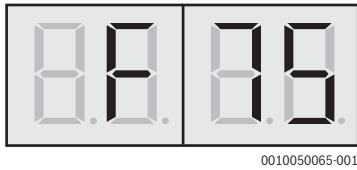

Description

- Superheat degree of compressor discharge temperature is too low, triggering protection shut down.
- Determination during operation of outdoor unit.
- All units stop running.
- The error code is displayed on the outdoor unit with error.

Trigger/recover condition

- Trigger condition: During the system operation, the discharge superheat of the compressor is lower than 6 °C and lasts for more than 90 minutes.
- Recover condition: Resume automatically after 30 seconds of downtime.
- Reset method: Resume automatically.

Possible causes

- Temperature sensor not connected properly or has malfunction.
- High pressure sensor not connected properly or has malfunction.
- Excess refrigerant.
- Some valves of outdoor unit can't be fully closed.
- Some valves of indoor unit can't be fully closed.
- Outdoor main control board damaged.

Procedure

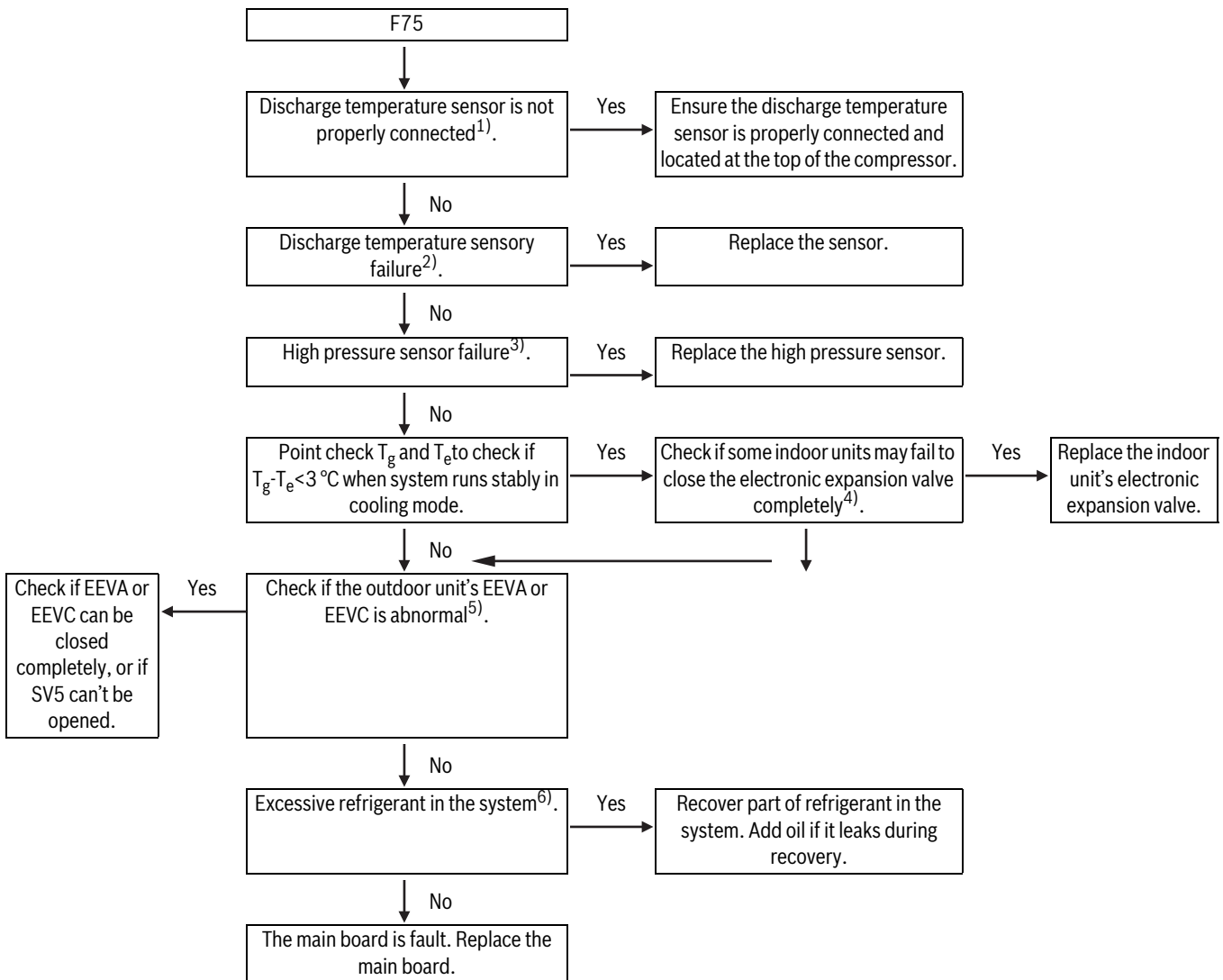

1) The main control board port of discharge temperature sensor 1 (T7C1) is CN4 and discharge temperature sensor 2(T7C2) is CN38.
 2) Measure sensor resistance. If the resistance is too low, the sensor has short-circuited. If the resistance is not consistent with the sensor's resistance characteristics table, the sensor has failed. Refer to Temperature Sensor Resistance Characteristics
 3) Measure the resistance among the three terminals of the pressure sensor. If the resistance is of the order of mega Ωs or infinite, the pressure sensor has failed.
 4) Close the indoor unit and check whether the temperature of the Gas pipe is too low or frosted or the evaporator is frosted.
 5) If the following happens the EEVA or EEVC of outdoor unit is abnormal: T6B -T6A<3 °C and T6A -T_e <3 °C when EEVC minimum opening (0pls or 17pls), or T8 -T_e <2 °C when EEVA minimum opening (0pls or 17pls) in heating mode.
 6) Excess refrigerant causes discharge temperature to be lower than normal, discharge pressure to be higher than normal, and suction pressure to be higher than normal.

7.2.22 P11: High pressure sensor error

Digital display output

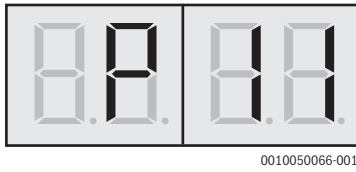

Description

- Open/short circuit error of high pressure sensor.
- All units stop running.

Procedure

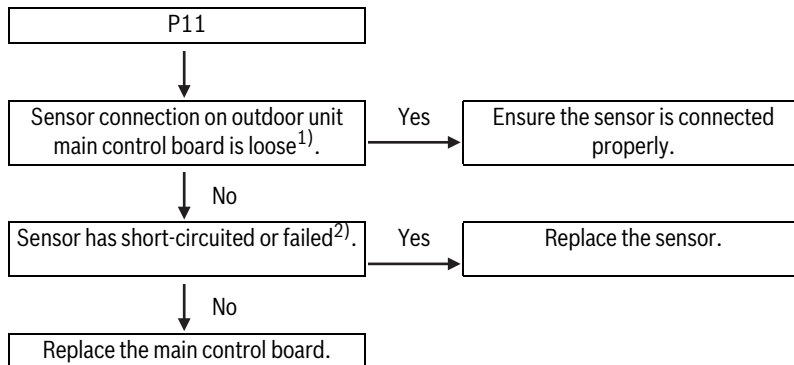

1) The ports on the main control board corresponding to the high-pressure pressure sensor are CN40, please refer to Main control board port definition.

2) Measure the voltage of the CN40 port. If the sensor is normal, use a multimeter to measure the port voltage. If the port voltage is not 3.3V after the main control board is powered on, the main control board is damaged and needs to be replaced.

- Error code is displayed on the outdoor unit with the error.

Trigger/recover condition

- Trigger condition: The main control board cannot obtain the normal AD value of the high pressure sensor
- Recover condition: The main control board can obtain the normal AD value of the high pressure sensor.
- Reset method: Resume automatically.

Possible causes

- The high pressure sensor is not properly connected to the main control board, or it fails.
- Main control board is damaged.

7.2.23 P12, P14: High pressure protection

Digital display output

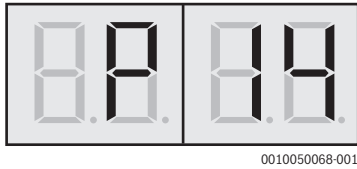
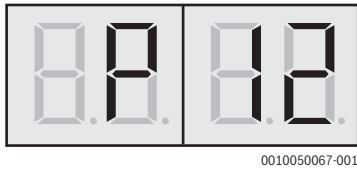

Description

- P12: The high pressure is over the limit.
- P14: 3 times P12 in 100 minutes.
- All units stop running.

Procedure

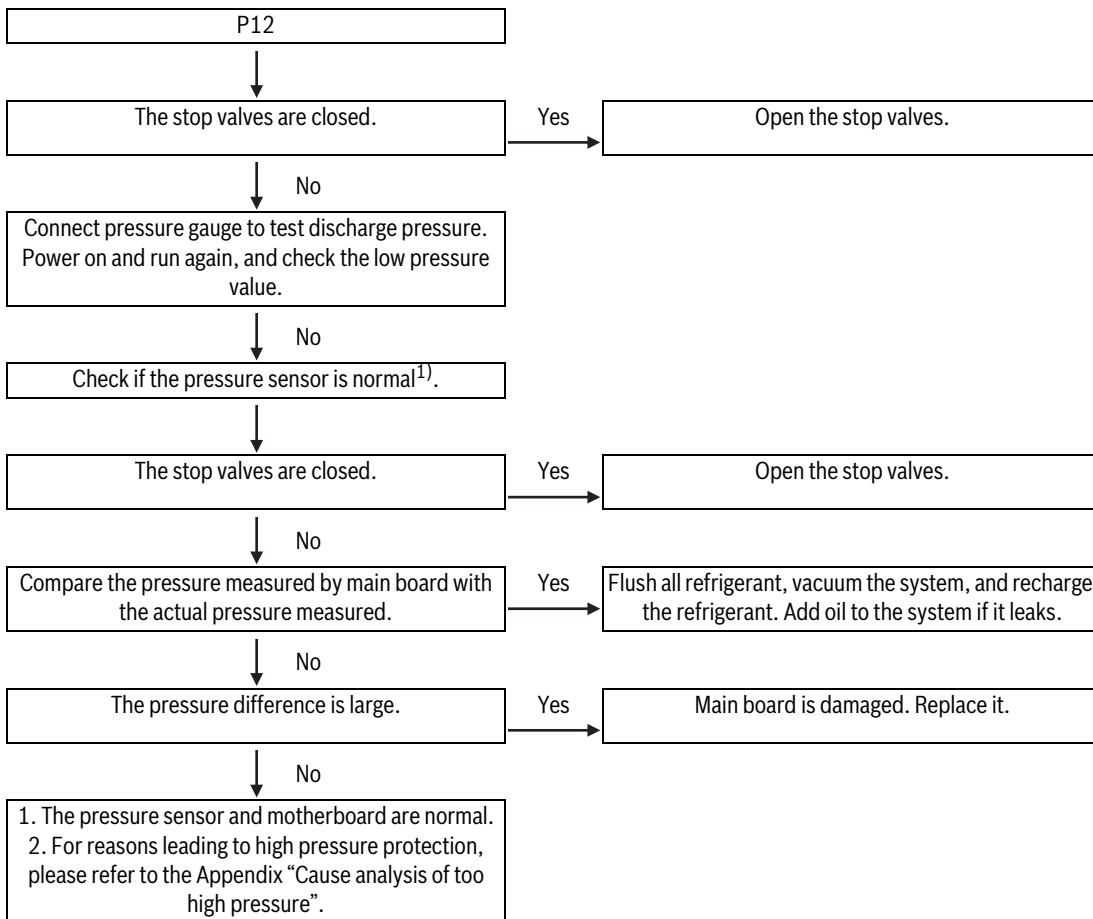

1) The high voltage sensor port is connected to the outdoor unit main control board port CN40.

- Error code is displayed on the unit with the error.

Trigger/recover condition

- Trigger condition:
 - P12: discharge pressure ≥ 4.15 MPa.
 - P14: P12 occurs 3 times within 100 minutes.
- Recover condition:
 - P12: Cooling mode: discharge pressure < 3.5 MPa.
 - P12: Heating mode: discharge pressure < 3.1 MPa.
 - P14: Remove high pressure protection from Outdoor Unit.
- Reset method:
 - P12: Resume automatically.
 - P14: Resume manually.

Possible causes

- Outdoor unit stop valves are closed.
- Pressure sensor/switch not connected properly or has malfunction.
- Poor condenser heat exchange.
- Outdoor main control board damaged.
- Refer to appendix "Cause analysis of excessive discharge pressure".

7.2.24 P13: High pressure switch protection

Digital display output

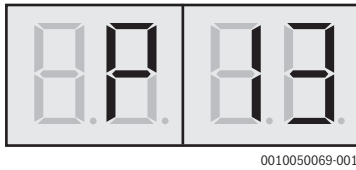

Description

- All units stop running.
- The error code is displayed on the unit with error.

Trigger/recover condition

- Trigger condition: Discharge pressure ≥ 4.2 MPa.
- Recover condition: Discharge pressure < 3.0 .
- Reset method: Resume automatically.

Possible causes

- Outdoor unit stop valves are closed.
- Pressure switch not connected properly or has malfunction.
- Excess refrigerant.
- System contains air or nitrogen.
- High pressure side blockage.
- Poor condenser heat exchange.
- Outdoor main control board damaged.

Procedure

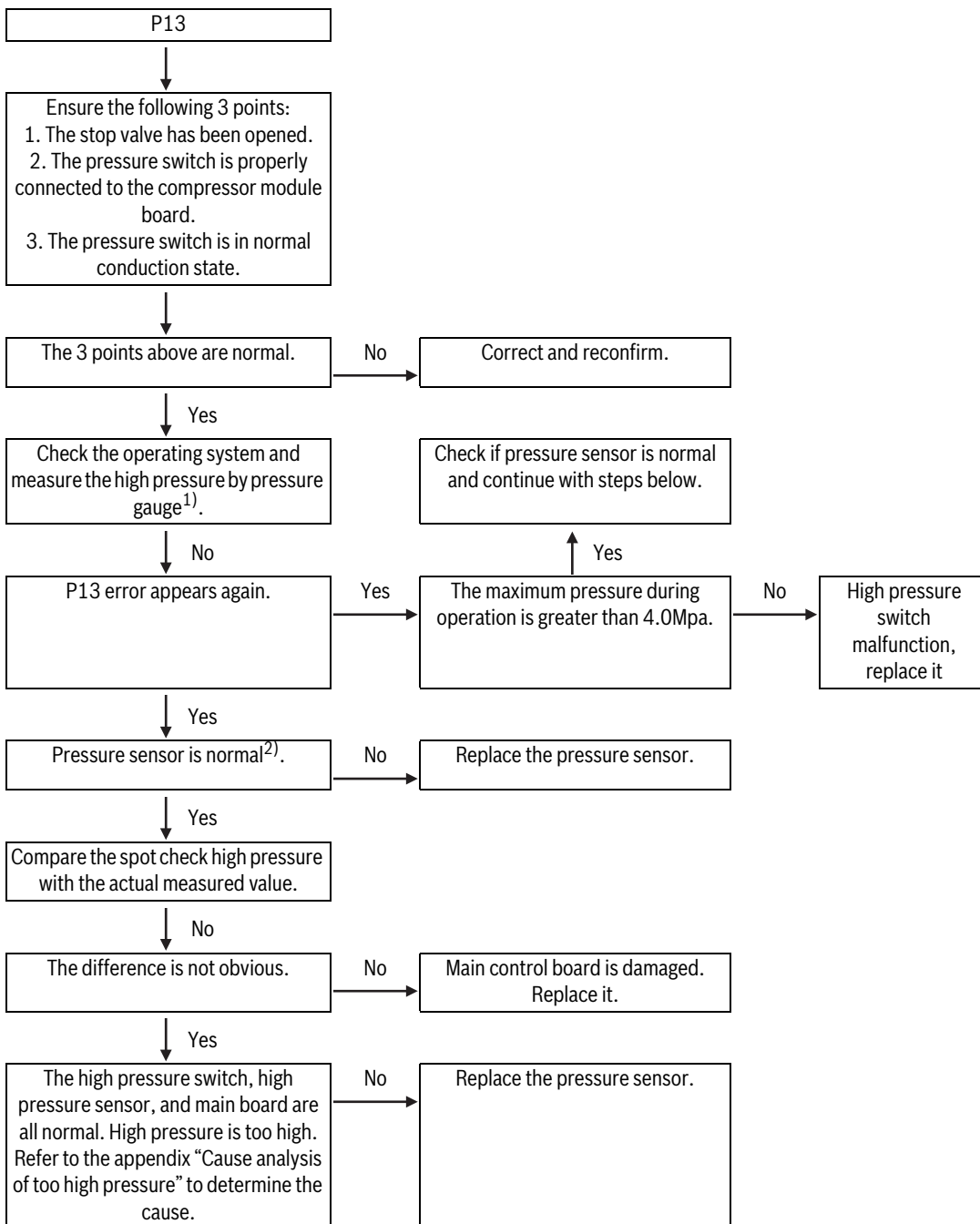

1) The high pressure switch port is connected to the outdoor unit inverter driver board port CN21.
 2) To check whether the pressure sensor is abnormal, refer to the Chapter "Pressure sensor detection".

7.2.25 P21: Low pressure sensor error

Digital display output

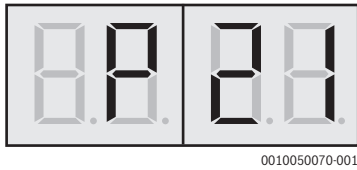

Description

- Open/short circuit error in suction pressure sensor.
- All units stop running.
- Error code is only displayed on the slave unit with the error.

Procedure

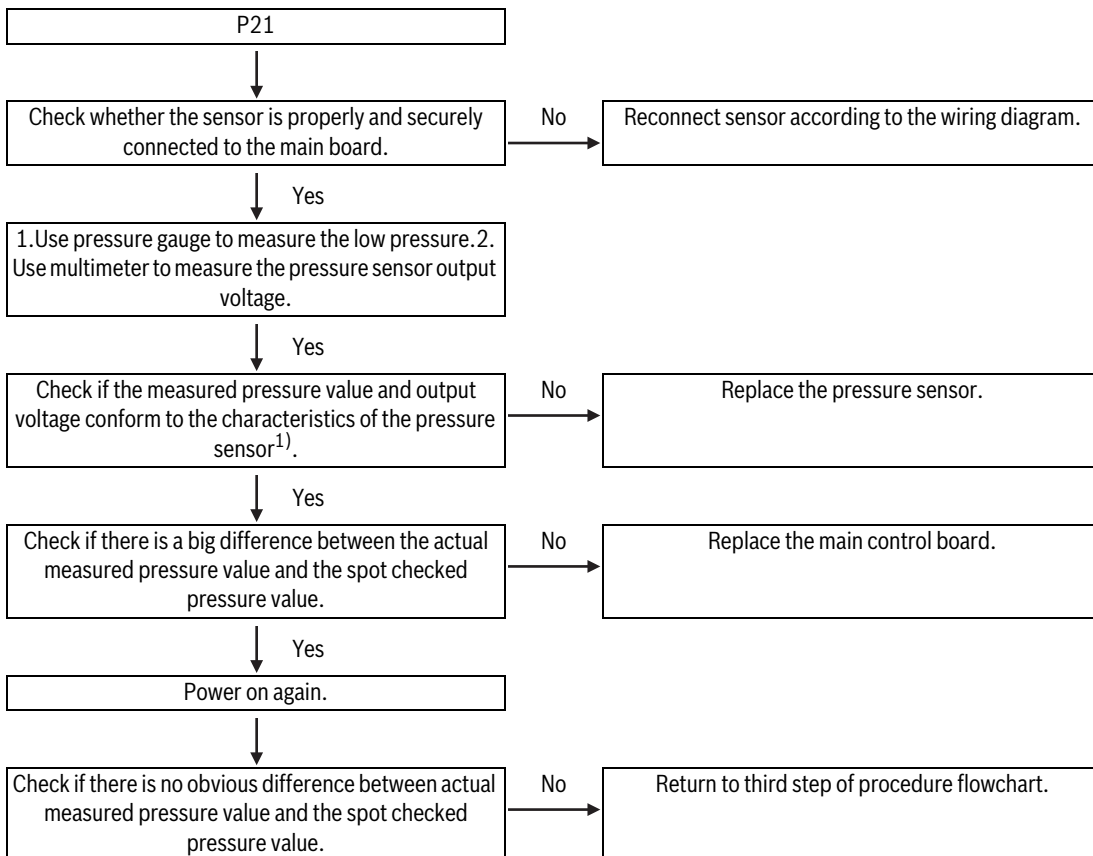

1) To check whether the pressure sensor is abnormal, refer to the appendix "Pressure sensor detection".

Trigger/recover condition

- Trigger condition: Abnormal values of the low-pressure sensor have been detected for 2 consecutive minutes.
- Recover condition: Rectify the error of the low-voltage sensor and power it on again.
- Reset method: Power it on again.

Possible causes

- Suction pressure sensor has poor contact or it is damaged.
- Main control board is damaged.
- The low pressure sensor is inversely connected to the high pressure sensor.

7.2.26 P22, P25: Low pressure protection

Digital display output

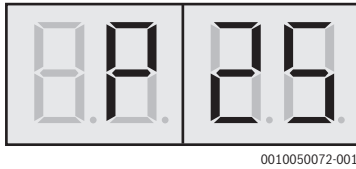
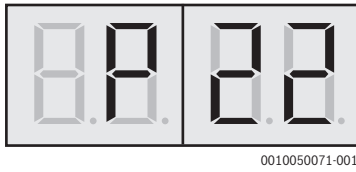

Description

- All units stop running.

Procedure

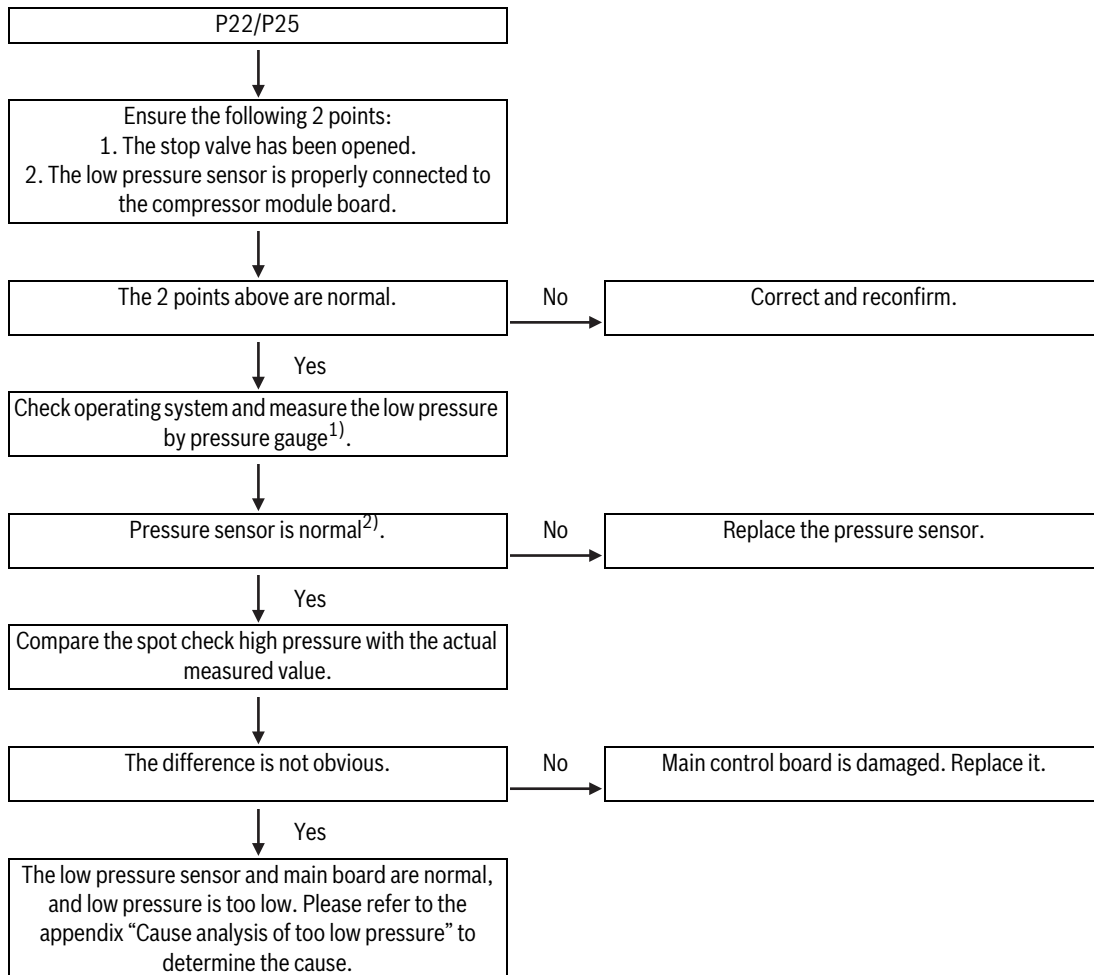

1) The low pressure sensor port is connected to the outdoor unit main control board port CN41.

2) To check whether the pressure sensor is abnormal, refer to the appendix "Pressure sensor detection".

- Error code is displayed on the unit with the error.

Trigger/recover condition

- Trigger condition:
 - P22: suction pressure < 0.07MPa.
 - P25: P22 occurs 3 times within 60 minutes.
- Recover condition: Suction pressure > 0.15MPa.
- Reset method:
 - P22: Resume automatically.
 - P25: Resume manually.

Possible causes

- Outdoor unit stop valves are closed.
- Low pressure sensor is damaged.
- Main control board of outdoor unit is damaged.
- The actual pressure is too low.

7.2.27 P24: Abnormal elevation of low pressure

Digital display output

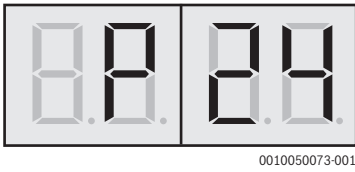

Description

- All units stop running.

Procedure

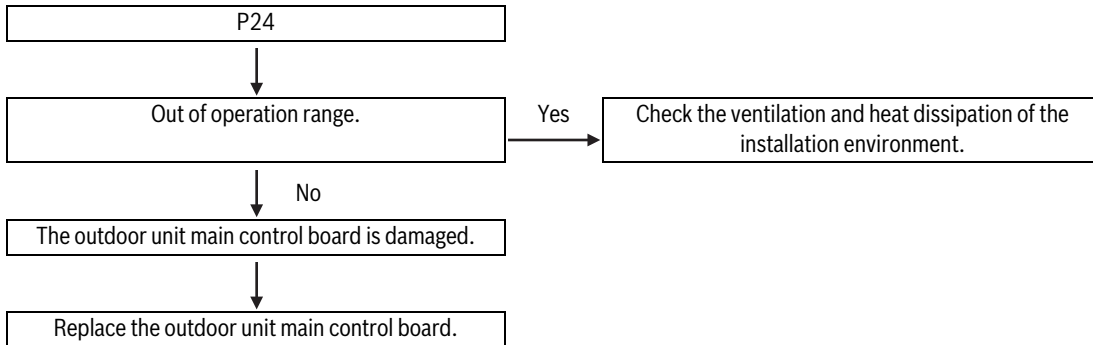

- Error code is displayed on the unit with the error.

Trigger/recover condition

- Trigger condition: Suction pressure >1.6MPa and lasts 60 minutes.
- Recover condition: The outdoor unit shuts down and resumes automatically after 1 minute.
- Reset method: Resume automatically.

Possible causes

- Outdoor unit out of range operation.
- Main control board of outdoor unit is damaged.

7.2.28 xP32, xP33: No.(x) compressor high DC bus current protection

Digital display output

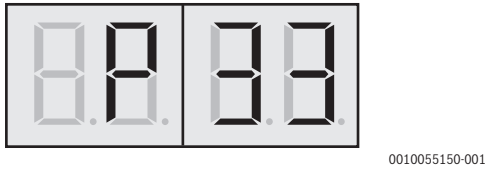

Description

- The DC bus current of No.x compressor is too high, triggering protection shut down.
- All units stop running.

Procedure

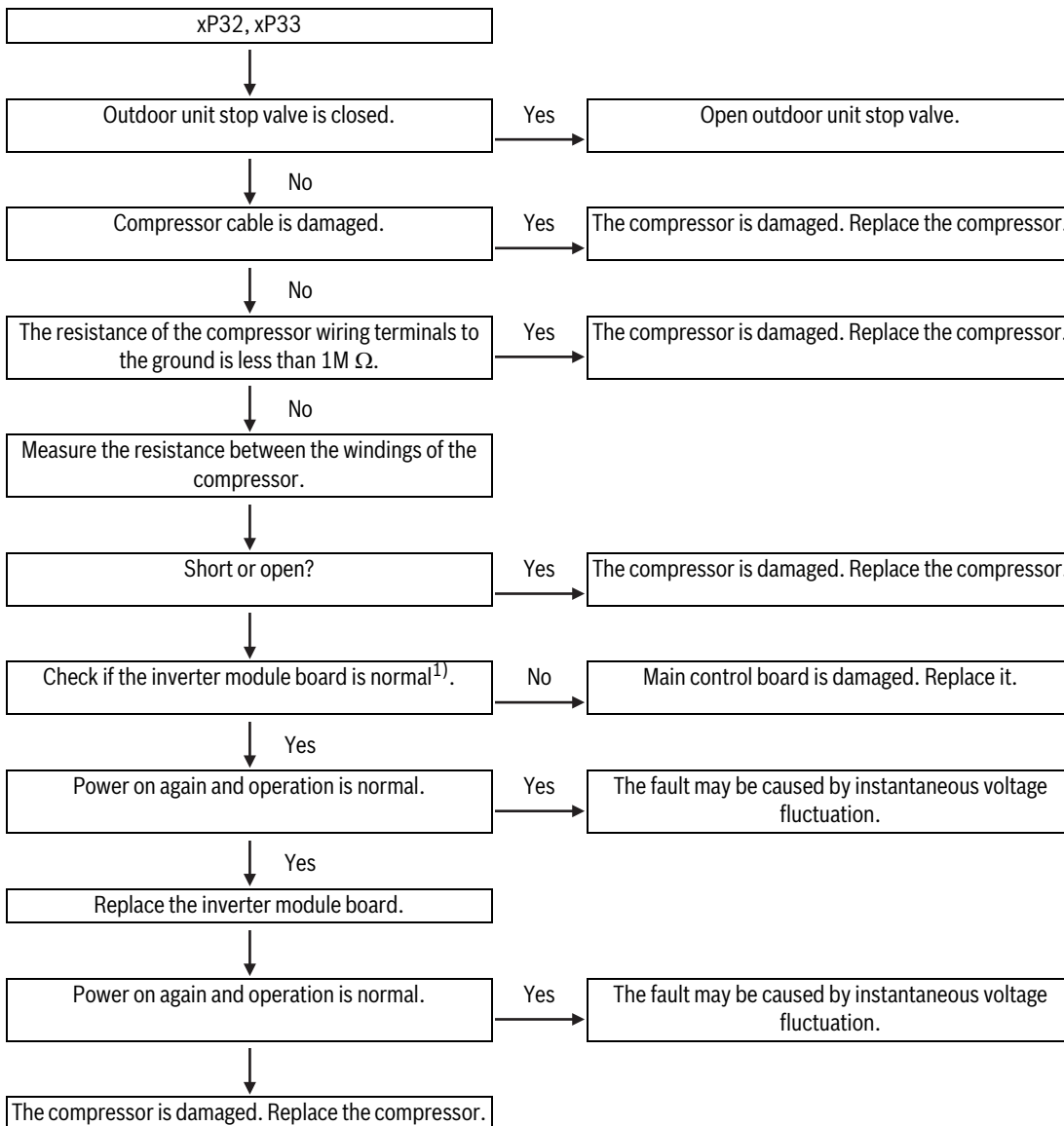

1) Refer to the appendix "Measurement guide for inverter module board".

- Error code is displayed on the unit with the error.

Trigger/recover condition

- Trigger condition:
 - P32: During operation, the DC bus current of any compressor .
 - P25: Within 100min, No.x compressor displays P32 3 times.
- Recover condition:
 - P32: The DC bus current of all compressors is lower than the recovery value.
 - P33: After the device is powered on again, release the lock.
- Reset method:
 - P32: Resume automatically.
 - P33: Resume manually.

Possible causes

- The compressor is overload.
- The motor coil inside the compressor is damaged and short-circuited.
- The high-pressure pipe side is blocked.
- The inverter module board is damaged.

7.2.29 P51: High AC voltage protection

Digital display output

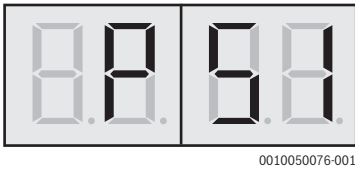

Description

- The AC voltage of the system is too high, triggering the protection shutdown.

Procedure

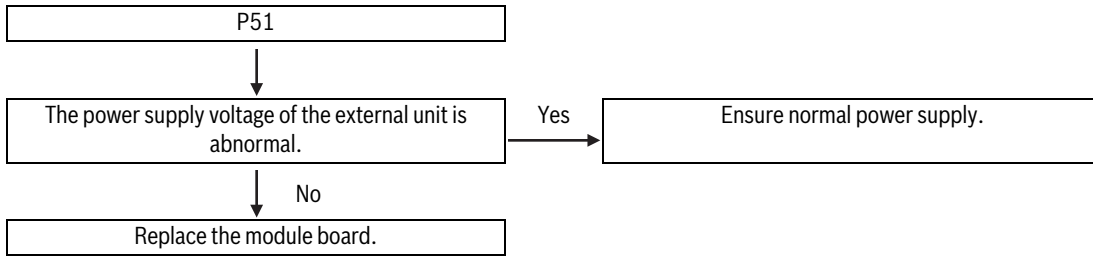

- All units stop running.
- Error code is displayed on the unit with the error.

Trigger/recover condition

- Trigger condition: The AC voltage of outdoor unit over 265 V.
- Recover condition: Wait 7/15/30min for each occurrence, and the AC voltage of outdoor unit drops below 250 V.
- Reset method: Resume automatically.

Possible causes

- The power supply voltage is too high.
- The module is damaged.

7.2.30 P52: Low voltage protection

Digital display output

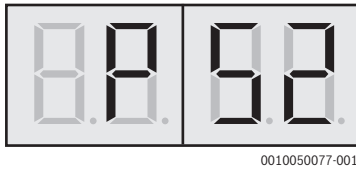

Description

- The AC voltage of the system is too low, triggering the protection shutdown.
- All units stop running.

Procedure

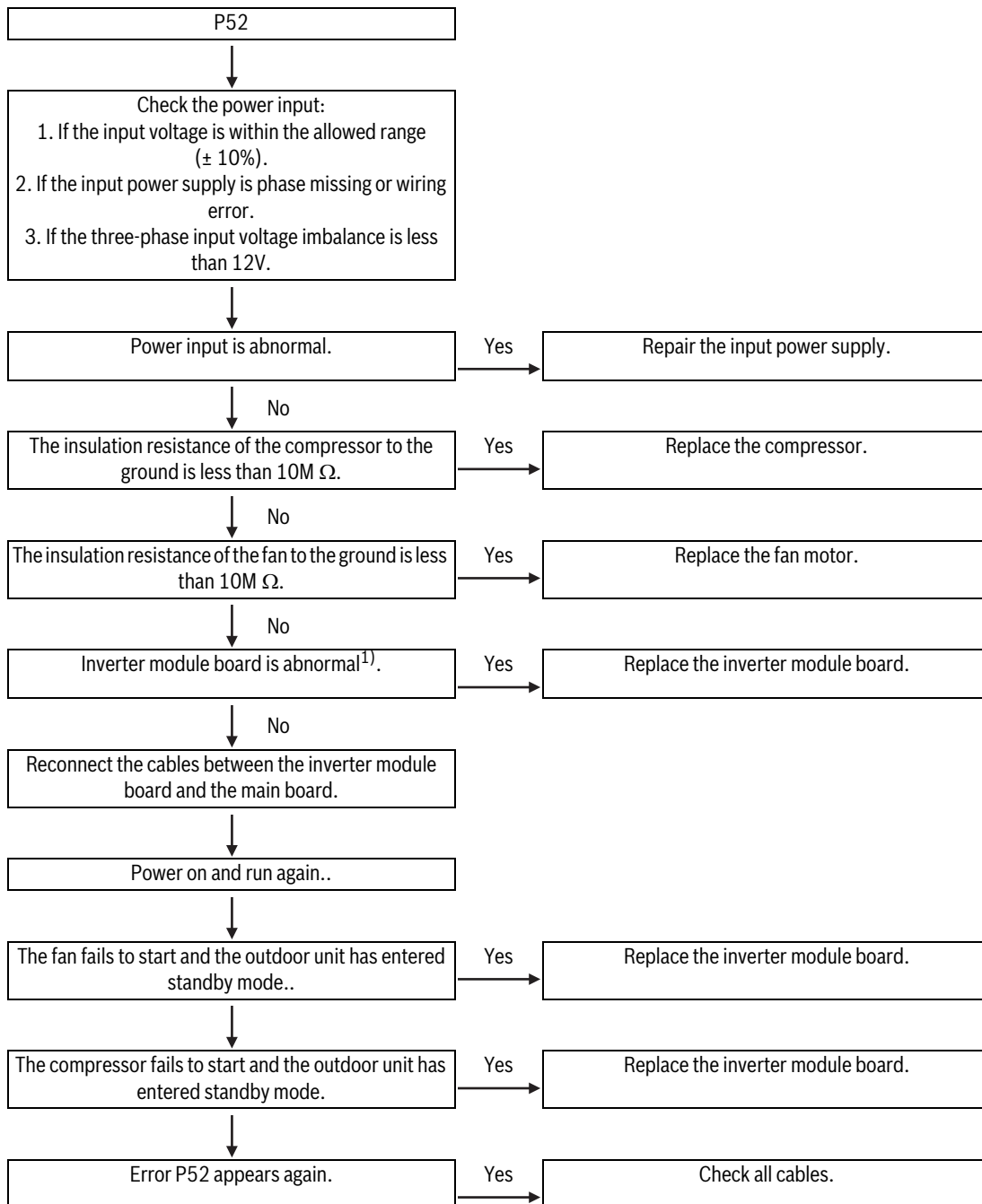

1) Refer to the appendix "Inverter module board detection".

- Error code is displayed on the unit with the error.

Trigger/recover condition

- Trigger condition: The Vac of the outdoor unit is less than 170 V.
- Recover condition: Wait 7/15/30min for each occurrence, and the Vac of Outdoor Unit rises above 180 V.
- Reset method: Resume automatically.

Possible causes

- The power supply voltage of the outdoor unit is abnormal or phase is missing.
- Cables in the electric control box are loose.
- Error in the high voltage circuit.
- The inverter driver board is damaged.

7.2.31 P53: Phase B and N of the power cable are connected to the opposite protection

Digital display output

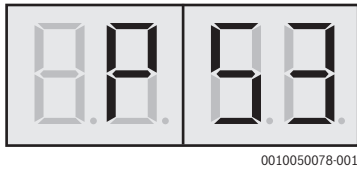

Description

- System zero line, phase line reverse connection.
- All units stop running.
- Error code is displayed on the unit with the error.

Trigger/recover condition

- Trigger condition: Phase B is connected to the zero line in reverse.
- Recover condition: Three-phase power phase sequence detection is correct.
- Reset method: Resume automatically.

Possible causes

- Outdoor unit power supply B N is inversely connected.
- Cables in the electric control box are loose.
- The inverter driver board is damaged.
- A phase or two of the system power supply has a large load, resulting in power supply voltage imbalance.
- The distribution phase imbalance of the grid exceeds 3% (phase Angle imbalance, or three-phase voltage imbalance, or both).

Procedure

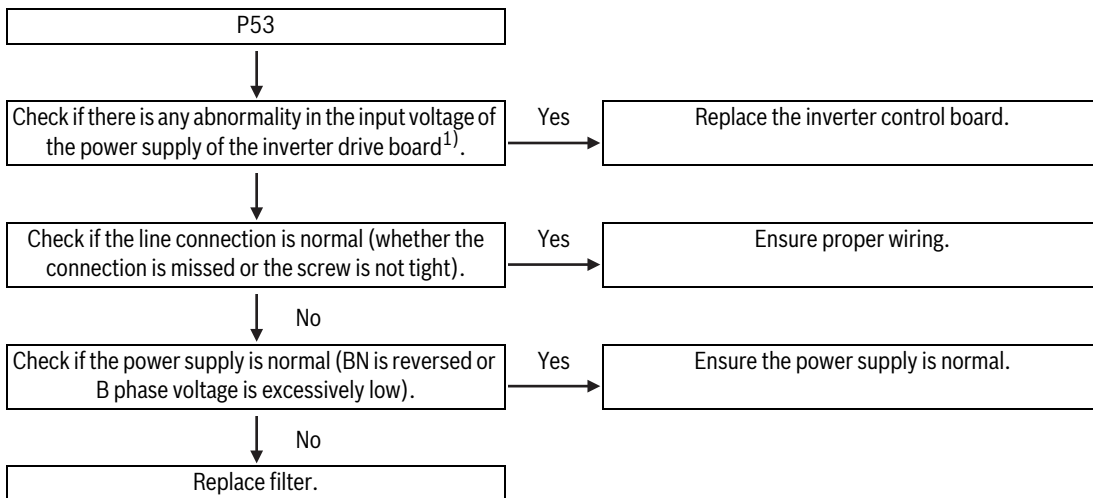

1) When the system is powered on, use a multimeter to measure the voltages of the power input terminals L1, L2, and L3 of the inverter drive board. Compare the voltages of L1-L2, L2-L3, and L1-L3. If nearly equal, the power supply voltage is fine. If there is a difference of more than 10V, consider the power phase imbalance. If there is a difference of tens or even hundreds of volts, consider the power supply or the filter board has a problem.

7.2.32 P54: DC bus low voltage protection

Digital display output

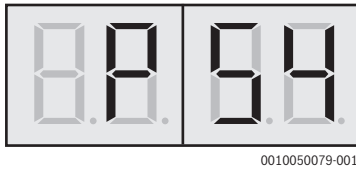

Description

- The DC bus voltage of the compressor is too low.
- All units stop running.
- Error code is displayed on the unit with the error.

Procedure

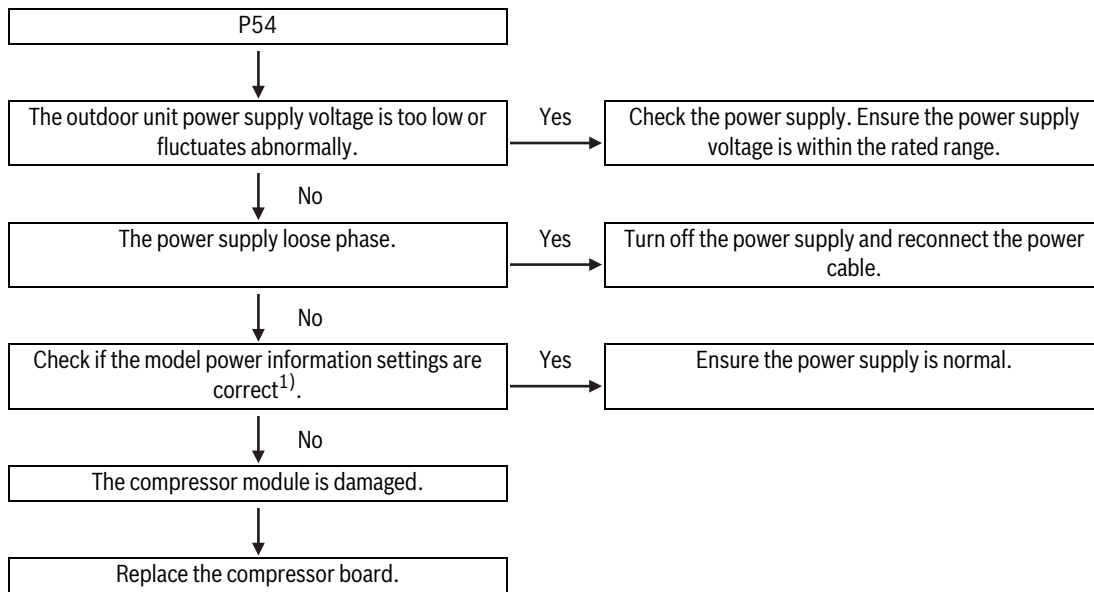

1) According to the power supply parameters.

Trigger/recover condition

- Trigger condition: The DC bus voltage of the outdoor unit is lower than the threshold.
- Recover condition: The DC bus voltage of the external unit is recovered above the threshold.
- Reset method: Resume automatically.

Possible causes

- The input voltage is too low.
- The power supply loose phase.
- The model power supply information is incorrectly configured.
- Inverter driver board is damaged.

7.2.33 P55: DC bus ripple over protection

Digital display output

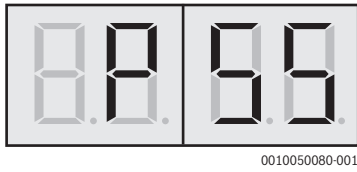

Description

- The ripple of the Dc bus on the module is over the limits.
- All units stop running.
- The error code is displayed on the unit with error.

Procedure

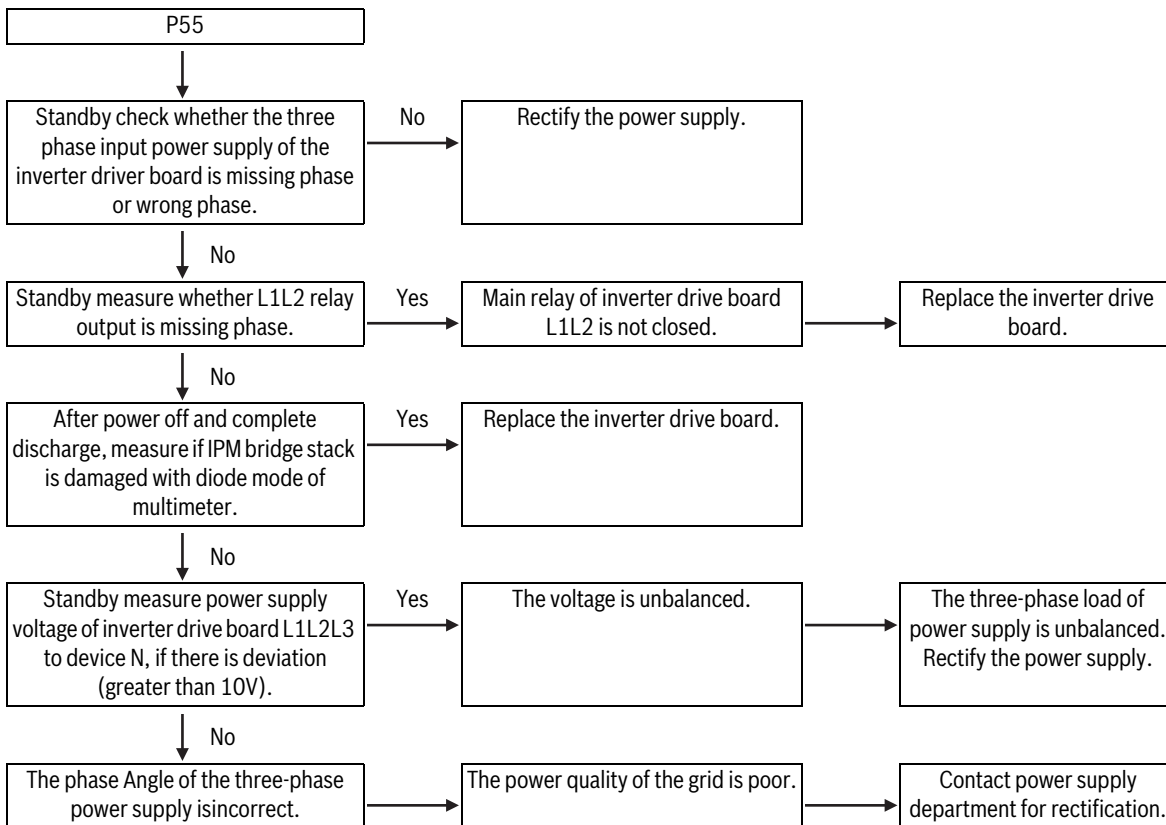

Trigger/recover condition

- Trigger condition: Power input is out of phase or the three-phase power supply is seriously unbalanced.
- Recover condition: Three-phase power supply without phase loss.
- Reset method: Resume automatically when fault exit condition reached.

Possible causes

- The outdoor unit power supply is out of phase or seriously unbalanced.
- Cables in the electric control box are loose.
- Inverter driver board is damaged.
- Power supply is abnormal.

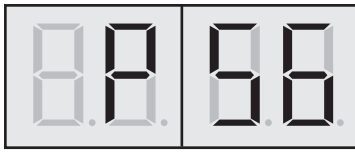
7.2.34 xP56: No.x inverter driver board DC bus voltage is too low**Digital display output**

0010055148-001

Description

- No.x inverter driver board DC bus voltage is too low.
- All units stop running.
- The error code is displayed on the unit with error.

Trigger/recover condition

- Trigger condition: The inverter driver board upload L3E/J3E fails.
- Recover condition: The inverter driver board does not upload L3E/J3E fails.
- Reset method: Resume automatically.

Possible causes

- The outdoor unit power supply is too low or phase is missing.
- Cables in the electric control box are loose.
- Inverter driver board is damaged.

Procedure

Troubleshoot according to J3E/L3E.

7.2.35 xP57: No.x inverter driver board DC bus voltage is too high

Digital display output

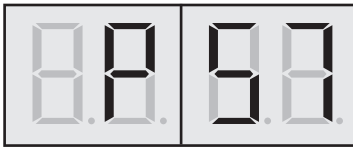

0010050082-001

Description

- No.x inverter driver board DC bus voltage is too high.
- All units stop running.
- The error code is displayed on the unit with error.

Trigger/recover condition

- Trigger condition: The inverter driver board upload L31/J31 fails.
- Recover condition: The inverter driver board does not upload L31/J31 fails.
- Reset method: Resume automatically.

Possible causes

- The outdoor unit power supply is too high.
- Inverter driver board is damaged.

Procedure

Troubleshoot according to J31/L31.

7.2.36 xP58: No.x inverter driver board DC bus voltage is excessively high

Digital display output

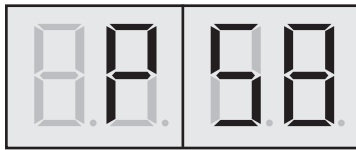

0010055146-001

Description

- No.x inverter driver board DC bus voltage is too high.
- All units stop running.
- The error code is displayed separately on each outdoor unit.

Trigger/recover condition

- Trigger condition: The inverter driver board upload L32/J32 fails.
- Recover condition: The inverter driver board does not upload L32/J32 fails.
- Reset method: Resume automatically.

Possible causes

- The input voltage is too high, resulting in the high DC bus voltage.
- The power grid voltage is too high.
- Inverter driver board is damaged.

Procedure

Troubleshoot according to J32/L32.

7.2.37 P71: Error in EEPROM

Digital display output

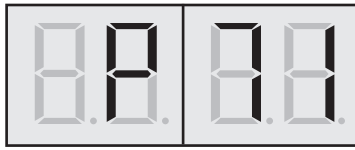

0010050084-001

Description

- The EEPROM parameter of the outdoor unit's main control board is incorrect.
- All units stop running.
- The error code is displayed on the unit with the error.

Trigger/recover condition

- Trigger condition: EEPROM parameter verification is incorrect.
- Recover condition: EEPROM parameter verification is correct.
- Reset method: Resume manually.

Possible causes

- EEPROM units damaged.
- Main control board is damaged.

Procedure

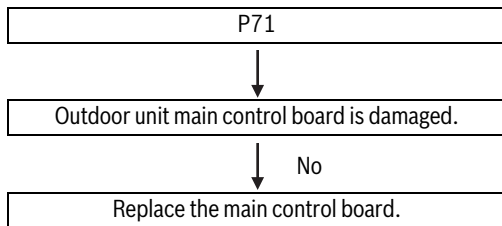

7.2.38 Pb1: SuperLink over-current error

Digital display output

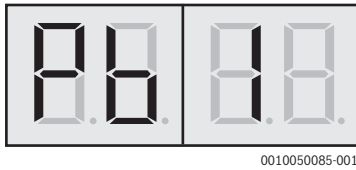

Description

- SuperLink over-current error.
- All units stop running.
- The error code is displayed on outdoor unit.

Trigger/recover condition

- Trigger condition: No indoor unit is in power down mode and the feedback voltage of the SuperLink board is > 1.5V for 120ms.
- Recover condition: SuperLink board feedback voltage < 0.2V.
- Reset method: Fault time < 2 hours, automatic recovery; If the fault time > 2 hours, power on again.

Possible causes

- The M1M2 communication line of the outdoor unit is short-circuited.
- The M1M2 communication line of the outdoor unit is connected to other communication line (not M1M2) of the indoor unit.
- The M1M2 communication line of the outdoor unit is connected to port TO DOWN indoor unit of the repeater.
- Main control board is damaged.

Procedure

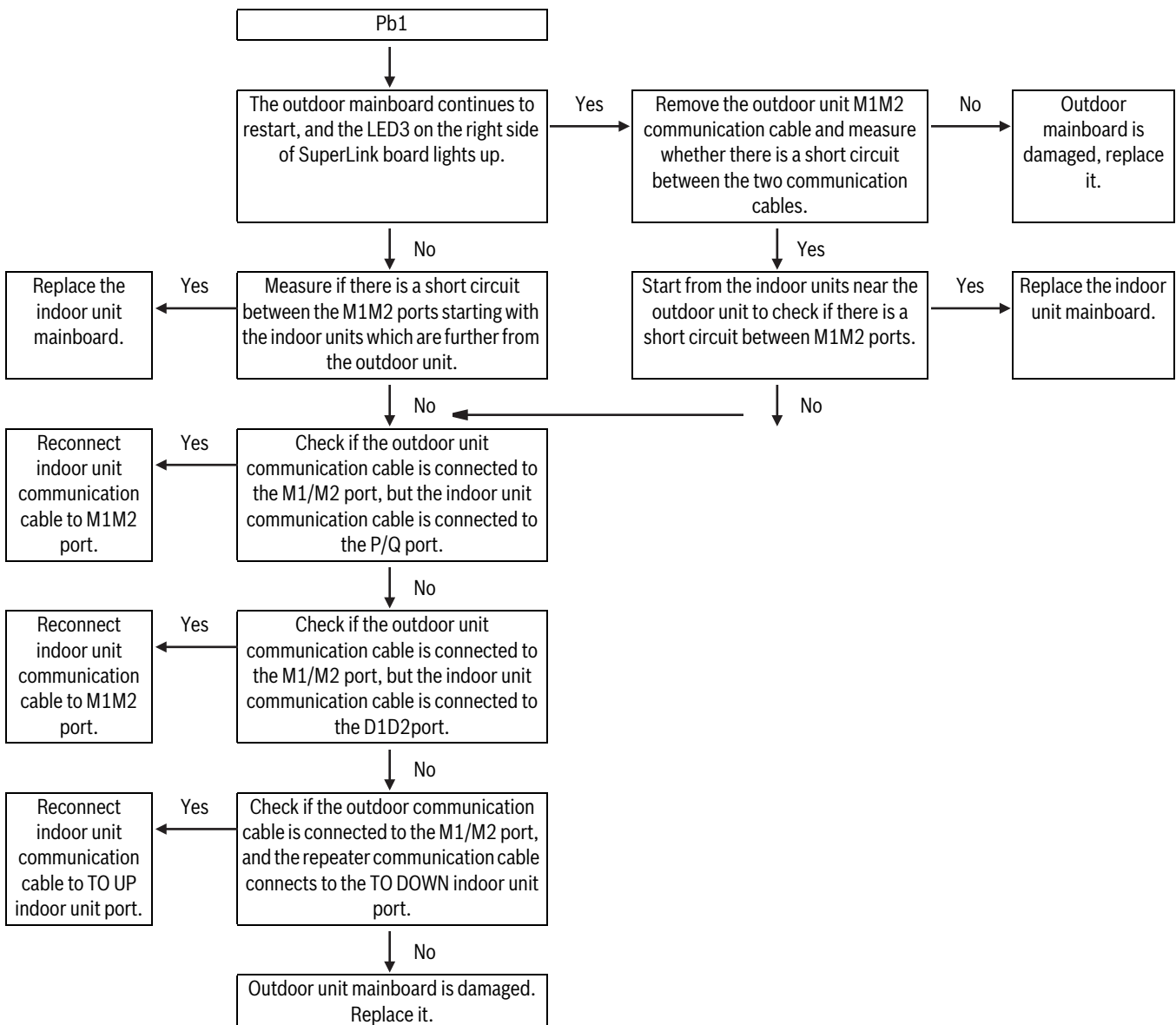

7.2.39 Pd1, Pd2: Anti-condensation protection

Digital display output

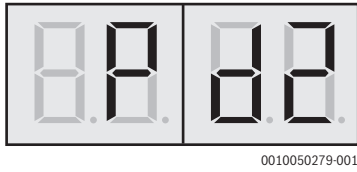
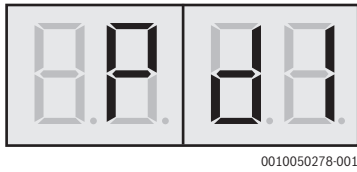

Description

- Anti-condensation protection.
- All units stop running.

Procedure

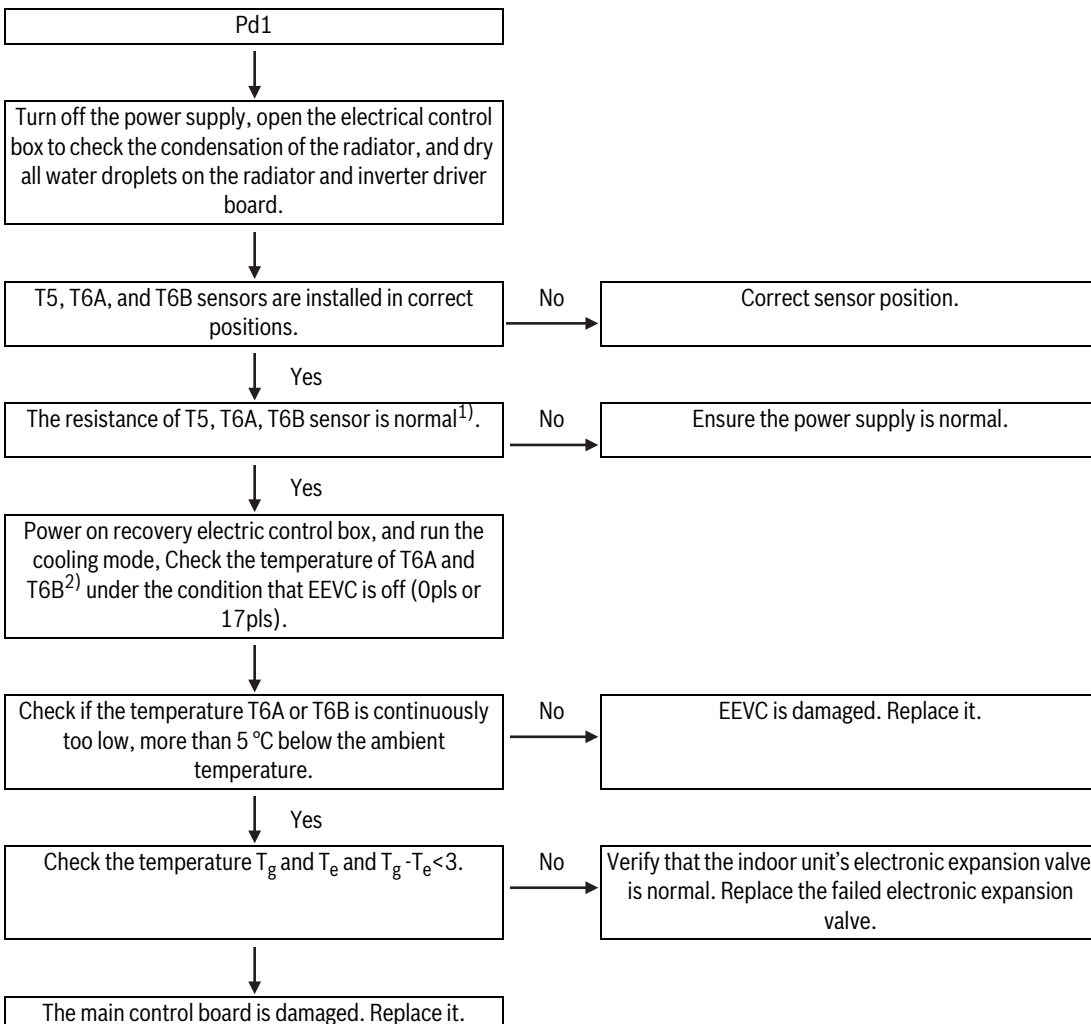

1) Refer to Temperature sensor resistance characteristic.
 2) Refer to the Digital display and button settings.

- Error code is displayed on the unit with the error.

Trigger/recover condition

- Trigger condition:
 - Pd1: The outlet temperature of Microchannel heat exchanger is below the dew point temperature for more than 10 minutes.
 - Pd2: Pd1 protection occurs 2 times in 60 minutes.
- Recover condition: The outlet temperature of Microchannel heat exchanger is higher than the dew point temperature.
- Reset method: Power on again.

Possible causes

- Temperature sensors T6A, T6B, and T5 are not installed in the correct positions.
- Temperature sensor T6A, T6B, and T5 are damaged.
- Electronic expansion valve EXVC cannot be fully closed.
- The internal electronic expansion valve is too open or cannot be adjusted.
- Main control board is damaged.

7.2.40 xb01: The electronic expansion valve is in error

Digital display output

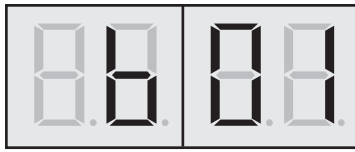

0010055145-001

Description

- No. x electronic expansion valve's connection on main control board is missing (1 to 4 correspond to expansion valves A, B, C, and E respectively).
- All units stop running electronic.

Procedure

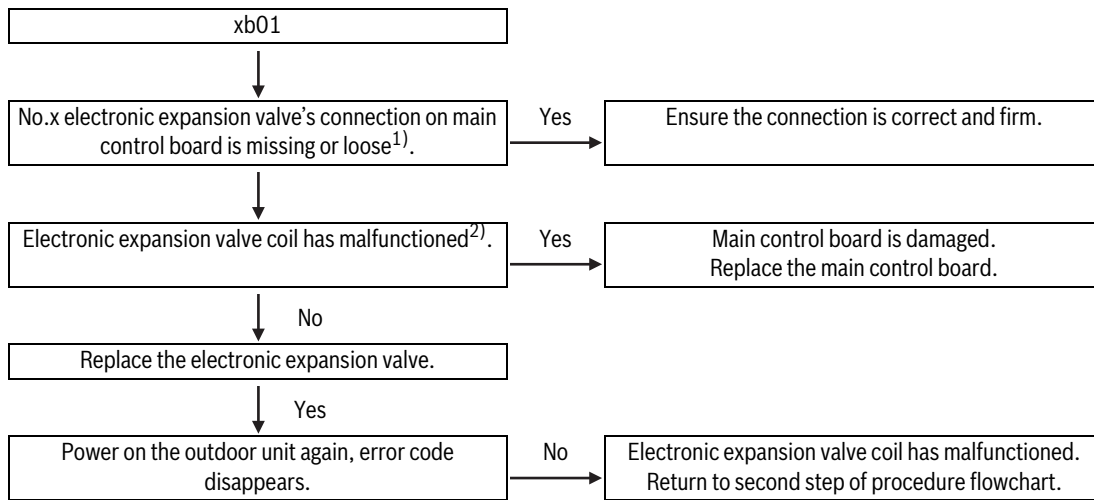

1) All outdoor unit models have electronic expansion valves A and C, which are connected to the main boards CN70 and CN72. Some models have electronic expansion valves B and E with CN71 and CN73 ports.

2) Schematic diagram of coil resistance measurement of electronic expansion valve and reference range of resistance:

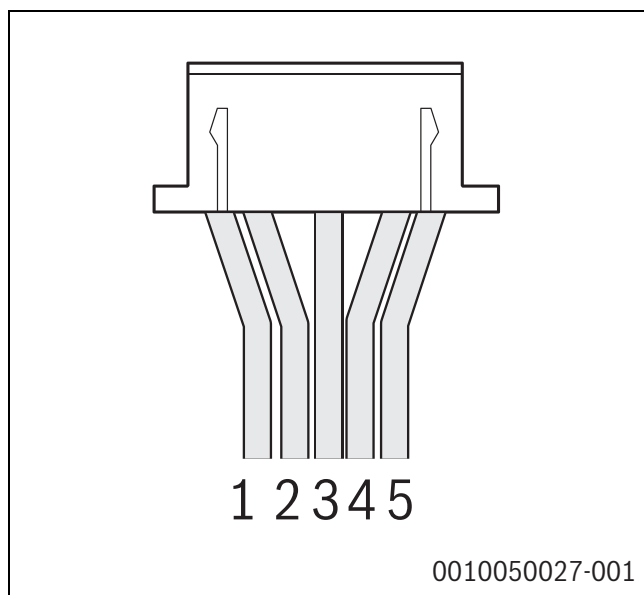

Fig. 45

0010050027-001

- Error code is displayed on the outdoor unit with the error.

Trigger/recover condition

- Trigger condition: After the system is powered on, the outdoor unit cannot detect the signal of electronic expansion valve within 2 minutes.
- Recover condition: After the system is powered on again, the outdoor unit can detect the signal of electronic expansion valve.
- Reset method: Resume manually, and power on again.

Possible causes

- Electronic expansion valve is not connected to main control board correctly.
- The electronic expansion valve coil is damaged.
- Main control board is damaged.

Side Flow Series			
Measurement point	resistance	resistance	resistance
1-5	40-50 Ω	40-50 Ω	90-110 Ω
2-5	40-50 Ω	40-50 Ω	90-110 Ω
3-5	40-50 Ω	40-50 Ω	90-110 Ω
4-5	40-50 Ω	40-50 Ω	90-110 Ω

Side Flow Series			
Model capacity range	25-45kW	45-90kW	
The body coil	Valve A/C/E	Valve C/E	Valve A

7.2.41 U11: Outdoor unit model is not set

Digital display output

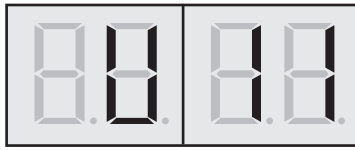

0010050087-001

Description

- All units stop running.
- The error code is displayed on the unit with the error.

Trigger/recover condition

- Trigger condition: The model information is not set.
- Recover condition: The model information of the unit is set correctly.
- Reset method: Resume manually.

Possible causes

- The model information is not set.

Procedure

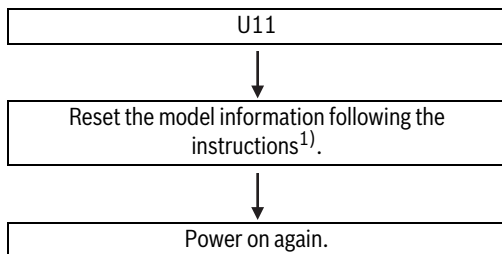

1) Use the Bluetooth module or Bluetooth after-sales kit.

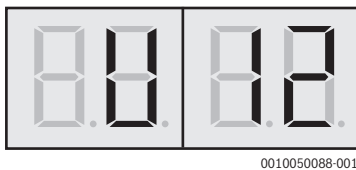
7.2.42 U12: Outdoor unit capacity setting error**Digital display output****Description**

- The capability information of outdoor unit is not set.
- All units stop running.
- The error code is displayed on the unit with the error.

Trigger/recover condition

- Trigger condition: The outdoor unit's capability information is not set.
- Recover condition: Reset the outdoor unit's capability information.
- Reset method: Resume manually.

Possible causes

- The outdoor unit's capability information is not set.

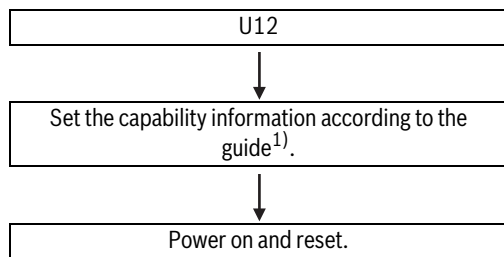
Procedure

1) Set the capability information according to the nameplate.

7.2.43 U21: The indoor unit connection is incorrect

Digital display output

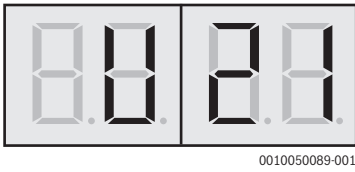

Description

- The indoor unit’s connection is incorrect.
- All outdoor units stop running.
- Error is only displayed in main control board.

Trigger/recover condition

- Trigger condition:
 - The following devices can be connected to the VRF system:*
 - Standard air-cooled indoor units
 - AHU KIT
 - Hydraulic module
 - The following join combinations are allowed:*
 - VRF Indoor Unit + AHU KIT
 - VRF Indoor Unit + Hydraulic module
 - VRF Indoor Unit
- *Apart from the above three combination modes, the system detects the combination of indoor units and reports the following failure prompt:*
 - Error code: The system checks the connected indoor unit type
 - U21: The system is connected to the old indoor unit
- Recover condition: Correct indoor unit assembly is detected.
- Reset method: Resume manually.

Possible causes

- The indoor unit assembly does not meet the requirement.

Procedure

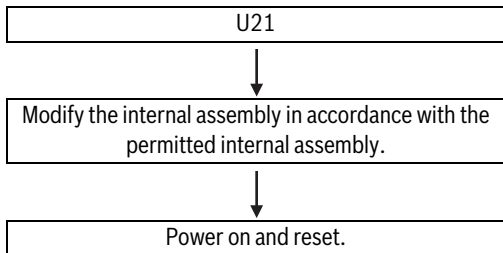

7.2.44 U31: The test run was never successful

Digital display output

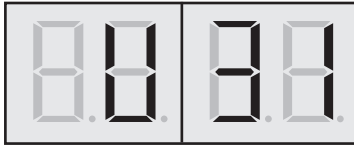

0010050090-001

Description

- The test run was unsuccessful.
- All units stop running.
- The error code is only displayed on the outdoor unit.

Trigger/recover condition

- Trigger condition: The test run was unsuccessful.
- Recover condition: The test run was completed successfully.
- Reset method: Resume manually.

Possible causes

- The test run was unsuccessful.

Procedure

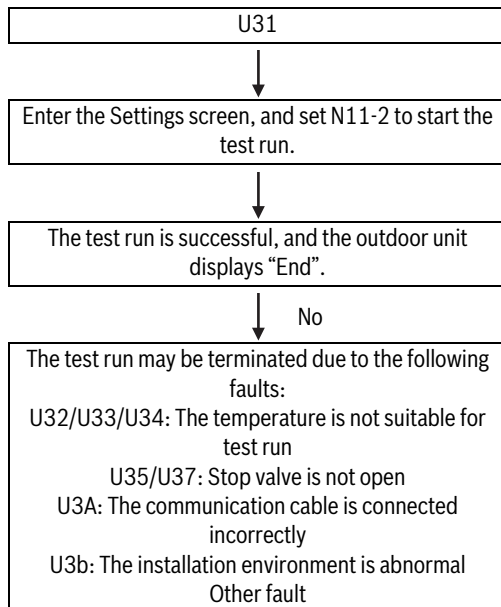

7.2.45 U32, U33, U34: The temperature is not suitable for test run

Digital display output

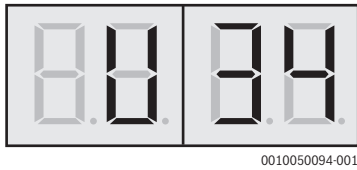
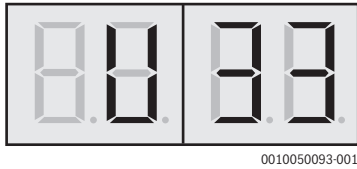
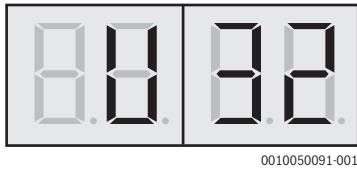

Description

- Ambient temperature is out the allowed range of test run.
- All units stop running.
- Error code is only displayed on outdoor unit.

Trigger/recover condition

- Trigger condition: After entering into test run, the outdoor unit estimates whether it is suitable for test run according to the indoor average return air temperature T1 and outdoor average ambient temperature T4 (refer to the figure and table below). If it is not suitable for test run, the outdoor unit displays an error code such as “U32, U33, U34”.

Procedure

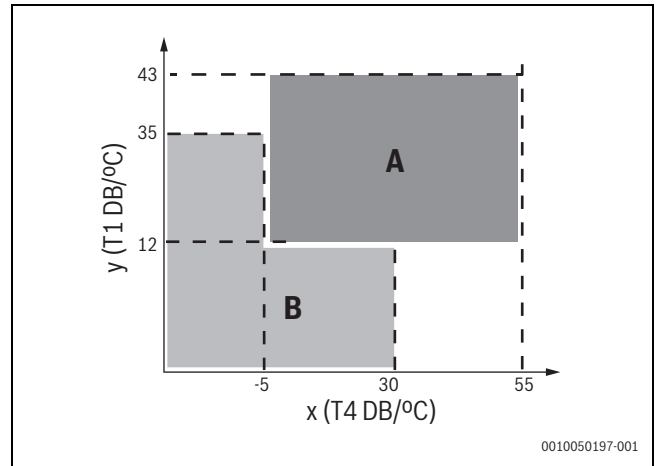
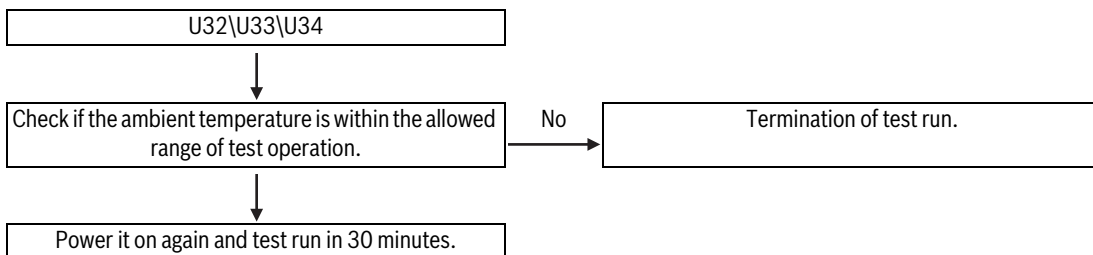

Fig. 46 Ambient temperature range of test run

- y Indoor return air temperature T1 BD/°C
- x Outdoor ambient temperature T4 BD/°C
- A Cooling mode
- B Heating mode

Error code	Description	
U32	The outdoor temperature is not suitable	Average T1 < -12 °C: T4min > 30 °C or T4min < -30 °C Average T1 ≥ 12 °C: T4min > 55 °C or T4min < -30 °C
U33	The indoor temperature is not suitable	T4min ≤ -5 °C: Average T1 > 35 °C T4min ≥ -5 °C: Average T1 > 43 °C
U34	The indoor and outdoor temperature is not suitable	Average T1 > 43 °C and T4min > 55 °C

- Recover condition: Press the “OK” button on the main control board for 5 seconds to exit the rest run.
- Reset method: Resume manually.

Possible causes

- The temperature is out of test run range.

7.2.46 U35, U37: Stop valve is not open

Digital display output

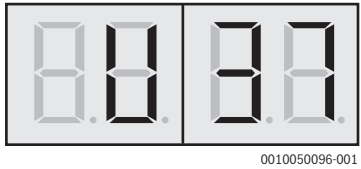
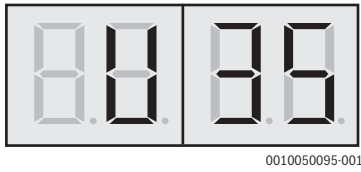

Description

- Stop valve is not open.
- All units stop running.
- Error code is only displayed on outdoor unit.

Trigger/recover condition

- Trigger condition:

Error code	Description	
U35	The liquid side stop valve of the system is not opened	Discharge pressure of heating mode $\geq 3.9\text{MPa}$
U37	The gas side stop valve of the system is not opened	Suction pressure of cooling mode $< 0.12\text{MPa}$

- Recover condition: Press the “OK” button on the main control board for 5 seconds to exit the rest run.
- Reset method: Resume manually.

Possible causes

- Stop valve is not open

Procedure

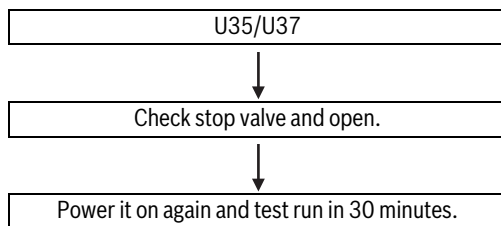

7.2.47 U3A: The communication cable is connected incorrectly

Digital display output

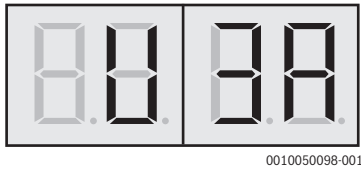

Description

- There are indoor units in the communication system outside the refrigerant system.
- All outdoor units stop running.
- Error is only displayed on the outdoor unit.

Trigger/recover condition

- Trigger condition: There are indoor units in the communication system outside the refrigerant system.
- Recover condition: Press the "OK" button on the main board for 5 seconds to exit the test run.
- Reset method: Resume manually.

Possible causes

- There are indoor units in another refrigerant system connected with outdoor unit by communication cable.

Procedure

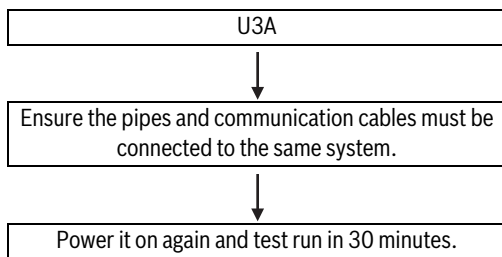

7.2.48 U3b: The installation environment is abnormal

Digital display output

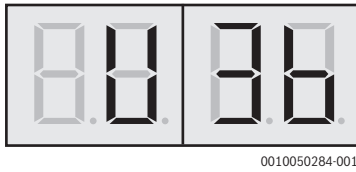

Description

- During the test run, abnormal changes in ambient temperature are detected and the operation is stopped.
- All units stop running.
- Error code is only displayed on the outdoor unit.

Trigger/recover condition

- Trigger condition:
 - Cooling mode: An increase of more than 10 °C in the return air temperature is detected during test run.
 - Heating mode: A decrease of more than 10 °C in the return air temperature is detected during test run.
- Recover condition: Press the “OK” button on the main board for 5 seconds to exit the test run.
- Reset method: Resume manually.

Possible causes

- The installation environment of the indoor unit has poor ventilation and heat dissipation, and the outlet air and return air form short circuit.
- Return air of the indoor unit is affected by other heat sources.
- The return air temperature sensor of the indoor unit is improperly installed or damaged.

Procedure

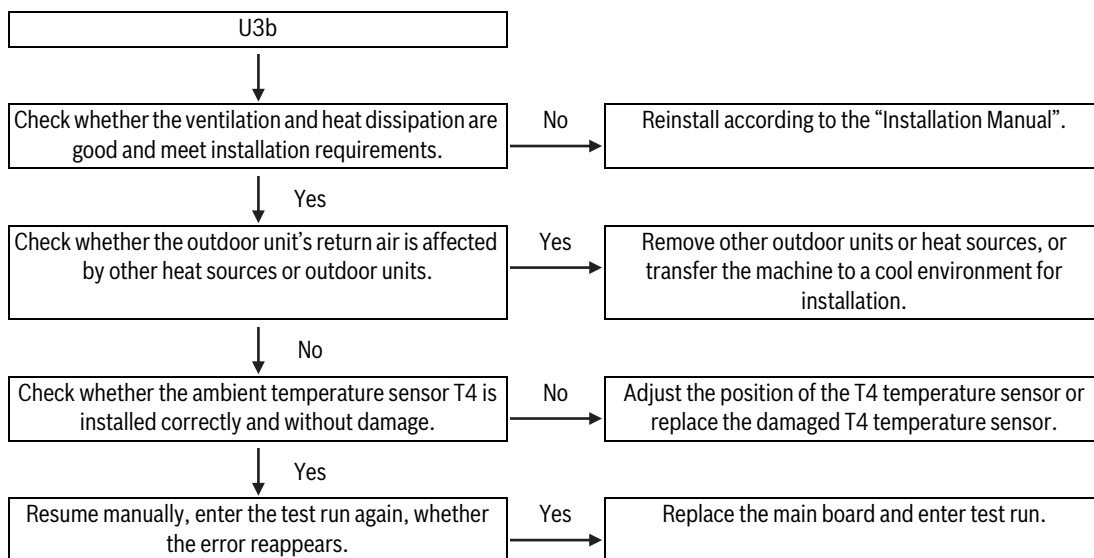

7.2.49 U3C: Changeover mode error

Digital display output

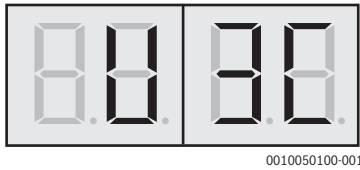

Description

- The outdoor unit in changeover mode doesn't detect the signal of VIP indoor unit.
- Outdoor units stop running.
- Error code is only displayed on the outdoor unit.

Procedure

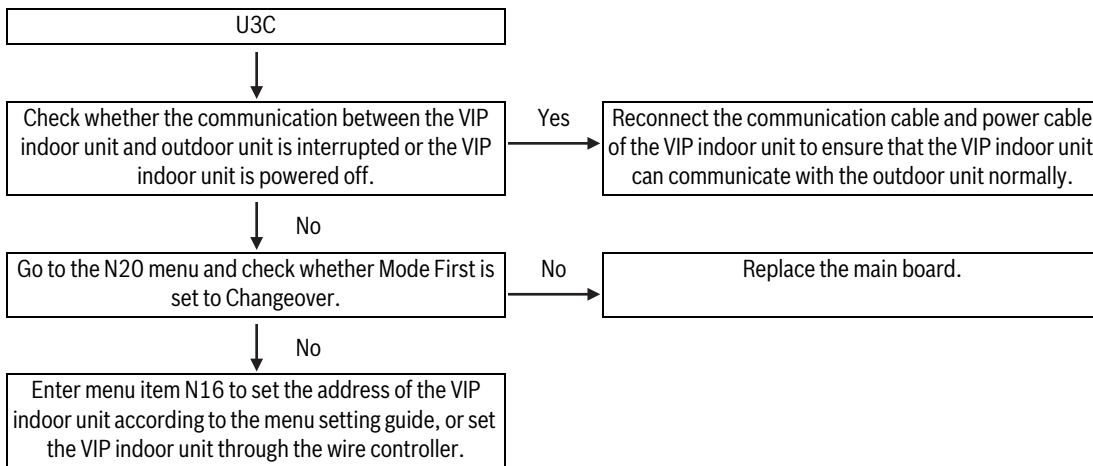

Trigger/recover condition

- Trigger condition:
 - The outdoor unit is in changeover mode, but the VIP address has not been set.
 - The VIP address has been set, but the outdoor unit in changeover mode doesn't detect the signal of the VIP indoor unit.
- Recover condition: The outdoor unit in changeover mode detects the signal of the VIP indoor unit.
- Reset method: Resume automatically.

Possible causes

- The VIP address has not been set.
- The communication between the VIP indoor unit and outdoor unit is abnormal.
- The main board of the outdoor unit is damaged.

7.2.50 U4x: Over-connection ratio

Digital display output

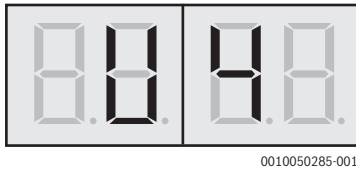

Description

- Protection over-connection ratio.
- All units stop running.

Trigger/recover condition

- Trigger condition:
 - Indoor unit code and type analysis, and connection ratio computing method:

Indoor unit code	Indoor unit type
Indoor unit A	VRF Air-cooled indoor unit
Indoor unit B	Fresh air processing unit
Indoor unit C	AHU KIT (Air outlet temperature control)
Indoor unit D	AHU KIT (Return air temperature control)

Error code	Description
U41	Connection ratio A <45% or connection ratio A >135% Connection ratio A+D <45% or connection ratio A+D >135%
U42	Connection ratio B <45% or connection ratio B >105% Connection ratio B+C >35%
U43	Connection ratio C <45% or connection ratio C >105%
U44	Connection ratio D <45% or connection ratio D >115%
U48	Connection ratio A+B+C+D >135%

Connection ratio	Computing method
A	Total capacity of online indoor unit A / Total capacity of outdoor unit
B	Total capacity of online indoor unit B/ Total capacity of outdoor unit
C	Total capacity of online indoor unit C/ Total capacity of outdoor unit
D	Total capacity of online indoor unit D/ Total capacity of outdoor unit
A+D	Total capacity of online indoor unit A+D / Total capacity of outdoor unit
B+C	Total capacity of online indoor units B+C/ Total capacity of outdoor unit
A+B+C+D	Total capacity of online indoor units A+B+C+D/ Total capacity of outdoor unit

- Recover condition: Indoor/outdoor unit connection rate within allowable range.
- Reset method: Resume manually.

Possible causes

- Indoor/outdoor unit connection rate out of allowable range.

Procedure

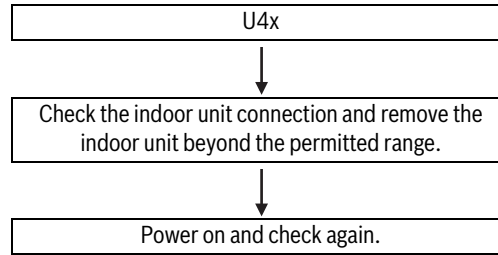

7.2.51 U51: Outdoor unit of individual series is installed in combined system

Digital display output

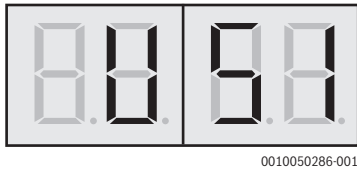

Description

- Outdoor unit of individual series is installed in combined system.
- All units stop running.

Procedure

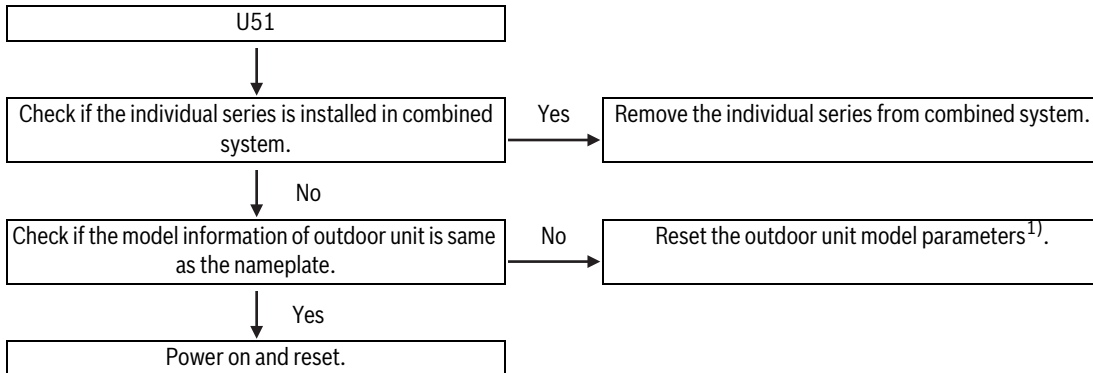

1) Use Bluetooth module or Bluetooth after-sales kit to check and reset the model parameter.

- Error code is only displayed on outdoor unit.

Trigger/recover condition

- Trigger condition: Outdoor unit of individual series is installed in combined system.
- Recover condition: Remove the individual series from combined system.
- Reset method: Resume manually.

Possible causes

- Outdoor unit of Individual Series is installed in combined system.
- Outdoor unit model is incorrectly set

7.2.52 U53: Detected different series outdoor units in the same VRF system

Digital display output

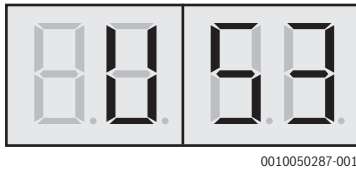

- All units stop running.
- Error code is only displayed on outdoor unit.

Trigger/recover condition

- Trigger condition: Detected different series outdoor units in the same VRF system.
- Recover condition: There is only one series of outdoor unit in combined system.
- Reset method: Resume manually.

Description

- Detected different series outdoor units in the same VRF system.

Possible causes

- Detected different series outdoor units in the same VRF system.

Procedure

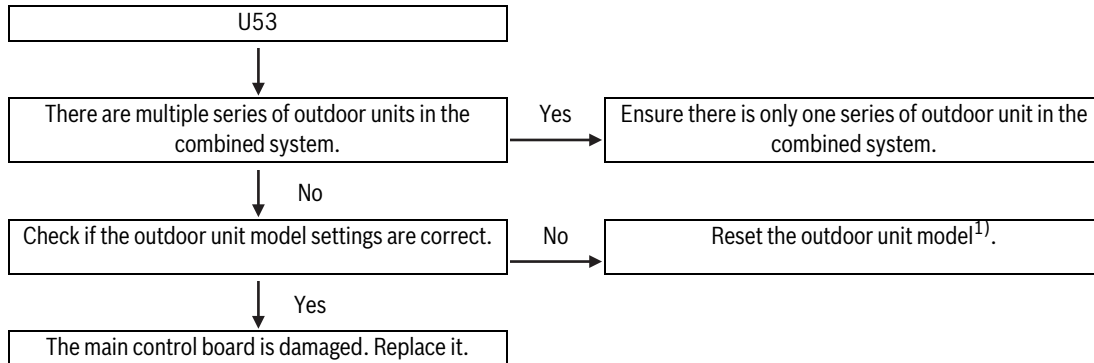

1) Use Bluetooth module or Bluetooth after-sales kit to check and reset the model parameter.

7.2.53 Error in compressor driver

7.2.54 xL1E: Hardware over-current

Digital display output

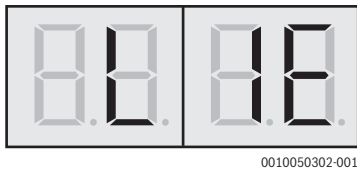

Description

- The current exceeds the OCP protection value (peak value) set by the hardware or the IPM module receives an FO signal.
- The compressor stops running after the error occurs. If the error disappears one minute later, the compressor starts again.

Trigger/recover condition

- Current reaches OCP protection value:
 - Trigger condition: Current reaches OCP protection value.
 - Recover condition: The compressor will stop after failure, and recover after one minute when the condition of failure exit is reached.
 - Reset method: The system automatically recovers one minute after the error exit condition is reached.

- Falling edge of FO signal or continuous low level is detected:
 - Trigger condition: A falling edge or continuous low level of FO signal is detected.
 - Recover condition: The FO signal becomes high level.
 - Reset method: Resume automatically one minute after the error exit condition is reached.

Possible causes

- There are impurities in the refrigerant system or the compressor suddenly freezes the cylinder, resulting in abnormal current increase and triggering OCP.
- Compressor windings short-circuit between phases, resulting in instantaneous large current triggering OCP or FO.
- The OCP is triggered when the system power supply voltage falls or is interrupted for a short time.
- The IPM module condenses, causing a short circuit between control pins.
- Liquid refrigerant back to the compressor.
- Before starts the compressor has a certain speed.
- Module board is abnormal. (IDC operational amplifier circuit, OCP comparison circuit, PWM circuit, IPM, IGBT drive power circuit) Causes control out-of-step to generate high current to trigger OCP.

Procedure

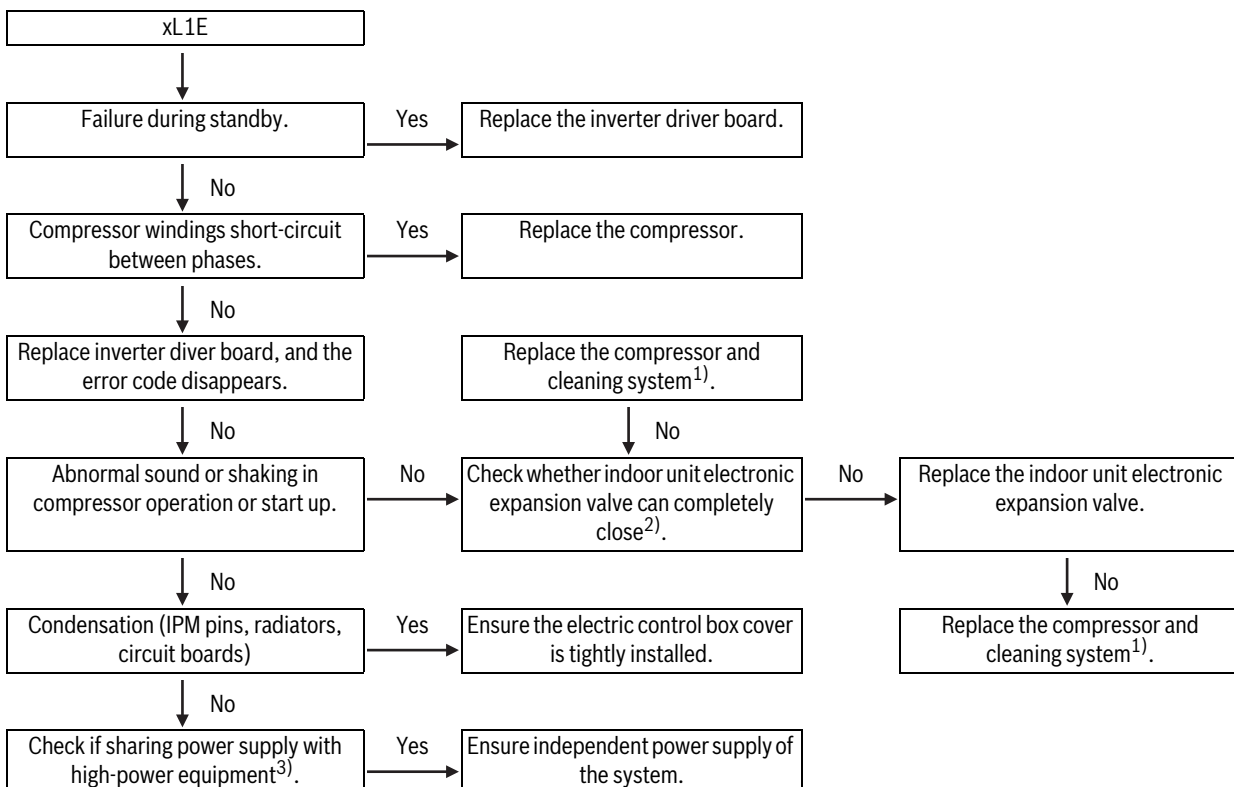

1) Close the indoor unit and check whether the temperature of the gas pipe is too low or frosted, or if the evaporator is frosted.
 2) Check if there are impurities in the refrigerant system.
 3) Voltage fluctuation occurs when high-power equipment is started.

7.2.55 xL11, xL12: Software over-current

Digital display output

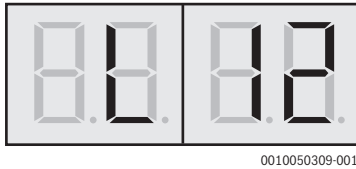
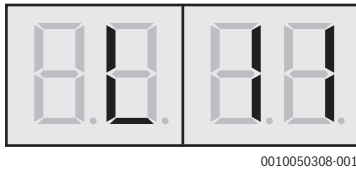

Description

- The current exceeds the OCP protection value set by the software.

Procedure

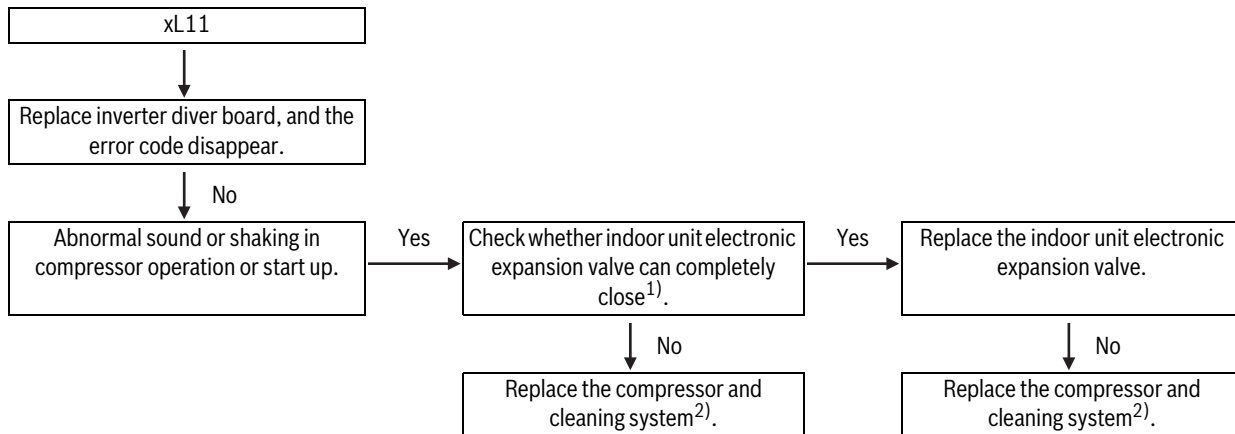

1) Close the indoor unit and check whether the temperature of the gas pipe is too low or frosted, or if the evaporator is frosted.

2) Check if there are impurities in the refrigerant system.

- The compressor will shut down when the error occurs. If the error disappears one minute later, the compressor will start again.

Trigger/recover condition

- Trigger condition:
 - xL11: The compressor current exceeds the OCP protection value set by the software in three consecutive carrier periods.
 - xL12: Software over current protection last 30s.
- Recover condition: The compressor will stop when the error occurs. If the error disappears one minute later, the compressor will start again.
- Reset method: Resume automatically after reaching exit condition of error.

Possible causes

- There are impurities in the refrigerant system or the compressor suddenly jam the cylinder.
- The IDC op-amp sampling circuit on the module is abnormal.

7.2.56 xL2E: Module over-temperature protection

Digital display output

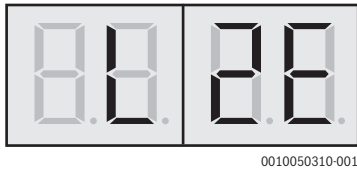

Description

- The temperature of the IPM exceeds 105 °C.
- The compressor stops when the error occurs. If the error disappears one minute later, the compressor starts again.

Trigger/recover condition

- Trigger condition: The temperature of the IPM exceeds 105 °C.
- Recover condition: The module temperature is lower than 105 °C.
- Reset method: Resume automatically.

Possible causes

- The IPM screws are not tightened, resulting in poor heat dissipation.
- The heat dissipation silicone for the IPM module is not evenly applied, resulting in poor heat dissipation.
- The refrigerant radiator is poor due to lack of refrigerant or the refrigerant radiator pipe is blocked.
- The refrigerant radiator's welding is abnormal, resulting in poor heat dissipation. The IPM temperature detection circuit is abnormal.

Procedure

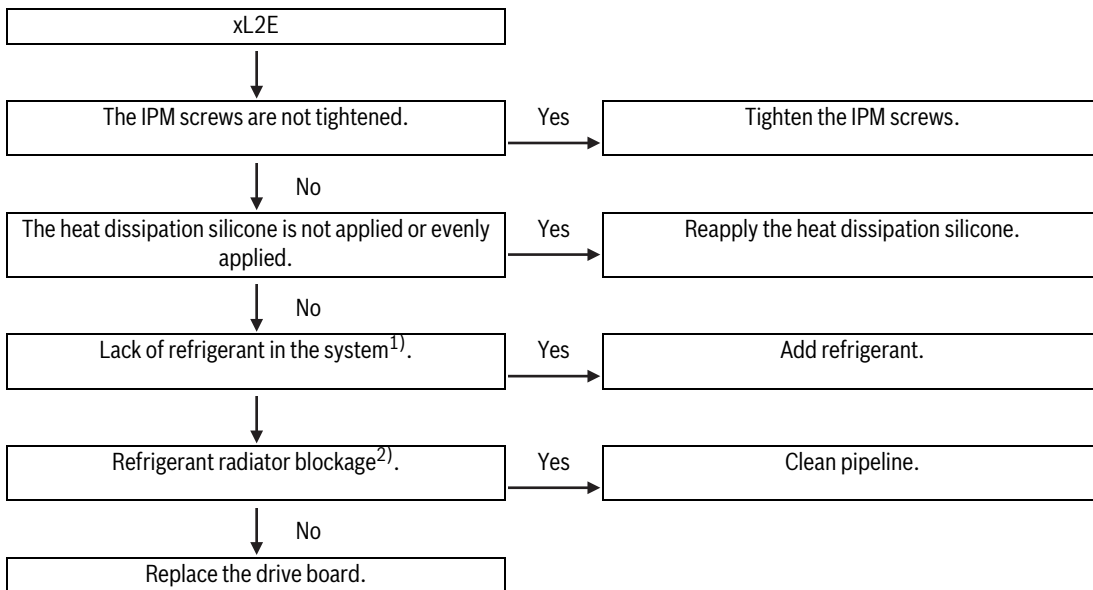

1) Less refrigerant system results in higher discharge temperature of the compressor, lower discharge and suction pressure, lower current, and frost on the gas return pipe.

2) Refer to radiator inlet and outlet temperature.

7.2.57 xL3E: The bus voltage is too low

Digital display output

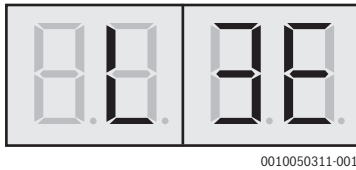

Description

- Bus voltage is lower than the low bus voltage protection threshold set by the software (350V DC).
- The compressor stops when the error occurs. If the error disappears one minute later, the compressor starts again.

Trigger/recover condition

- Trigger condition: The bus voltage is lower than the bus voltage protection threshold set by the software.
- Recover condition: The bus voltage is higher than the low bus voltage protection threshold set by the software.
- Reset method: Resume automatically after the error exit condition is reached..

Possible causes

- The input voltage is too low, resulting in the low bus voltage.
- Voltage sag or interruption, resulting in transient bus voltage is too low.
- The bus voltage detection circuit of the module is abnormal.

Procedure

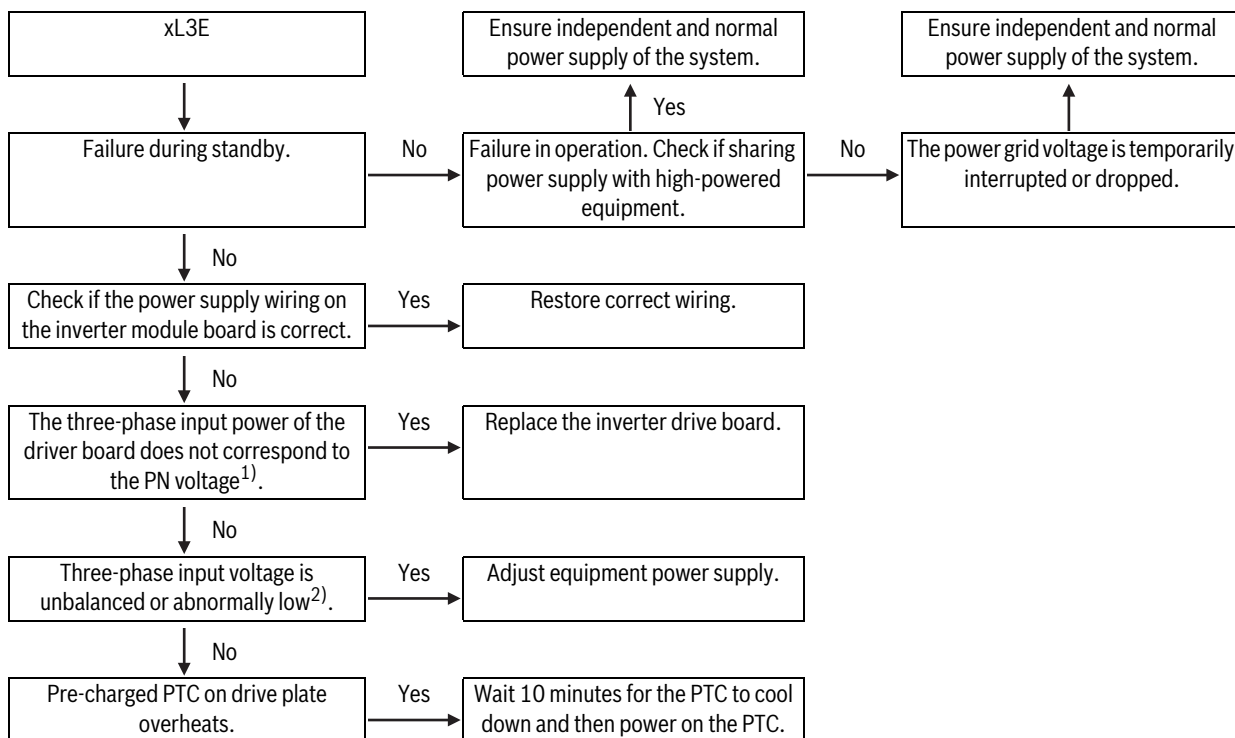

1) $V_{dc} = V_{AC} \times 1.732$, such as the corresponding PN $V_{dc} = 540V$ DC for the 380V input.

2) Line voltage below 247V AC

7.2.58 xL31: The bus voltage is excessively high

Digital display output

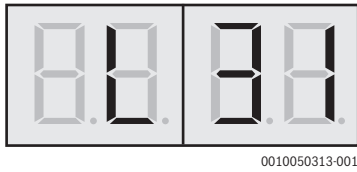

Description

- Bus voltage is higher than the low bus voltage protection threshold set by the software (350V DC).
- The compressor stops after the error occurs. If the error disappears one minute later, the compressor starts again.

Trigger/recover condition

- Trigger condition: The bus voltage is higher than the software over-voltage protection threshold.
- Recover condition: The bus voltage is lower than the over-voltage protection threshold set by the software.
- Reset method: Resume automatically after the error exit condition is reached.

Possible causes

- The input voltage is too high, resulting in the high bus voltage.
- The power grid voltage is too high.
- The module's bus voltage detection circuit is abnormal.

Procedure

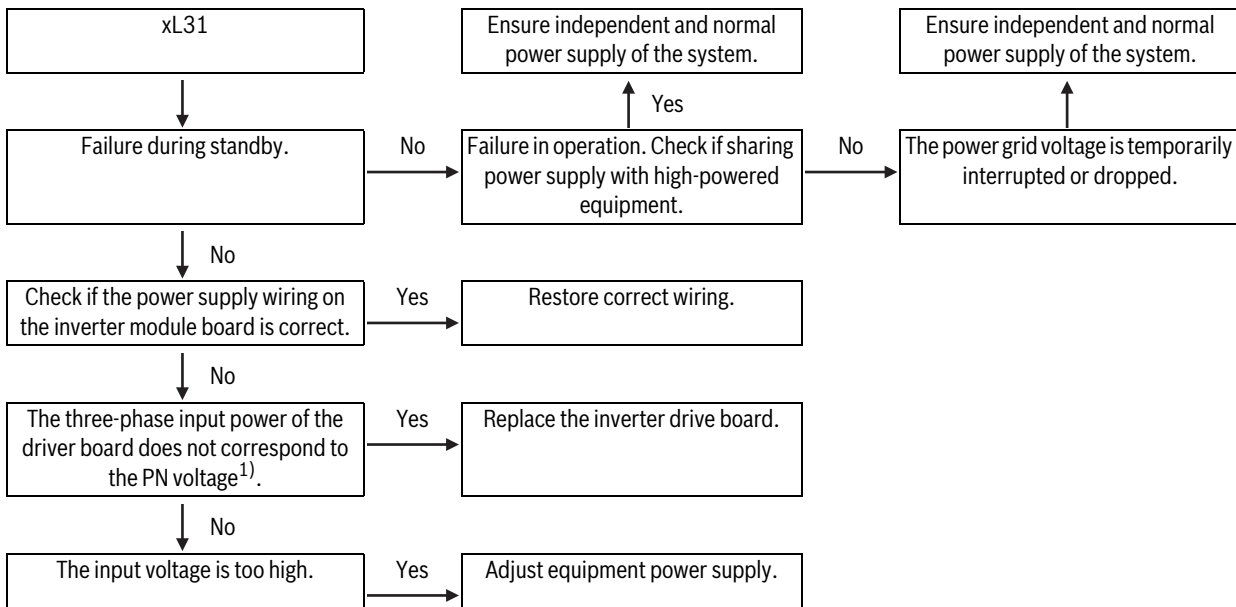

1) $V_{dc} = V_{AC} \times 1.732$, such as the corresponding PN $V_{dc} = 540V$ DC for the 380V input.

7.2.59 xL32: The bus voltage is excessively high

Digital display output

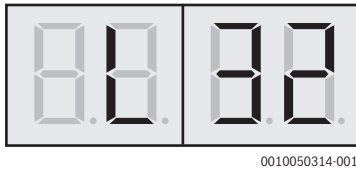

Description

- Bus voltage is higher than the high bus voltage protection threshold set by the software (820V DC).
- The compressor stops after the error occurs. If the error disappears one minute later, the compressor starts again.

Trigger/recover condition

- Trigger condition: The bus voltage is too high, higher than the high bus voltage protection threshold set by the software (820V DC).
- Recover condition: The bus voltage is lower than the high bus voltage protection threshold.
- Reset method: Resume automatically after the error exit condition is reached.

Possible causes

- The input voltage is too high, resulting in the high bus voltage.
- The power grid voltage is too high.
- The module's bus voltage detection circuit is abnormal.

Procedure

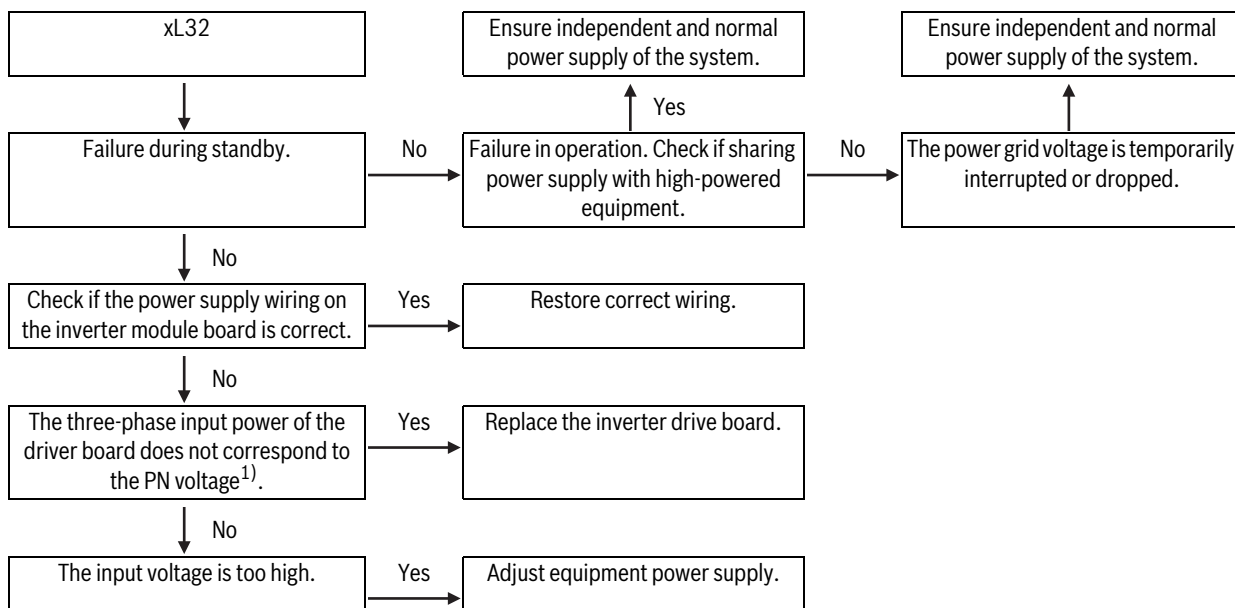

1) $V_{dc} = V_{AC} \cdot 1.732$, such as the corresponding PN $V_{dc} = 540V$ DC for the 380V input.

7.2.60 xL43: The current sampling bias is abnormal

Digital display output

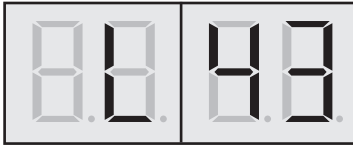

0010050316-001

Description

- Bias calibration of the current sampling circuit is in error.
- After this error occurs, the compressor cannot start. Check whether the inverter driver board is in error.

Trigger/recover condition

- Trigger condition: The AD bias value of the current sampling circuit exceeds half of the AD value range.
- Recover condition: The AD bias value of the current sampling circuit is less than half of the AD range.
- Reset method: Resume automatically.

Possible causes

- The sampling circuit of the inverter drive board is abnormal.

Procedure

- Replace the inverter drive board.

7.2.61 xL5E: Start-up failed

Digital display output

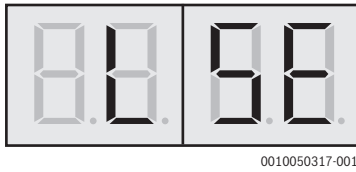

Description

- The compressor fails to start.

- The compressor stops after the error occurs. If the error disappears one minute later, the compressor starts again.

Trigger/recover condition

- Trigger condition: The compressor fails to start.
- Recover condition: If the compressor fails to start and starts again successfully, the error will be rectified.
- Reset method: Resume automatically.

Possible causes

- Discharge pressure and suction pressure of compressor is different during start up.
- The compressor is stuck.

Procedure

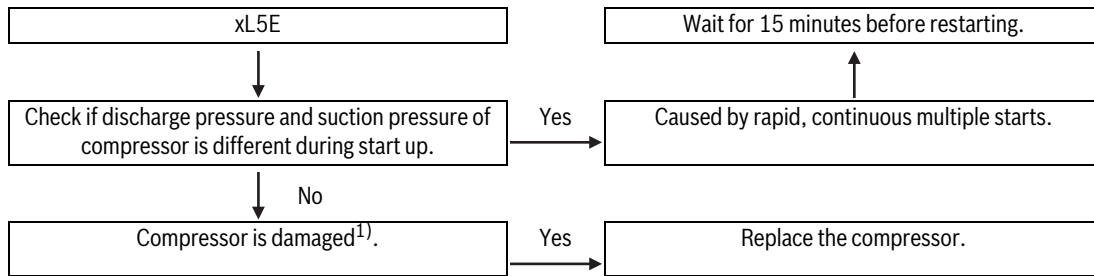

1) Abnormal sound or shaking in compressor when startup (compressor stuck cylinder, or impurities in the system).

7.2.62 xL52: Locked-rotor protection

Digital display output

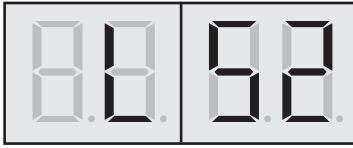

0010050319-001

Description

- The compressor is blocked.
- The compressor stops running after the error occurs. If the error disappears one minute later, the compressor starts again.

Trigger/recover condition

- Trigger condition: The compressor is blocked.
- Recover condition: The blocking error is removed.
- Reset method: Resume automatically after the error exit condition is reached.

Possible causes

- The compressor is blocked due to impurities or lack of oil in the system.

Procedure

- Match normal and faulty compressors if possible and replace the two compressors if the problem persists

7.2.63 xL6E: Motor phase loss protection

Digital display output

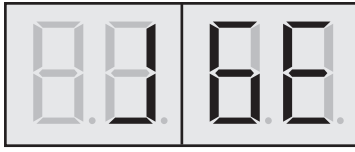

0010055144-001

Description

- Compressor motor lack of phase protection.
- The compressor stops running after the error occurs. If the error disappears one minute later, the compressor starts again.

Trigger/recover condition

- Trigger condition: The compressor cable is not connected or in poor contact.
- Recover condition: Check the cable connection of the compressor. After the cable connection is good, the error of missing phase protection is removed and recovered.
- Reset method: Resume automatically after the error exit condition is reached.

Possible causes

- The compressor cable is in poor contact or the terminal screw is not tightened.
- The inverter drive board is abnormal.

Procedure

1. Check the UVW output connection line of the inverter drive board and the UVW connection line of the compressor.
2. If possible connect the compressor with a normal inverter driver board to verify whether the original driver board is normal. If not, replace the inverter drive board.

7.2.64 Error in fan drive

7.2.65 xJ1E: Hardware over-current

Digital display output

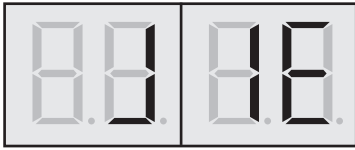

0010055143-001

Description

- The current exceeds the OCP protection value (peak value) set by the hardware or the IPM module receives an FO signal.
- The fan stops after the error occurs. If the error disappears after five seconds, the fan starts again.

Trigger/recover condition

- Current reaches OCP protection value:
 - Trigger condition: Current reaches OCP protection value.
 - Recover condition: The fan will stop after failure, and recover after five seconds when the condition of failure exit is reached.
 - Reset method: The system automatically recovers five seconds after the error exit condition is reached.
- Falling edge of FO signal or continuous low level is detected:
 - Trigger condition: A falling edge or continuous low level of FO signal is detected.
 - Recover condition: The FO signal becomes high level.
 - Reset method: Resume automatically five seconds after the error exit condition is reached.

Possible causes

- The software out of control leads to fan running stall.
- The fan is blocked or the internal coil is short-circuited.
- The IPM of inverter drive board (fan section) is damaged.
- The inverter drive board's circuits (fan section) are abnormal.

Procedure

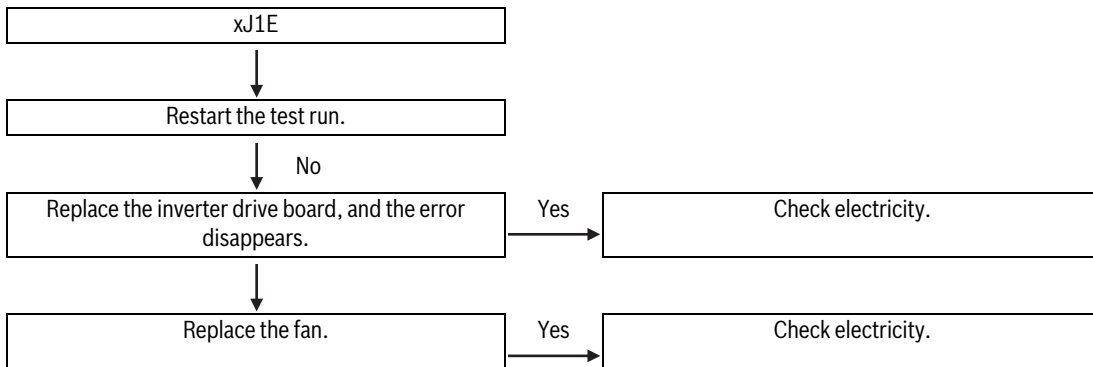

7.2.66 xJ11, xJ12: Software over-current

Digital display output

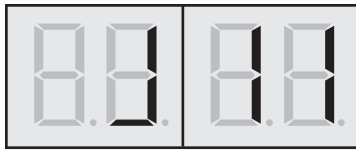

0010055141-001

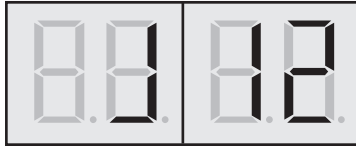

0010055142-001

Description

- The current exceeds the OCP protection value set by the software.

Procedure

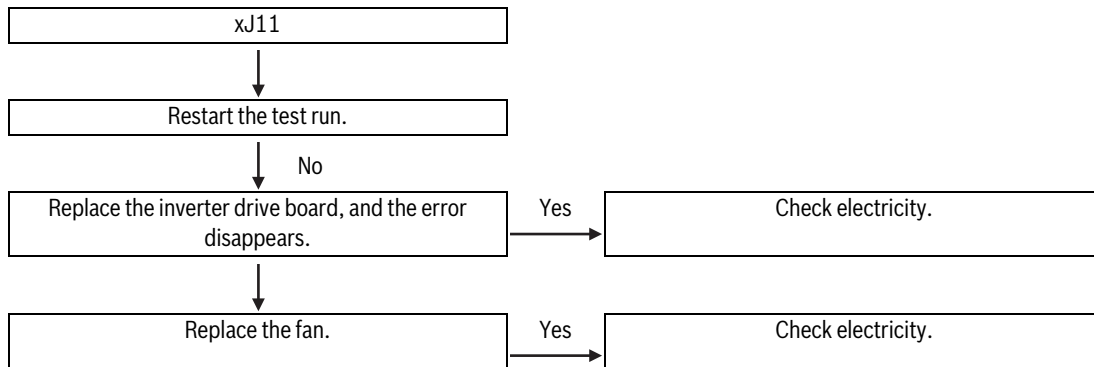

- The fan stops after the error occurs. If the error disappears after five seconds, the fan starts again.

Trigger/recover condition

- Trigger condition:
 - xJ11: The fan current exceeds the OCP protection value set by the software in three consecutive carrier periods.
 - xJ12: Software over-current protection lasts 30s.
- Recover condition: The fan will stop when the error occurs. If the error disappears five seconds later, the fan will start again.
- Reset method: Resume automatically after reaching exit condition of error.

Possible causes

- Severe fan wear.
- The software out of control leads to fan running stall.
- The driver or detection part of the inverter drive board is damaged.

7.2.67 xJ2E: Module over-temperature protection

Digital display output

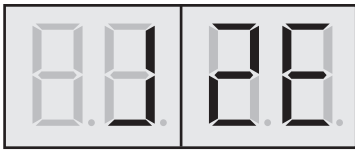

0010055140-001

Description

- The temperature of the IPM exceeds 105 °C.
- The fan stops after the error occurs. If the error disappears after five seconds, the fan starts again.

Procedure

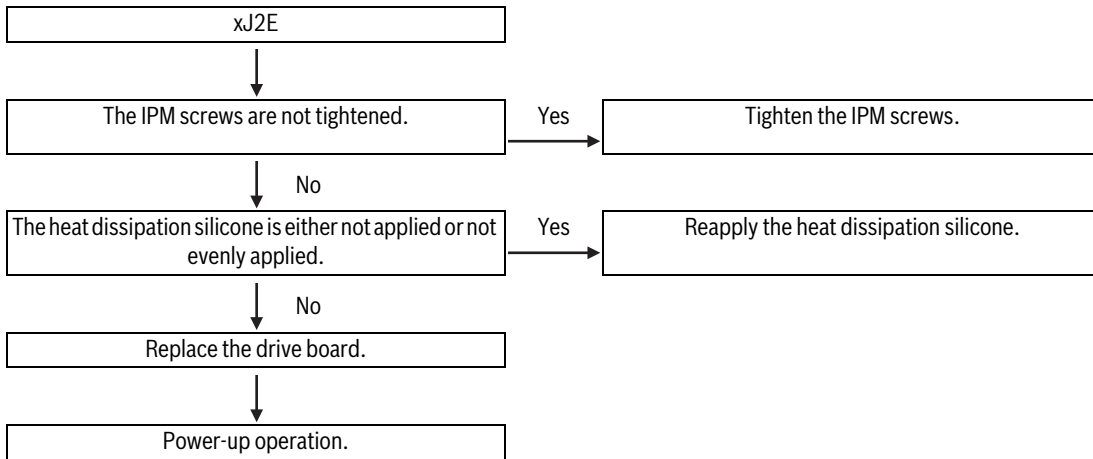

Trigger/recover condition

- Trigger condition: The temperature of the IPM exceeds 105 °C.
- Recover condition: After an error occurs, the fan is shut down. The fan will recover five seconds later when the error exit condition is reached (the module temperature is lower than 105 °C).
- Reset method: Resume automatically after reaching exit condition of error.

Possible causes

- The IPM screws are not tightened, resulting in poor heat dissipation.
- The heat dissipation silicone for the IPM module is not evenly applied, resulting in poor heat dissipation.
- The IPM temperature detection circuit is abnormal.

7.2.68 xJ3E: The bus voltage is too low

Digital display output



0010055139-001

Description

- Bus voltage is lower than the low bus voltage protection threshold set by the software (350V DC).
- The fan stops running after the error occurs. If the error disappears five seconds later, the fan starts again.

Trigger/recover condition

- Trigger condition: The bus voltage is lower than the bus voltage protection threshold set by the software.
- Recover condition: The bus voltage is higher than the low bus voltage protection threshold set by the software.
- Reset method: Resume automatically after the error exit condition is reached.

Possible causes

- The input voltage is too low, resulting in the low bus voltage.
- Voltage sag or interruption, resulting in transient bus voltage is too low.
- The bus voltage detection circuit of the module is abnormal.

Procedure

- Troubleshoot according to xL3E.

7.2.69 xJ31: The bus voltage is too high

Digital display output

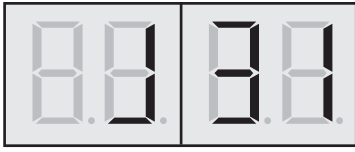

0010055138-001

Description

- Bus voltage is higher than the high bus voltage protection threshold set by the software (800V DC).
- The fan stops running after the error occurs. If the error disappears five seconds later, the fan starts again.

Trigger/recover condition

- Trigger condition: The bus voltage is higher than the software over-voltage protection threshold.
- Recover condition: The bus voltage is lower than the over-voltage protection threshold set by the software.
- Reset method: Resume automatically after the error exit condition is reached.

Possible causes

- The input voltage is too high, resulting in the high bus voltage.
- The power grid voltage is too high.
- The module's bus voltage detection circuit is abnormal.

Procedure

- Troubleshoot according to xL31.

7.2.70 xJ32: The bus voltage is excessively high**Digital display output**

0010055137-001

Description

- Bus voltage is higher than the high bus voltage protection threshold set by the software (820V DC).
- The fan stops running after the error occurs. If the error disappears five seconds later, the fan starts again.

Trigger/recover condition

- Trigger condition: Bus voltage is higher than the high bus voltage protection threshold set by the software (820V DC).
- Recover condition: The bus voltage is lower than the high bus voltage protection threshold.
- Reset method: Resume automatically after the error exit condition is reached.

Possible causes

- The input voltage is too high, resulting in the high bus voltage.
- The power grid voltage is too high.
- The module's bus voltage detection circuit is abnormal.

Procedure

- Troubleshoot according to xL32.

7.2.71 xJ43: Abnormal current sampling

Digital display output

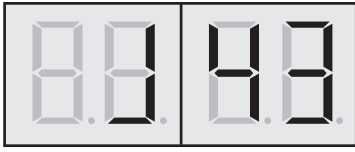

0010055136-001

Description

- Bias calibration of the current sampling circuit is in error.
- After this error occurs, the fan cannot start. Check whether the inverter driver board is in error.

Trigger/recover condition

- Trigger condition: The AD bias value of the current sampling circuit exceeds half of the AD value range.
- Recover condition: The AD bias value of the current sampling circuit is less than half of the AD range.
- Reset method: Resume automatically after the error exit condition is reached.

Possible causes

- The sampling circuit of the inverter drive board is abnormal.

Procedure

1. Replace the inverter drive board.

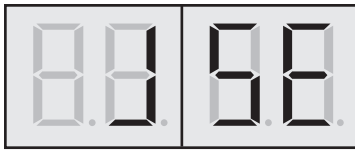
7.2.72 xJ5E: Start-up failed**Digital display output**

0010055135-001

Description

- The fan fails to be started.
- The fan stops running after the error. If the error disappears after five seconds, the fan starts again.

Trigger/recover condition

- Trigger condition: Fan start-up failure.
- Recover condition: If the fan fails to start, the fan restarts again and the error is rectified after the fan starts successfully.
- Reset method: Resume automatically after the fan starts successfully.

Possible causes

- The fan motor is stuck.
- The fan is started against the wind.
- The driver is abnormal.

Procedure

1. Check whether the motor is stuck.
2. Check whether there is a large headwind.
3. If possible, connecting a normal inverter drive board and the fan with error, check whether the fan is normal. Otherwise, replace the fan.

7.2.73 xJ52: Locked-rotor protection

Digital display output

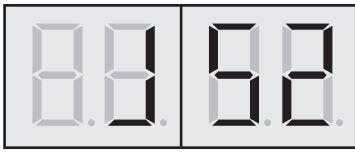

0010055134-001

Description

- The fan is blocked.

Procedure

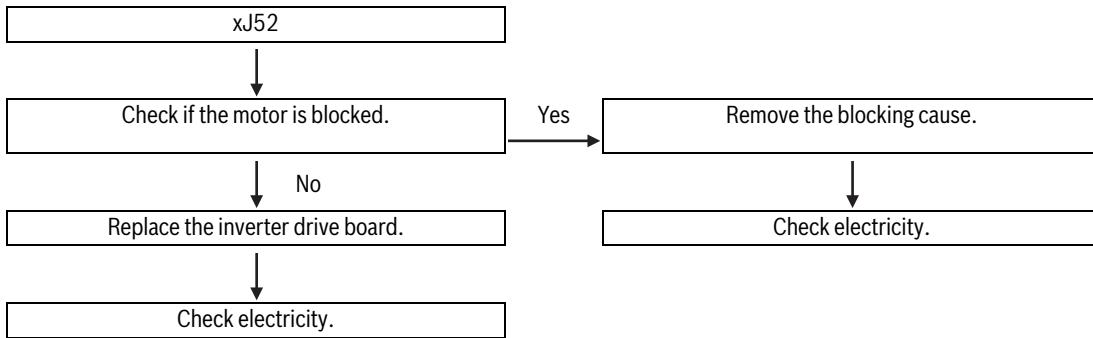

- The fan stops after the error occurs. If the error disappears after five seconds, the fan starts again.

Trigger/recover condition

- Trigger condition: The fan is blocked.
- Recover condition: The blocking error is removed.
- Reset method: Resume automatically after the error exit condition is reached.

Possible causes

- The fan shaft is stuck.

7.2.74 xJ6E: Motor lack of phase protection

Digital display output

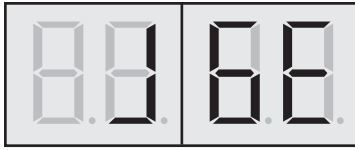

0010055133-001

Description

- The fan has phase loss protection.
- The fan stops after the error occurs. If the error disappears after five seconds, the fan starts again.

Procedure

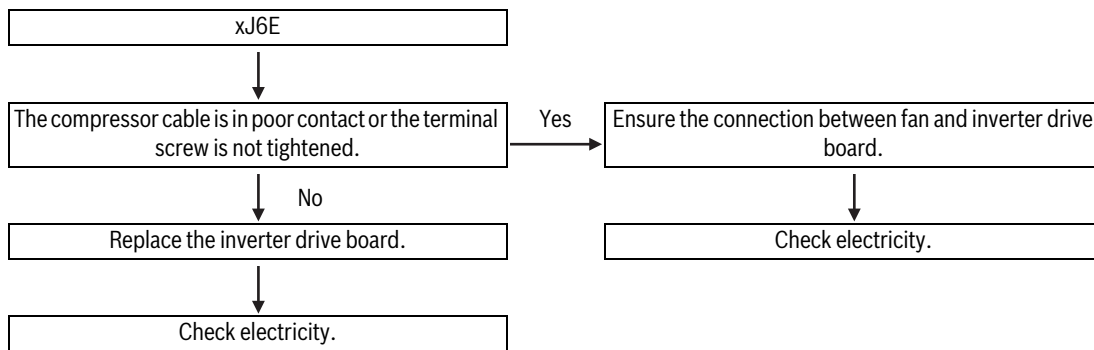

Trigger/recover condition

- Trigger condition: The fan cable is not connected or in bad contact.
- Recover condition: Check the fan wiring. After the wiring is corrected, the error of missing phase protection is removed.
- Reset method: Resume automatically after the error exit condition is reached.

Possible causes

- The compressor cable is in poor contact or the terminal screw is not tightened.
- The IPM of inverter drive board is damaged.

8 Appendix

8.1 Temperature sensor resistance characteristics

Temperature probe symbol and position		Probe type ¹⁾
T3	Heat exchanger bottom	Type A
T4	Outdoor ambient temperature	Type A
T5	Liquid pipe stop valve	Type A
T6A	Micro-channel heat exchanger inlet pipe	Type A
T6B	Micro-channel heat exchanger outlet pipe	Type A
T71	Inverter compressor A suction	Type A
T7C1	Inverter compressor A discharge	Type B
T8	Outdoor heat exchanger gas pipe	Type A
TL	Outdoor heat exchanger liquid pipe	Type A
Tg	Gas pipe stop valve	Type A
Tb	Electric control box cavity	Type A
Tr	Sampling resistance of inverter drive board	Type C
NTC	Inverter drive board	Type C

- 1) Type A is mainly used for general pipe temperature and ambient temperature detection
 Type B is mainly used for compressor discharge temperature detection
 Type C is mainly used for internal temperature detection of electronic control board

Table 48 Temperature probe symbol and position

Outdoor ambient temperature sensor and outdoor heat exchanger temperature sensor resistance characteristics

Temperature [°C]	Resistance [kΩ]		
	Type A	Type B	Type C
-20	115.3	542.7	532.2
-18	101.5	483	474.1
-16	89.59	430.5	423
-14	79.31	384.3	378
-12	70.17	343.6	338.2
-10	62.28	307.7	303.1
-8	56.37	275.9	272
-6	49.32	247.8	244.4
-4	44.00	222.8	220
-2	39.82	200.7	198.2
0	35.20	180.9	178.8
2	31.56	163.6	161.5
4	28.35	147.6	146.1
6	25.50	133.5	132.3
8	22.57	121	120
10	20.72	109.8	109
12	18.72	99.69	99.02
14	16.93	90.66	90.11
16	15.34	82.54	82.09
18	13.92	75.24	74.87
20	12.64	68.66	68.36
22	11.50	62.73	62.47
24	10.47	57.37	57.17
26	9.551	52.53	52.36
28	8.720	48.14	48.01
30	7.971	44.17	44.07
32	7.295	40.57	40.48
34	6.684	37.3	37.23
36	6.131	34.32	34.27
38	5.630	31.62	31.58

Temperature [°C]	Resistance [kΩ]		
	Type A	Type B	Type C
40	5.175	29.15	29.13
42	4.763	26.9	26.89
44	4.387	24.85	24.85
46	4.046	22.89	22.98
48	3.735	21.26	21.26
50	3.451	19.69	19.7
52	3.192	18.26	18.26
54	2.959	16.94	16.94
56	2.738	15.73	15.73
58	2.540	14.62	14.62
60	2.358	13.59	13.6
62	2.191	12.65	12.65
64	2.037	11.79	11.79
66	1.896	10.99	10.99
68	1.766	10.25	10.25
70	1.647	9.569	9.576
72	1.537	8.94	8.947
74	1.435	8.358	8.362
76	1.341	7.82	7.821
78	1.254	7.321	7.323
80	1.174	6.859	6.858
82	1.100	6.43	6.432
84	1.031	6.033	6.033
86	0.9668	5.663	5.667
88	0.9075	5.32	5.322
90	0.8525	5	5
92	0.8013	4.703	4.705
94	0.7537	4.426	4.431
96	0.7094	4.167	4.176
98	0.6682	3.927	3.938
100	0.6297	3.702	3.716
102	0.5939	3.492	3.514

Temperature [°C]	Resistance [kΩ]		
	Type A	Type B	Type C
104	0.5604	3.296	3.326
106	0.5291	3.113	3.148
108	0.4999	2.941	2.982
110	0.4726	2.781	2.826
112	0.4470	2.63	2.672
114	0.4230	2.489	2.528
116	0.4006	2.357	2.39
118	0.3796	2.233	2.256
120	0.3598	2.117	2.132
122	0.3413	2.007	2.017
124	0.3239	1.905	1.91
126	0.3075	1.808	
128	0.2922	1.717	
130	0.2777	1.632	
132	0.2641		
134	0.2513		

Table 49 Outdoor ambient temperature sensor and outdoor heat exchanger temperature sensor resistance characteristics

8.2 Normal operating parameters of refrigerant system

Under the following conditions, the operating parameters given in Tables 50 and 51 should be observed:

- The master outdoor unit can detect all the indoor units.
- The number of indoor units displayed is steady and is equal to the actual number of indoor units installed.
- All stop valves are open and all indoor unit EXVs are connected to their unit's PCB.
- If the combination ratio is 100% or less, all the indoor units are currently running. If the combination ratio is more than 100%, the

operating capacity of the indoor units is equal to the total capacity of the outdoor units.

- If the outdoor ambient temperature is high, the system is being run in cooling mode with the following settings: temperature 17 °C; fan speed high.
- If the outdoor ambient temperature is low, the system is being run in heating mode with the following settings: temperature 30 °C; fan speed high.
- The system has been running normally for more than 30 minutes.

Outdoor ambient temperature	Average discharge temperature	Average discharge superheat	Discharge pressure	Suction pressure	DC bus compressor current
[°C]	[°C]	[°C]	[MPa]	[MPa]	[A]
< 10	60-76	17-30	2.3-2.8	0.6-0.7	9-32
10 to 26	62-78	17-33	2.3-2.8	0.7-0.9	11-38
26 to 31	65-82	17-34	2.4-3.6	0.8-1.0	20-44
31 to 41	67-92	17-36	2.6-3.8	1.0-1.2	26-44
> 41	69-92	10-32	3.1-4.1	1.2-1.4	20-46

Table 50 Outdoor unit cooling mode operating parameters

Outdoor ambient temperature	Average discharge temperature	Average discharge superheat	Discharge pressure	Gas pressure bottom	DC bus compressor current
[°C]	[°C]	[°C]	[MPa]	[MPa]	[A]
< -10	56-74	17-35	1.7-2.4	0.4-1.0	14-38
-10 to 0	57-76	17-35	1.8-2.5	0.5-1.2	15-38
0 to 5	58-78	17-35	1.9-3.0	0.5-1.2	16-30
5 to 10	61-82	17-33	2.2-3.2	0.5-1.3	20-40
10 to 17	63-82	14-33	2.3-3.2	0.5-1.3	18-42
> 17	63-82	14-33	2.3-3.2	0.6-1.4	12-35

Table 51 Outdoor unit heating mode operating parameters

8.3 Cause analysis of system anomalies

Cause analysis of excessive discharge temperature

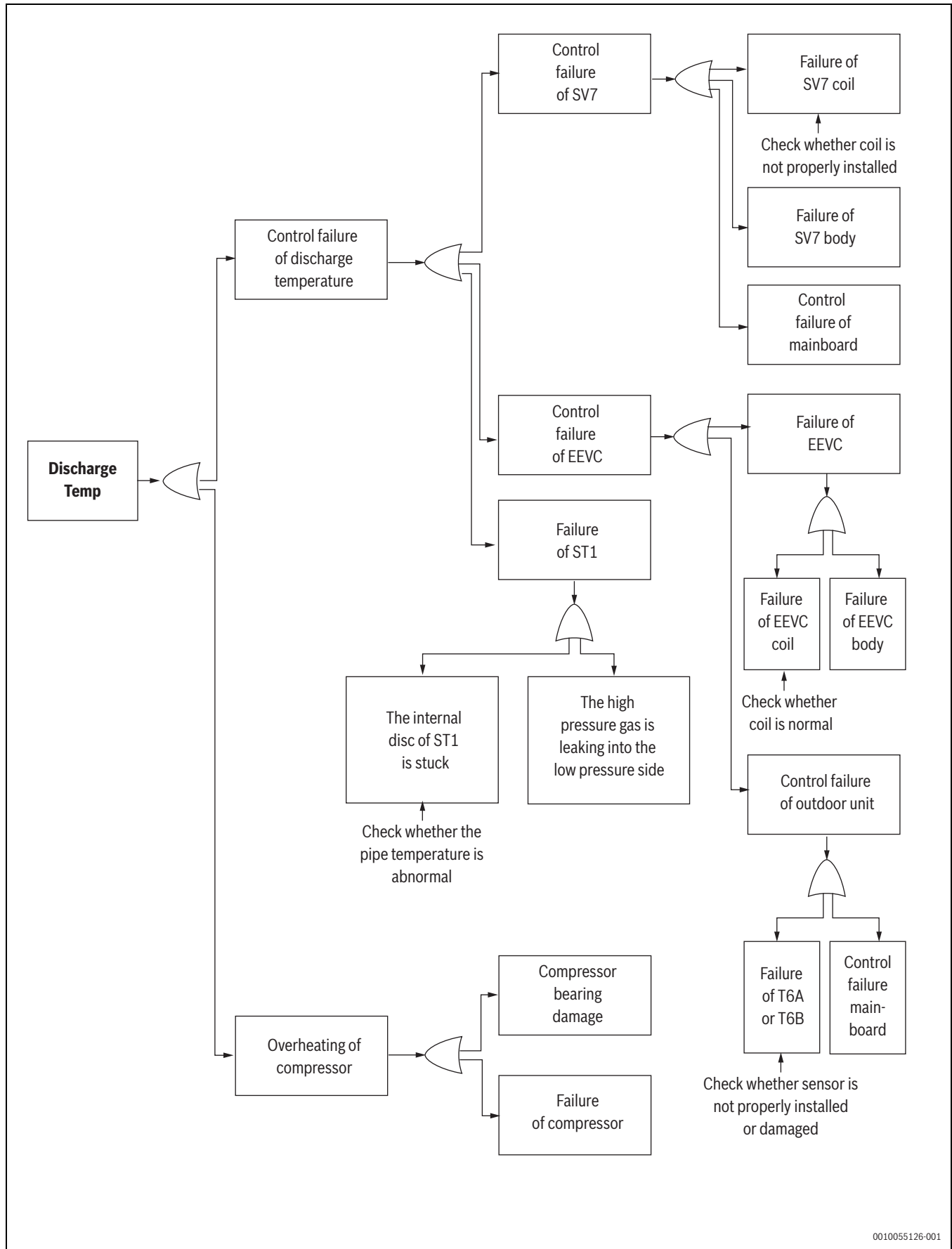

0010055126-001

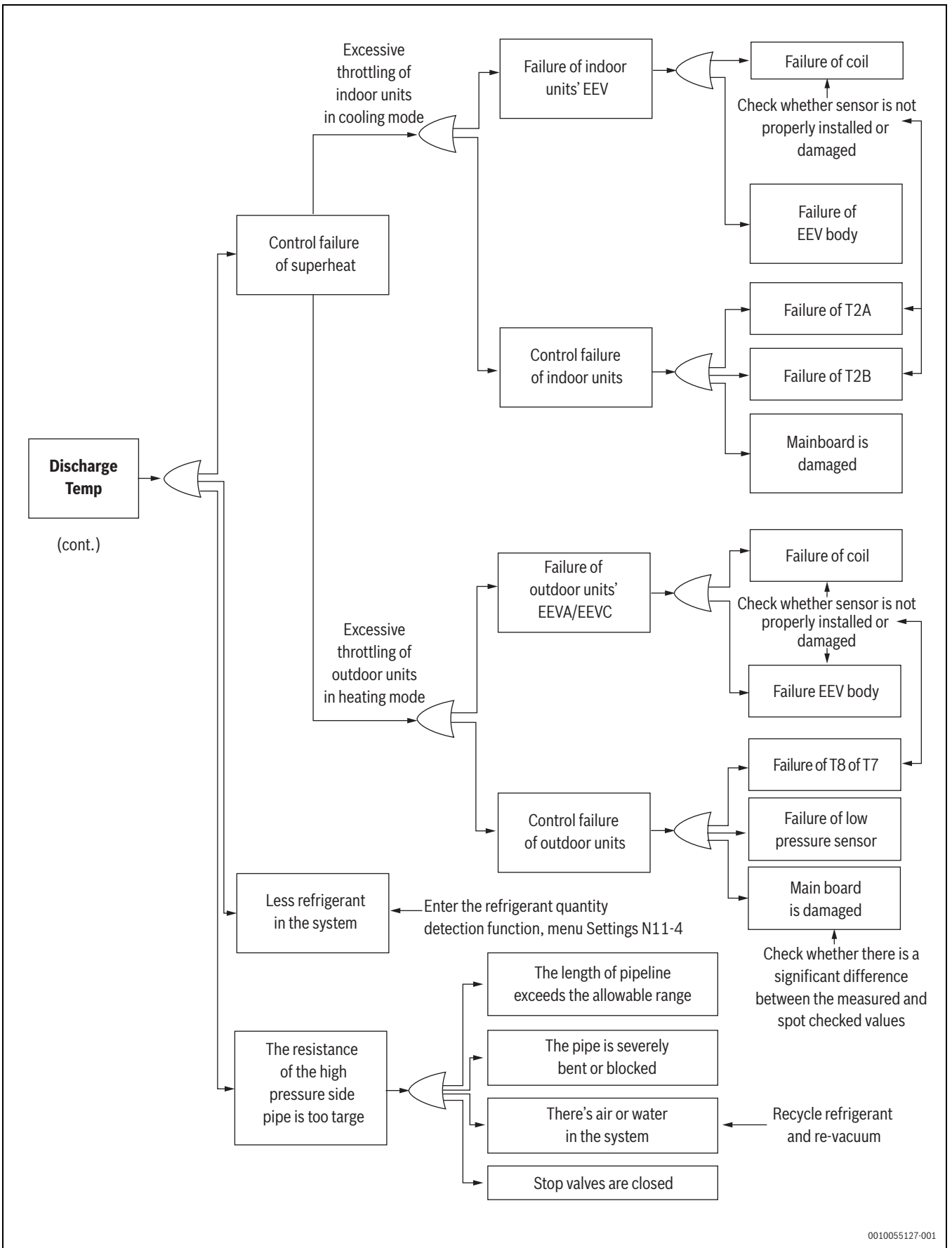

0010055127-001

Cause analysis of excessively high pressure

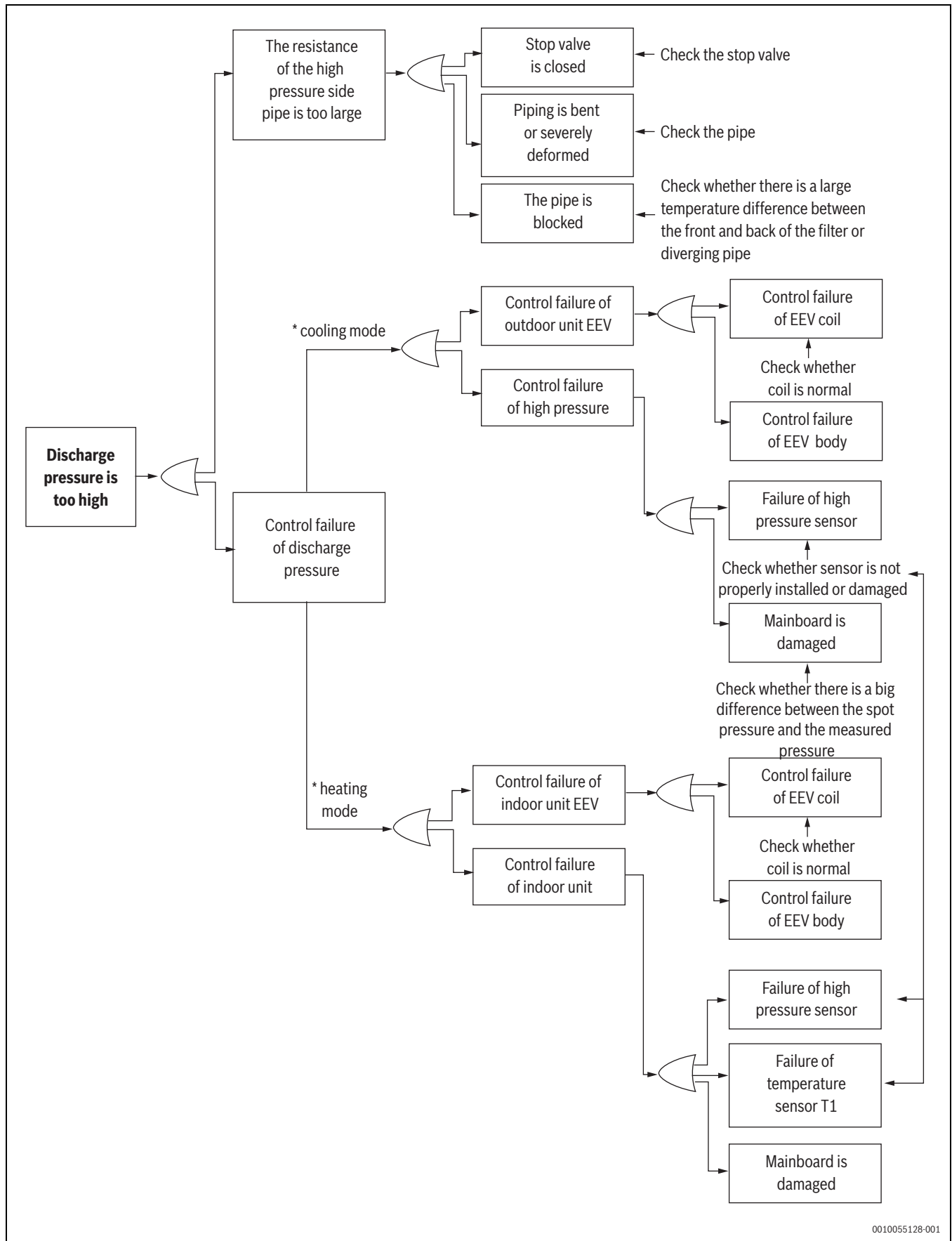

0010055128-001

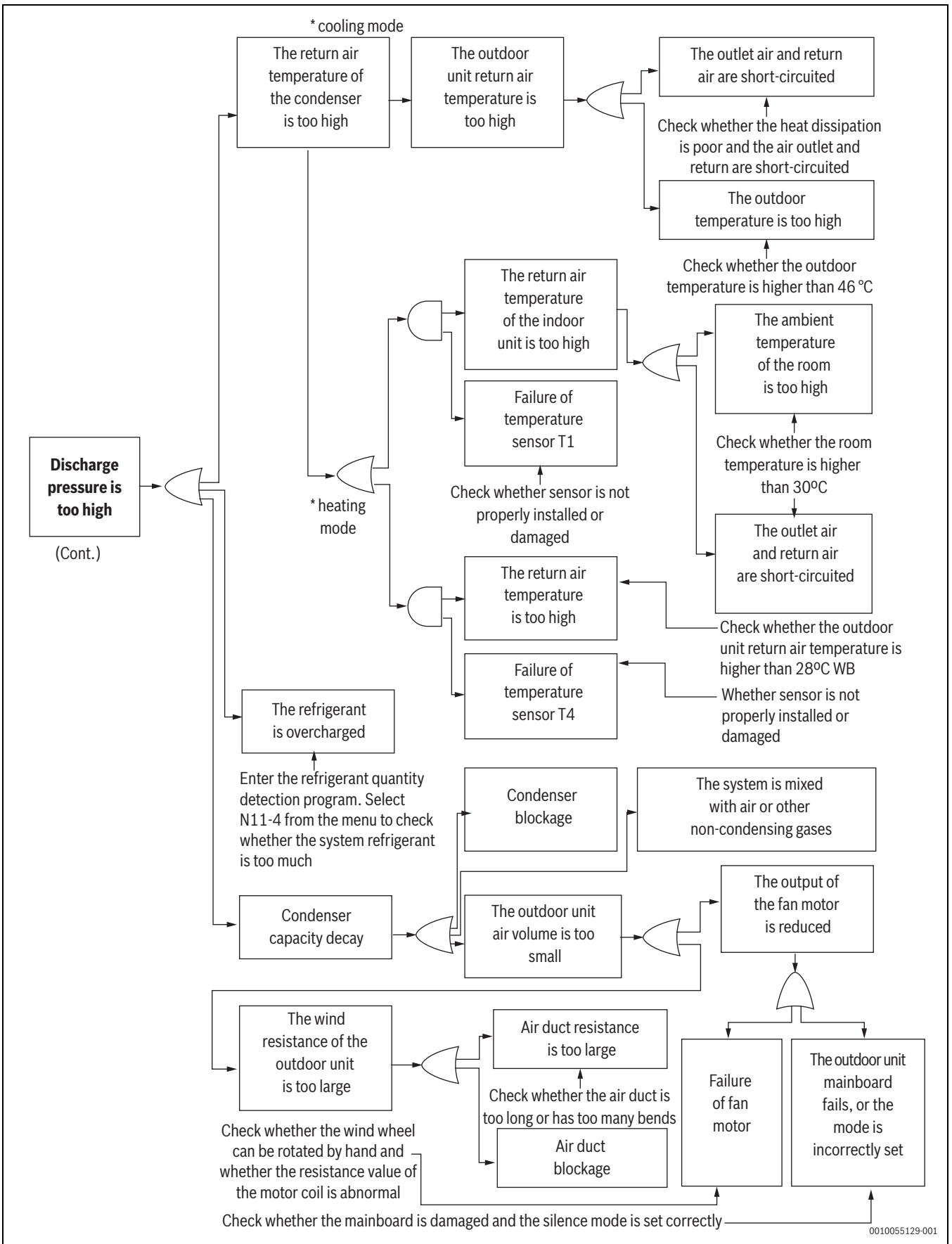

Cause analysis of excessively low pressure

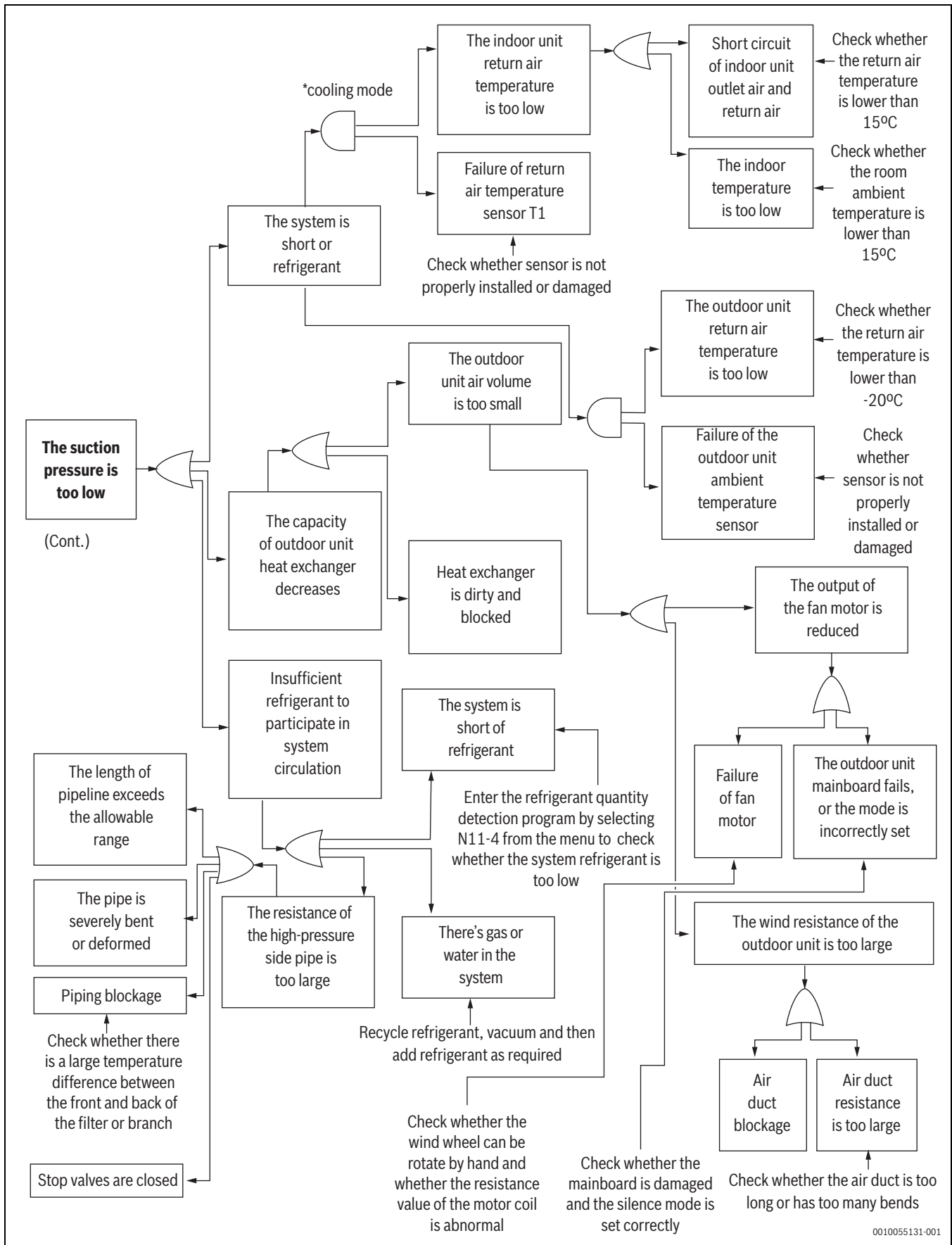

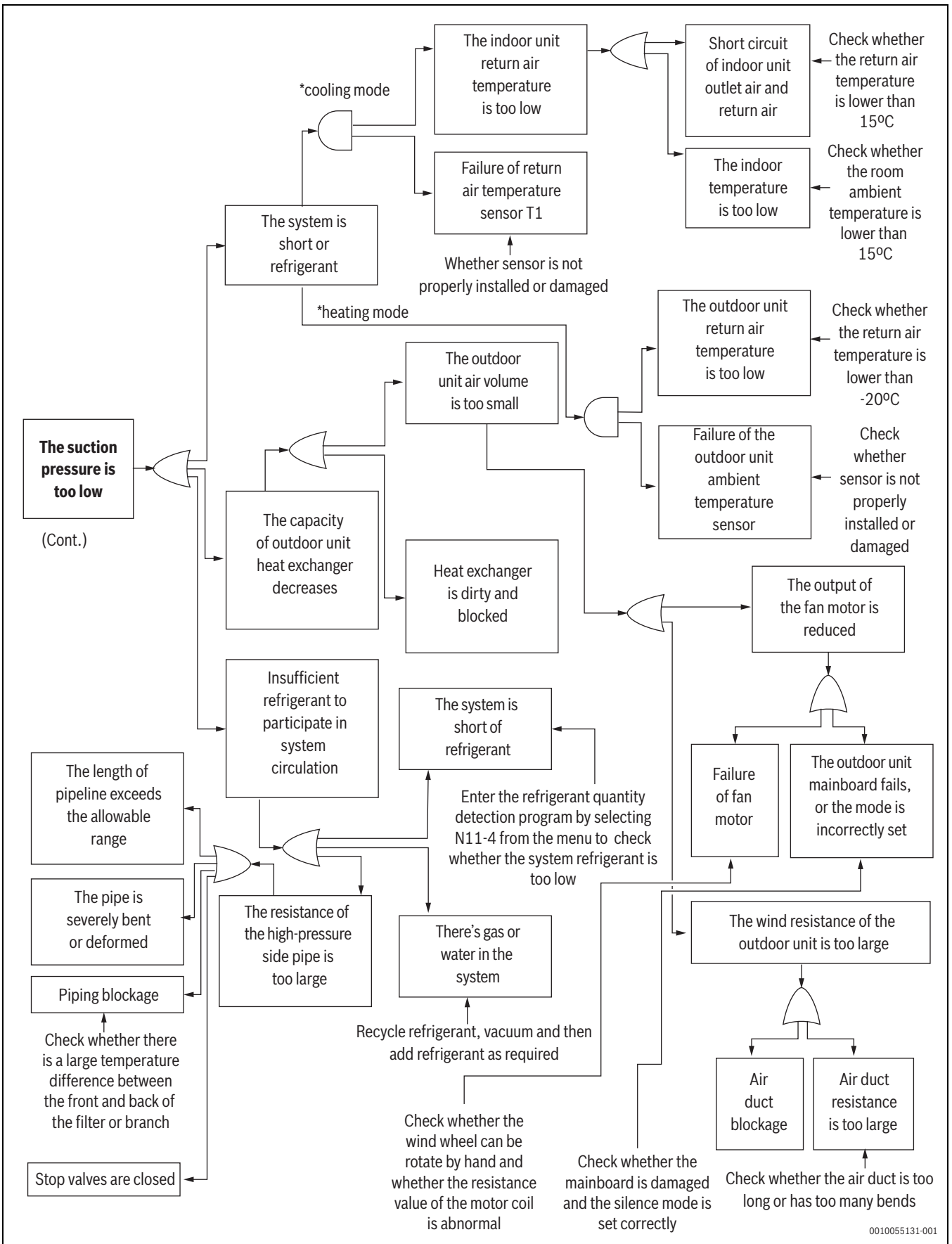

8.4 Outdoor unit main control board ports table

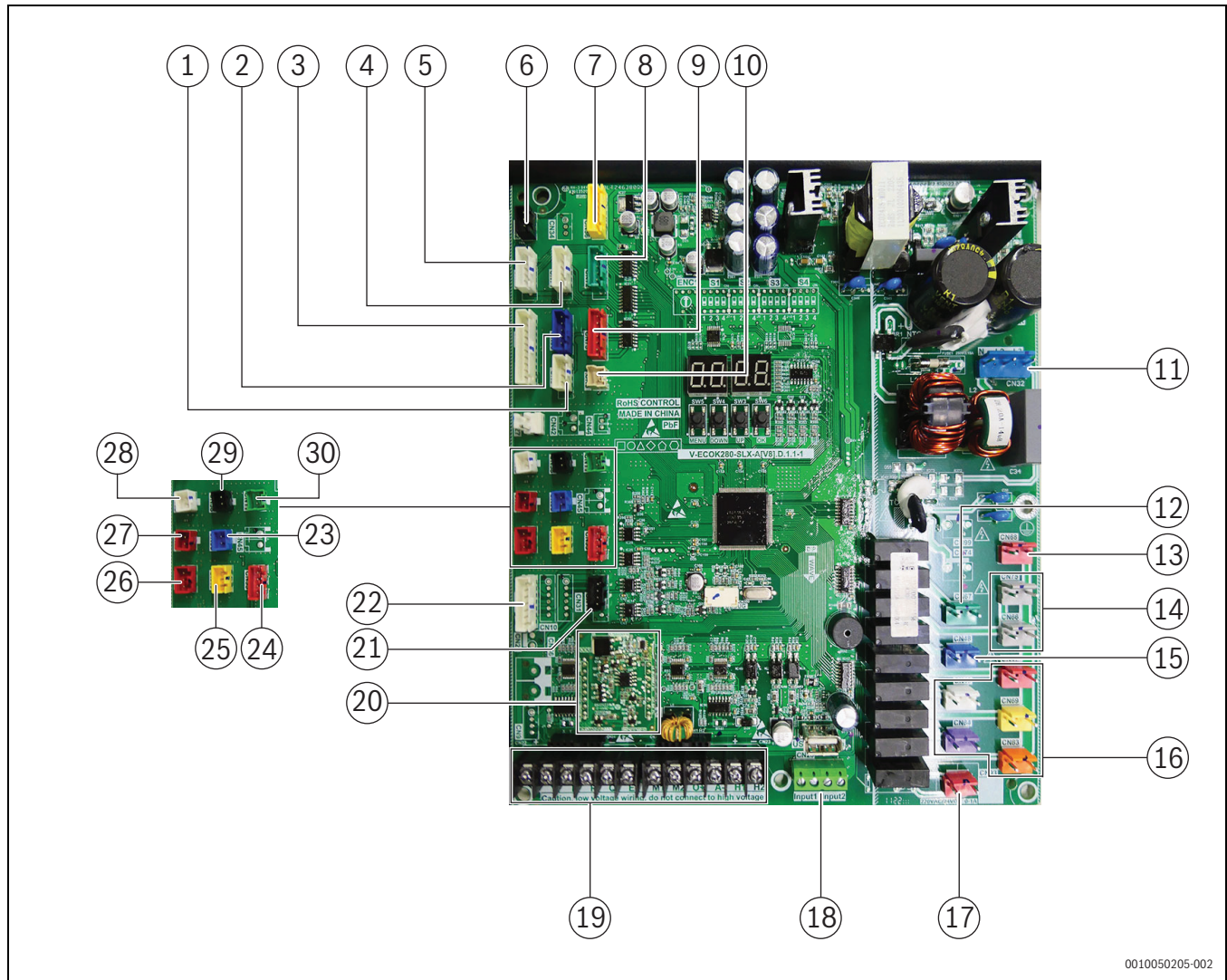

0010050205-002

Fig. 47 Outdoor unit main PCB ports

Label in Fig. 47	Port code	Content	Port voltage
1	CN8	Condenser inlet temperature sensor (T8) Main exchanger pipe temperature sensor (T3)	3.3V DC
2	CN35	Reserved	3.3V DC
3	CN4	Micro-channel heat exchanger inlet temperature sensor (T6A) Liquid pipe inlet temperature sensor (T5) Micro-channel heat exchanger outlet temperature sensor (T6B) Suction temperature sensor 1 (T71) Discharge temperature sensor 1 (T7C1)	3.3V DC
4	CN71	Reserved; EEVB drive port	12V DC
5	CN70	EEVA drive port	12V DC
6	CN82	Reserved	5V DC
7	CN36	Recirculation fan control port	3.3V DC
8	CN72	EEVC drive port	12V DC
9	CN73	EEVE drive port	12V DC
10	CN3	Condenser outlet temperature sensor (TL)	3.3V DC
11	CN32	Power input of the main board	176V AC - 264V AC
12	CN67	Reserved; Solenoid valve drive ports CN67-SV4	176V AC - 264V AC
13	CN68	Recirculation fan power	176V AC - 264V AC
14	CN75/CN66	Power supply to the compressor crankcase heater	176V AC - 264V AC
15	CN48	Four-way valve drive ports (ST1)	176V AC - 264V AC

Label in Fig. 47	Port code	Content	Port voltage
16	CN47 / CN49 / CN69 / CN84 / CN83	Solenoid valve drive ports CN47-SV6; CN49-SV5; CN69-SV7; CN8-SV8A; CN83-SV8B	176V AC - 264V AC
17	CN93	Dry contact output	0V or Open
18	CN28	Emergency stop port	0V or Open
19	CN22/CN23	Communication port	0-5V DC (varies)
20	-	SuperLink board	-
21	CN14	Communication port to data transfer module	12V DC
22	CN26	Communication port to the compressor and fan drive board	5V DC + 12V DC
23	CN30	Outdoor ambient temperature sensor (T4)	3.3V DC
24	CN33	Expanded communication port	12V DC
25	CN40	High pressure sensor	5V DC
26	CN41	Low pressure sensor	5V DC
27	CN37	Suction temperature sensor 2 (T72)	3.3V DC
28	CN16	Gas pipe temperature sensor (Tg)	3.3V DC
29	CN38	Discharge temperature sensor 2 (T7C2)	3.3V DC
30	CN11	Electric control box chamber temperature sensor (Tb)	3.3V DC

Table 52 Main PCB ports

8.5 Compressor and fan drive board ports detection

Port reference and function definition of compressor and fan drive board

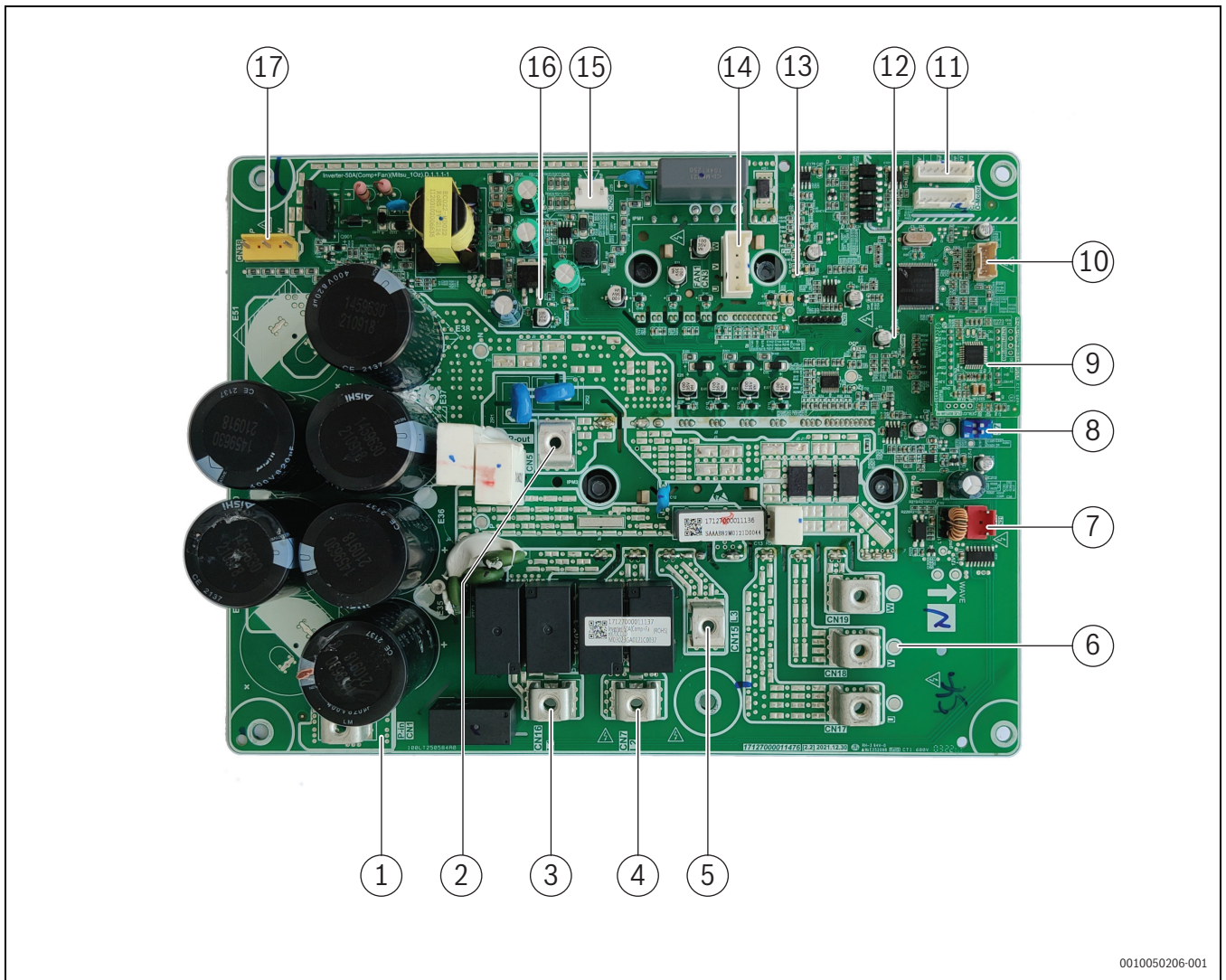
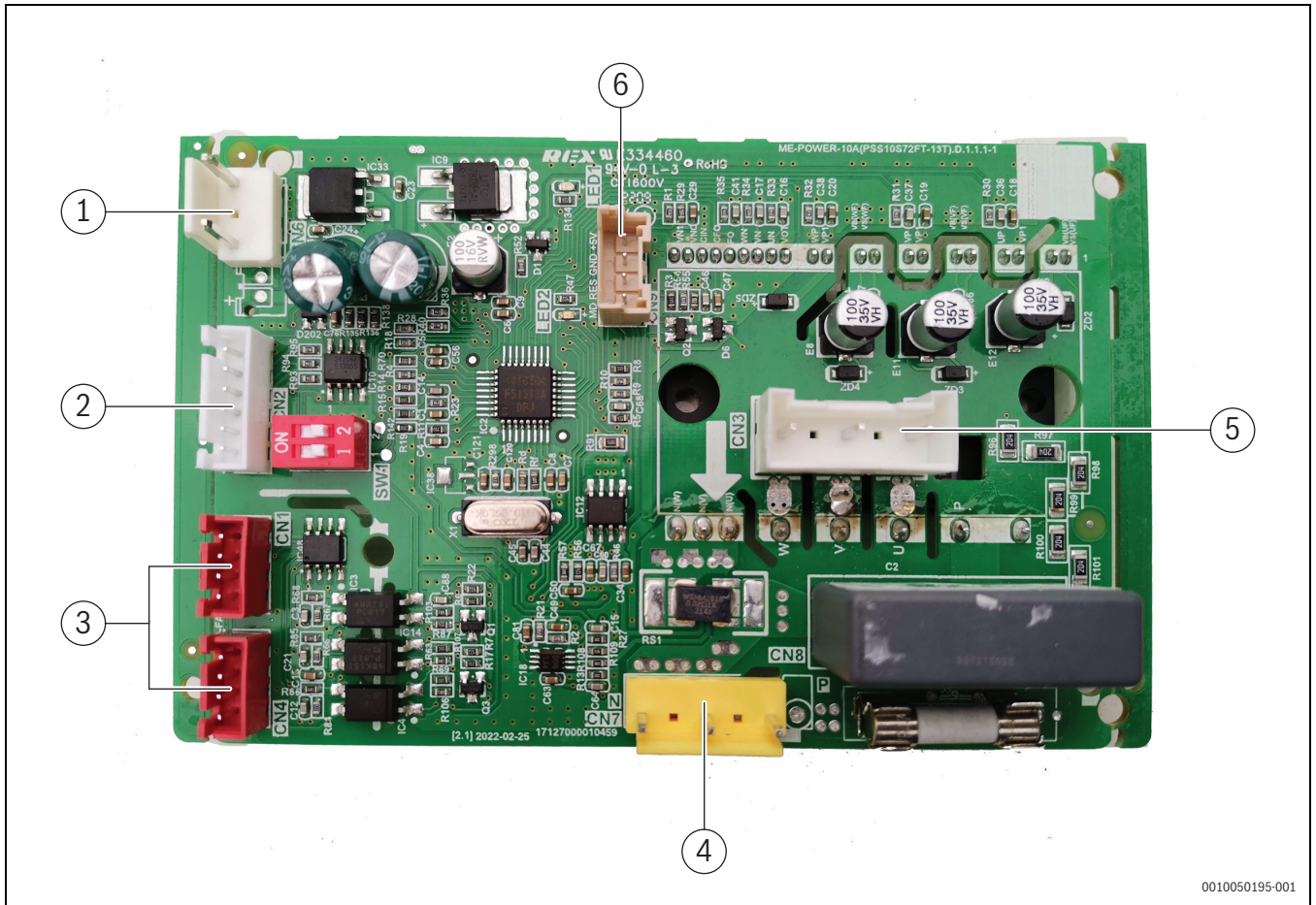

Fig. 48 Compressor and fan drive board ports

Label in Fig. 48	Port code	Feature identifier	Content	Port voltage
1	CN1	P-in	Positive pole Input terminal of the high voltage capacitors (connected to reactor)	438V DC...650V DC (Rated 540V DC)
2	CN5	P-out	Positive pole output terminal of the three-phase rectifier (connected to reactor)	438V DC...650V DC (Rated 540V DC)
3	CN16	L1	Three phase power input of L1 phase	310V DC...6460V DC (Rated 380V AC between phases)
4	CN7	L2	Three phase power input of L2 phase	310V DC...6460V DC (Rated 380V AC between phases)
5	CN15	L3	Three phase power input of L3 phase	310V DC...6460V DC (Rated 380Vac between phases)
6	CN17/18/19	U/V/W	Three phase output of the inverter, connected to the compressor	0-100%*input voltage (varying)
7	CN21	H-Pro	High pressure switch connection	Close: 0V DC, Open: 6V DC
8	S7	-	Dial switches of address setting (Compressor and fan drive module)	-
9	CN27	-	PED diagnostic module	-
10	CN25	-	Debug port	-
11	CN8/CN9	O-Motor	Communication port between main control board and inverter drive board	Ports from top to bottom are defined as follows: 5V, +, -, GND, 12V, empty, and Ry2
12	LED1	COMP	Compressor drive status indicator: red, steady on indicates running, slow blinking indicates standby, and quick blinking indicates error (see the specific error code of the nixie tube on the main board)	-
13	LED2	Fan	Fan drive status indicator: red, steady on means running, slow blinking means standby, quick blinking means error code (see the specific error code of the nixie tube on the main board)	-
14	CN3	DCFAN	Three phase output of the inverter, connected to the DC fan	0-100%*input voltage (varying)
15	CN26	-	Fan module controls power supply (Reserved)	19V
16	LED3	Power	Drive board 5V control power indicator light, green, 5V power is always on. Note that there may be residual high voltage on the drive board when the indicator is off. Use a multimeter to measure and confirm the operation	-
17	CN38	-	Power supply terminal for DC fan drive board (P,N) (Reserved)	438V DC-650V DC (Rated 540 V DC; P is positive, N is negative)

Table 53

Fan drive board



0010050195-001

Fig. 49 Fan drive board

Label in Fig. 49	Port code	Content	Port voltage
1	CN6	Fan module controls power supply (Reserved)	19V
2	CN2	EEPROM program burning port	5V
3	CN4/CN1	Communication port between main control board and fan drive board	5V
4	CN7	Power supply terminal for DC fan drive board (P,N) from main control board	Rated voltage 540V DC P(+), N(-)
5	CN3	Output power supply for fan motor	46...460V AC
6	CN9	Main program burning port	-

Table 54

Inverter drive board measurement guidelines

Please give priority to the following things before testing inverter drive board:

1. Cut off the power supply.
2. To avoid electric shock from capacitor discharge, power off for 10 minutes and wait for capacitor discharge before operation.
3. Remove all wiring on the inverter drive board.

Tools: multimeter (measurable secondary pipe)

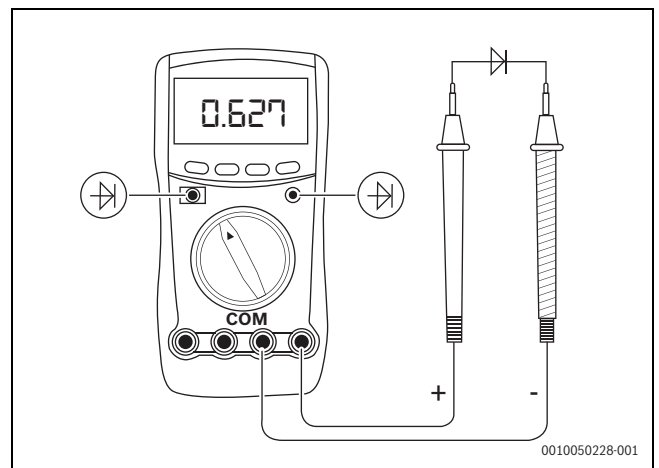

0010050228-001

The following measurements are for reference:

Number	Test point		Normal decision value	Notes
	+ (Red)	- (Black)		
1	U	P-in	0.3-0.7V	0 or + ∞ is abnormal
2	V	P-in		
3	W	P-in		
4	N	U		
5	N	V		
6	N	W		

Table 55 Inverter circuit measurement

Number	Test point		Normal decision value	Notes
	+ (Red)	- (Black)		
1	L1'	P-out	0.3-0.7V	0 or + ∞ is abnormal
2	L2'	P-out		
3	L3'	P-out		
4	N	L1'		
5	N	L2'		
6	N	L3'		

Table 56 Inverter circuit measurement

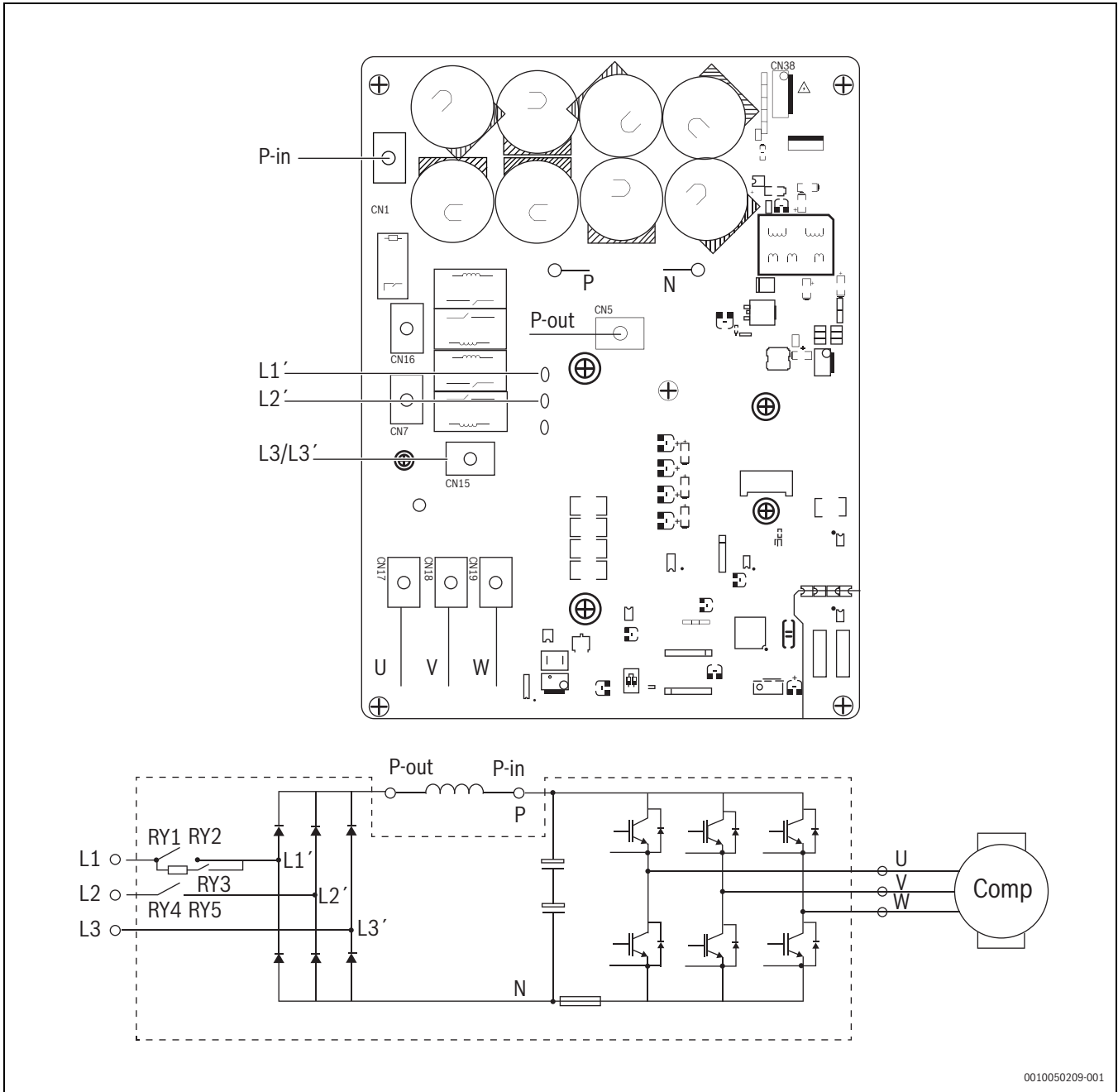

Fig. 50 Schematic diagram of the measuring points of the inverter drive board

0010050209-001

8.6 Pressure sensor detection appendix

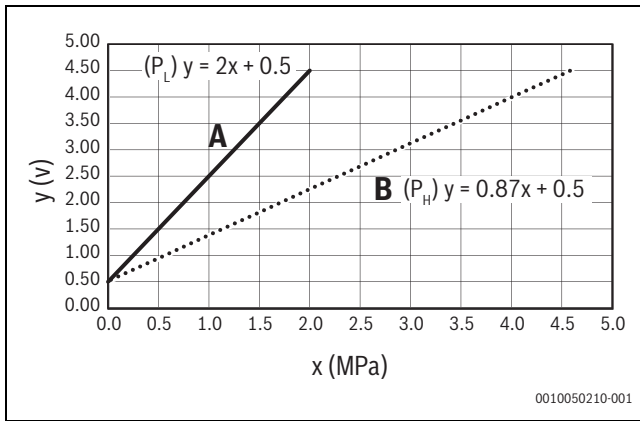

Fig. 51 Compressor and fan drive board ports detection

- A Low pressure sensor PL
- B High pressure sensor PL
- y Output voltage (V)
- x Pressure (MPa)
- PH $V_{out} (H) = 0.87 \times PH + 0.5$
- PL $V_{out} (L) = 2 \times PL + 0.5$

8.7 Refrigerant volume diagnosis

When running the refrigerant quantity detection program, the machine calculates the system refrigerant quantity according to the following information, and gives hints according to the results:

- the ambient temperature
- condensing temperature and evaporation temperature
- heat exchanger inlet and outlet temperature
- other parameters

The detection results of the system with AF indoor units may have a large deviation. It is recommended to perform the refrigerant quantity diagnostic test when the system is all AF2 indoor units and the communication protocol is AF2 communication. The following operating ranges must be met:

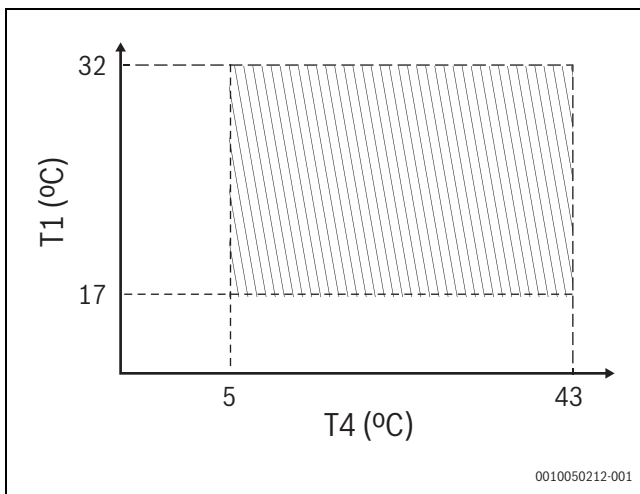

Fig. 53 Refrigerant quantity detection operating range

- T1 (°C) average indoor temperature
- T4 (°C) ambient temperature

The setting parameters are shown in the following table.



Default settings are **highlighted**.

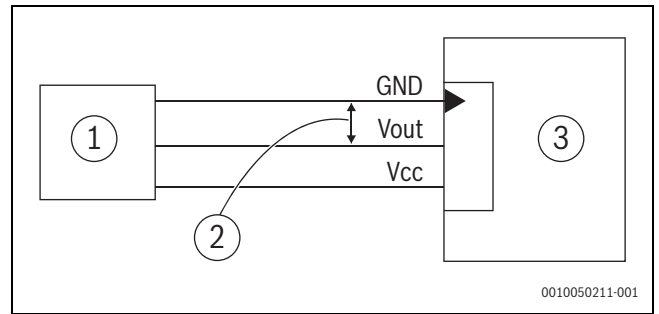

Fig. 52 Schematic diagram of measurement

- [1] Pressure sensor
- [2] Measure the DC voltage between two wires
- [3] Mainboard

Menu		Warning threshold	Excessive	Insufficient
NB	1 ¹⁾	0 – 10% 1 – 15% 2 – 20% 3 – 25% 4 – 30% 5 – 35% 6 – 40%	d33	d35
	2 ²⁾	0 – 30% 1 – 35% 2 – 40% 3 – 45% 4 – 50% 5 – 55% 6 – 60%	d32	d36

- 1) Menu NB1 sets the warning threshold X of excessive or insufficient refrigerant
- 2) Menu NB2 sets the warning threshold X of significantly excessive or significantly insufficient refrigerant.

Table 57 Refrigerant quantity warning values

Procedure

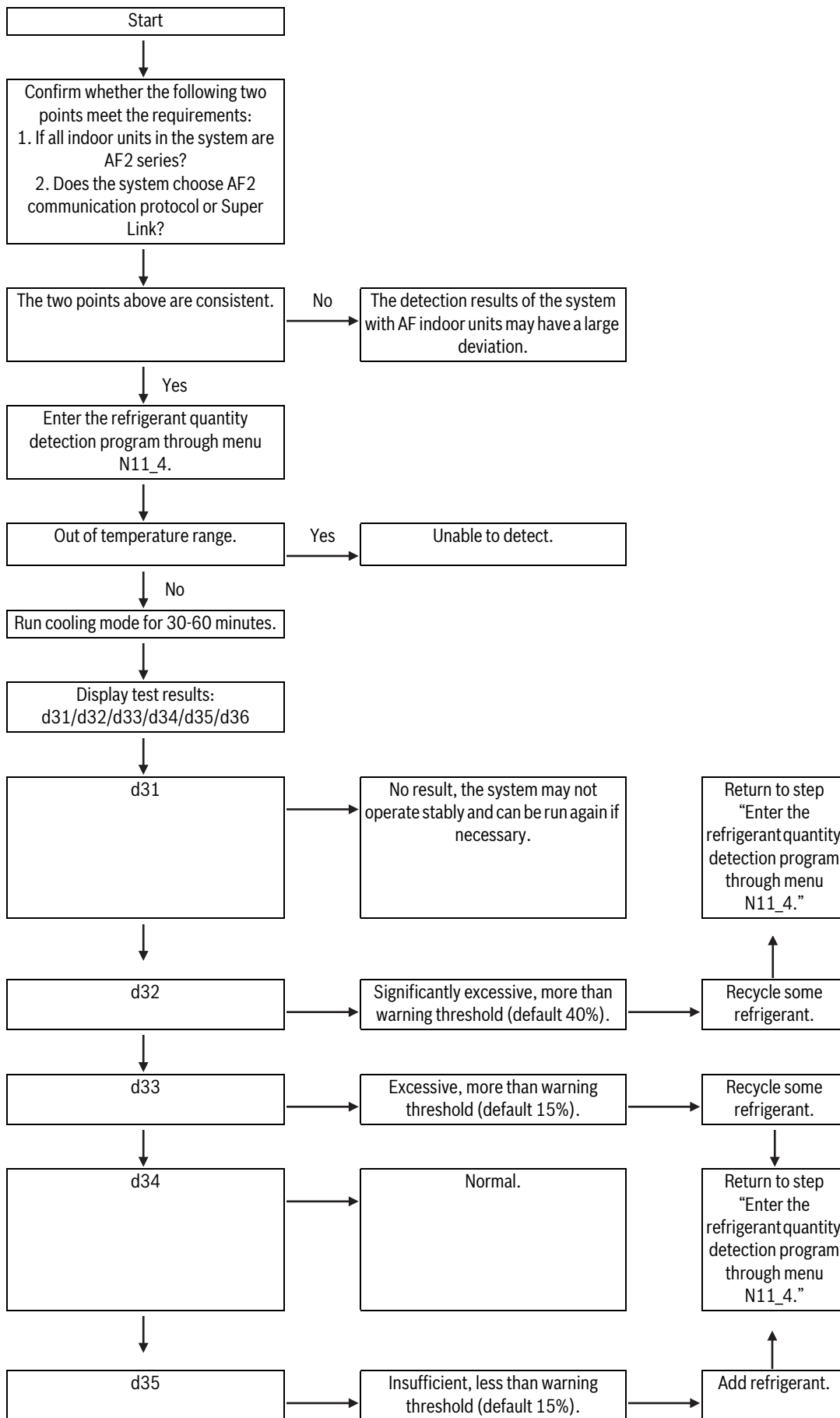

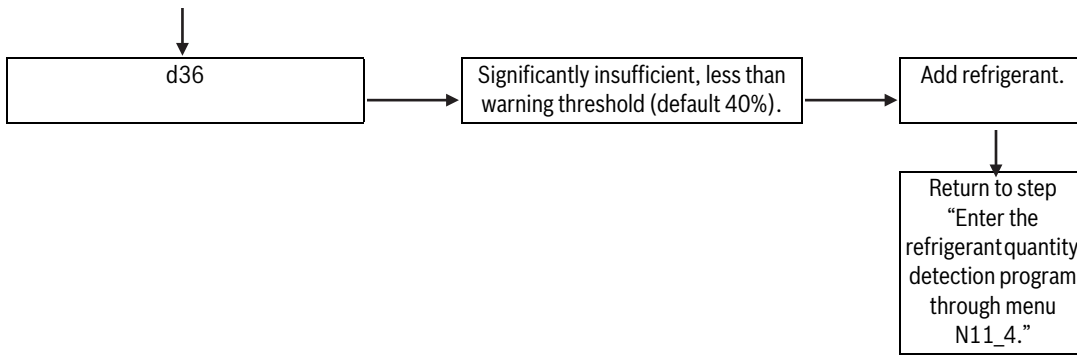

8.8 Oil volume table

kW	Oil model	Compressor A (Y1)	Compressor B (Y2)	Additional adding oil volume	Total oil	Total oil
25	FV68H	1.1L		5L	5L+1.1L	6.1L
28	FV68H	1.1L		5L	5L+1.1L	6.1L
33	FV68H	1.1L		5L	5L+1.1L	6.1L
40	FV68H	1.1L		6L	6L+1.1L	7.1L
45	FV68H	1.1L		6L	6L+1.1L	7.1L
50	FV68H	1.1L		6L	6L+1.1L	7.1L
56	FV68H	1.1L		6L	6L+1.1L	7.1L
62	FV68H	1.1L		6L	6L+1.1L	7.1L
67	FV68H	1.1L		6L	6L+1.1L	7.1L
73	FV68H	1.1L	1.1L	8L	8L+1.1L+1.1L	10.2L
79	FV68H	1.1L	1.1L	9L	9L+1.1L+1.1L	11.2L
85	FV68H	1.1L	1.1L	9L	9L+1.1L+1.1L	11.2L
90	FV68H	1.1L	1.1L	9L	9L+1.1L+1.1L	11.2L

Table 58 Oil volume table

- The gas-liquid separator and pipe do not need to be replaced if only the compressor needs to be replaced. Calculate how much oil was pulled out (for ex: X), and add X-Y1-Y2 (for 85kW, Y1 is 1.1L and Y2 is 1.1L).
- If all the compressors need to be replaced, as well as the gas-liquid separator, then the additional adding oil volume must be added as per the table above.
- Add the additional oil to the inlet of the gas-liquid separator, not directly to the compressor.

Bosch Thermotechnik GmbH
Sophienstrasse 30-32
35576 Wetzlar, Germany

www.bosch-industrial.com

